



1168A and 1169A InfiniiMax Differential and Single-ended Probes

User's Guide

Notices

© Agilent Technologies, Inc. 2011

No part of this manual may be reproduced in any form or by any means (including electronic storage and retrieval or translation into a foreign language) without prior agreement and written consent from Agilent Technologies, Inc. as governed by United States and international copyright laws.

Manual Part Number

01169-97012

Edition

Sixth edition, May 2011

Agilent Technologies, Inc.
1900 Garden of the Gods Road
Colorado Springs, CO 80907 USA

Warranty

The material contained in this document is provided “as is,” and is subject to being changed, without notice, in future editions. Further, to the maximum extent permitted by applicable law, Agilent disclaims all warranties, either express or implied, with regard to this manual and any information contained herein, including but not limited to the implied warranties of merchantability and fitness for a particular purpose. Agilent shall not be liable for errors or for incidental or consequential damages in connection with the furnishing, use, or performance of this document or of any information contained herein. Should Agilent and the user have a separate written agreement with warranty terms covering the material in this document that conflict with these terms, the warranty terms in the separate agreement shall control.

Technology Licenses

The hardware and/or software described in this document are furnished under a license and may be used or copied only in accordance with the terms of such license.

Restricted Rights Legend

If software is for use in the performance of a U.S. Government prime contract or subcontract, Software is delivered and licensed as “Commercial computer software” as defined in DFAR 252.227-7014 (June 1995), or as a “commercial item” as defined in

FAR 2.101(a) or as “Restricted computer software” as defined in FAR 52.227-19 (June 1987) or any equivalent agency regulation or contract clause. Use, duplication or disclosure of Software is subject to Agilent Technologies’ standard commercial license terms, and non-DOD Departments and Agencies of the U.S. Government will receive no greater than Restricted Rights as defined in FAR 52.227-19(c)(1-2) (June 1987). U.S. Government users will receive no greater than Limited Rights as defined in FAR 52.227-14 (June 1987) or DFAR 252.227-7015 (b)(2) (November 1995), as applicable in any technical data.

Safety Notices

A **CAUTION** notice denotes a hazard. It calls attention to an operating procedure, practice, or the like that, if not correctly performed or adhered to, could result in damage to the product or loss of important data. Do not proceed beyond a **CAUTION** notice until the indicated conditions are fully understood and met.

A **WARNING** notice denotes a hazard. It calls attention to an operating procedure, practice, or the like that, if not correctly performed or adhered to, could result in personal injury or death. Do not proceed beyond a **WARNING** notice until the indicated conditions are fully understood and met.

User's Guide

Publication Number 01169-97012
May 2011

For Safety and Regulatory information, see the pages at the back of this book.

© Copyright Agilent Technologies 2004-2011
All Rights Reserved.

1168A and 1169A InfiniiMax Differential and Single-ended Probes

In This Book

This book provides user and service documentation for the Agilent Technologies 1168A and 1169A differential and single-ended probes. It is divided into two chapters.

Chapter 1 provides an overview of the recommended configurations and capacitance values of the probe; shows you how to use the convenience accessories with the probe; and provides the frequency, impedance, and time domain response for the recommended configurations of the probe.

Chapter 2 provides service and performance verification information for the probe.

At the back of the book you will find Safety information and Regulatory information.

Contents

1 General Information

N5381A 12 GHz Solder-in Differential Probe Head	1-3
N5382A 12 GHz Differential Browser Probe Head	1-4
N5380A SMA Probe Head	1-5
Related Product - N5380-64701 SMA Head Support	1-6
N5425A ZIF Probe Head	1-7
Related Product - N5451A Long Wire ZIF Probe Tip	1-8
Related Product - N2884A Fine Wire ZIF Probe Tip	1-9
Related Product - N2887A / N2888A Soft Touch Probe Heads	1-10
E2669A Differential Connectivity Kit	1-11
N5450A Extreme Temperature Cable Extension	1-13
N2880A InfiniiMax In-Line Attenuator Kit	1-14
N2881A InfiniiMax DC Blocking Cap Kit	1-15
Replaceable Parts for the N5380A, N5381A, N5382A, and Probe Amps	1-16
Replaceable Parts and Additional Accessories for the E2669A	1-16
Specifications	1-19
Characteristics	1-20
InfiniiMax II Series Performance Characteristics with N5380A SMA Probe Head	1-22
Simplified Schematic for N5380A SMA Probe Head	1-23
CAT I: Secondary Circuits	1-23
General Characteristics	1-24
WEEE Compliance	1-24
Slew Rate Requirements for Different Technologies	1-25
Wire Dimensions	1-26
Resistor Dimensions	1-27
Solder-in 91 Ohm and 0 Ohm Full Bandwidth Resistors	1-27
Solder-in 150 Ohm and 0 Ohm Medium Bandwidth Resistors	1-28
Solder-in 91 Ohm Long Wired ZIF Resistor Leads	1-29
82 Ohm Resistor	1-30
Probe and Probe Head Dimensions	1-31
Probe Amp Dimensions	1-31
N5381A and N5382A Probe Head Dimensions	1-32
01131-62103 Solder-in Differential Probe Head Dimensions	1-32
N5425A ZIF Probe Head Dimensions with ZIF Tip Attached	1-33
N5451A ZIF Probe Head Dimensions with Long Wired ZIF Tip Attached	1-34
Calibrating the probe	1-35
Probe handling considerations	1-35
Cleaning the probe	1-35
Replacing the Wires on N5381A and N5382A Probe Heads	1-36
Tips for Using Browser Probe Heads	1-39
Tips for Using Solder-In Probe Heads	1-39
Replacing the Mini-axial Lead Resistors on Solder-In Tips	1-40
Replacement Procedure	1-40
Tips for Using Solder-In Probe Heads	1-42
Procedures and Soldering Tips for InfiniiMax Long Wired ZIF Tip Resistor Installation	1-43
Procedure for Breaking Off an Infiniimax Long Wire ZIF Tip from the Packaging Strip	1-46
Procedures and Soldering Tips for Using InfiniiMax ZIF and Long Wired ZIF Probe Heads	1-47
System Components	1-47
Overview of Soldering the ZIF Tip/Long Wired ZIF Tip into a DUT	1-48
Illustrated Procedure of Recommended Soldering Techniques	1-49
Using the N2887A / N2888A Soft Touch Probe Heads	1-53

Contents

Accessories / Replacement Parts	1-53
Compatibility	1-53
Characteristics	1-54
Probe Head Dimensions	1-54
N2887A Footprint Dimensions	1-55
N2888A Footprint Dimensions	1-56
E5405-68702 Retention Module Dimensions	1-57
E5405-68702 Retention Module Dimensions	1-57
N2887A / N2888A Plots	1-58
Pin-outs	1-59
N2887A/N2888A Calibration and Deskew Procedure	1-61
Using the N2884A InfiniiMax Fine Wire ZIF Tips	1-63
Step-by-Step Procedure For Using the Fine Wire ZIF Tips	1-65
Using the Extreme Temperature Cable Extension Kit (N5450A)	1-72
Using the N5380-64701 SMA Head Support	1-74
Using the N2880A InfiniiMax In-Line Attenuator Kit	1-75
Configuring Attenuators on an Infiniium Series Oscilloscope	1-76
N2881A InfiniiMax DC Blocking Caps	1-77
Using Probe Accessories	1-78
Solder-in Differential Probe Head (Full Bandwidth)	1-78
Differential Browser (Full Bandwidth)	1-79
Adjusting the Spacing of the Differential Browser Wires	1-79
N5380A SMA Probe Head (Full Bandwidth)	1-80
ZIF Probe Head (High Bandwidth)	1-80
Long Wired ZIF Probe Head	1-81
Socketed Differential Probe Head (High Bandwidth)	1-81
Differential Browser	1-82
Solder-in Single-ended Probe Head (High Bandwidth)	1-82
Single-ended Browser	1-83
Socketed Differential Probe Head with Damped Wire Accessory	1-83
Socketed Differential Probe Head with 01130-63201 Header Adapter	1-84

2 Differential and Single-ended Probe Configurations

Introduction 2-2

Convenience Accessories	2-3
Using the Velcro strips and dots	2-3
Using the ergonomic handle	2-3
Slew Rate Requirements for Different Technologies	2-6
Recommended Configurations Overview	2-9
1st Choice: Solder-in Differential Probe Head (full bandwidth)	2-11
2nd Choice: Differential Browser Probe Head (full bandwidth)	2-12
3rd Choice: SMA Probe Head (full bandwidth)	2-13
4th Choice: ZIF Probe Head	2-14
5th Choice: ZIF Probe Head with Long Wired ZIF Tip - 7mm Resistor Length	2-15
6th Choice: ZIF Probe Head with Long Wired ZIF Tip - 11 mm Resistor Length	2-16
Other Configurations Overview	2-17
7th Choice: Solder-in Differential Probe Head (high bandwidth resistors)	2-17
8th Choice: Socketed Differential Probe Head (high bandwidth resistors)	2-18
9th Choice: Differential Browser Probe Head	2-19
10th Choice: Solder-in Single-ended Probe Head (high bandwidth resistors)	2-20
11th Choice: Single-ended Browser Probe Head	2-21
12th Choice: Socketed Differential Probe Head with damped wire accessory	2-22

Detailed Information for Recommended Configurations 2-23

- 1 N5381A Solder-in Differential Probe Head (Full Bandwidth)
and 2 N5382A Differential Browser Probe Head (Full Bandwidth) 2-24
- 3 N5380A SMA Probe Head (Full Bandwidth) 2-28
- 4 N5425A ZIF Probe Head (Full Bandwidth) 2-31
ZIF Probe Head Accessory Impedance (N5426A) 2-34
- 5 and 6 ZIF Probe Head with N5451A Long-Wired ZIF Tip 2-35

Detailed Information for Other Configurations 2-46

- 7 E2677A Solder-in Differential Probe Head (High Bandwidth) 2-47
- 8 E2678A Socketed Differential Probe Head (High Bandwidth) 2-49
- 9 E2675A Differential Browser 2-51
- 10 E2679A Solder-in Single-ended Probe Head (High Bandwidth) 2-53
- 11 E2676A Single-ended Browser 2-55
- 12 E2678A Socketed Differential Probe Head with Damped Wire Accessory 2-57
- 13 E2695A SMA Probe Head 2-59
- N5380A SMA Probe Head with the 1134A InfiniiMax Probe 2-60
- N5381A Solder-in Differential Probe Head with 2 x Longer Wires 2-61
- N2887A/N2888A Soft Touch Probe Heads 2-62

3 Spice Models

- Input Impedance SPICE Models for N5425A, N5426A, N5381A, N5382A, and N2887A/N2888A Probe Heads 3-2
- Input Impedance SPICE Model for N5381A and N5382A Probe Heads 3-3
SPICE Deck 3-4
Measured and Modeled Data Matching 3-5
- Input Impedance SPICE Model for N5425A ZIF Probe Head with N5426A ZIF Tip Attached 3-6
SPICE Deck of N5425A with N5426A ZIF Tip Attached 3-7
Measured and Modeled Data Matching 3-8
- Input Impedance SPICE Model for N5426A ZIF Tip 3-9
SPICE Deck of N5426A 3-10
Measured and Modeled Data Matching 3-11
- Input Impedance SPICE Model for N2887A/N2888A Probe Heads 3-12

4 Service

- Service Strategy for the Probe 4-3
- To return the probe to Agilent Technologies for service 4-4
- Troubleshooting 4-5
- Failure Symptoms 4-6
Probe Calibration Fails 4-6
Incorrect Pulse Response (flatness) 4-6
Incorrect Input Resistance 4-6
Incorrect Offset 4-6
- Calibration Testing Procedures 4-7
- To Test Bandwidth 4-8
Using the 8720ES VNA successfully 4-8
Initial Setup 4-8
Calibrating a Reference Plane 4-9
Measuring Vin Response 4-14
Measuring Vout Response 4-16
Displaying Vout/Vin Response on 8720ES VNA Screen 4-17
- To Test Input Resistance 4-19
Initial Setup 4-19
Differential Test 4-20

Single-ended Test 4-21
Performance Test Record 4-23

1168A 10 GHz and 1169A 12 GHz InfiniiMax Active Probes

The 1168A and 1169A InfiniiMax Active Probes are probe solutions for high-frequency applications. The probes are compatible with the 90000 X-Series (requires the Agilent N5442A adapter), 90000A Series, 9000A Series, 80000 Series, 8000 Series, 54855A, and 54854A Infiniium AutoProbe Interface which completely configures the Infiniium series of oscilloscopes for the probes.

These probes are also compatible with the N1022A probe adaptor for use with the Infiniium 86100A Digital Communication Analyzer or for use with the 1143A external power supply.

N5381A 12 GHz Solder-in Differential Probe Head

Figure 1-1

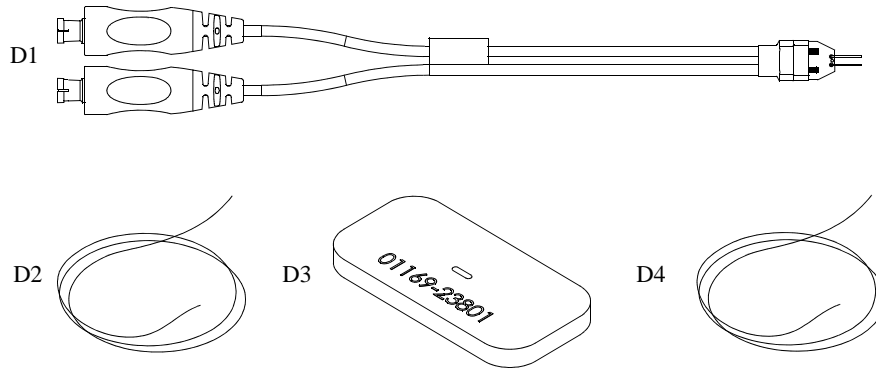

Some parts have been enlarged to show more detail.

N5381A 12 GHz Solder-in Differential Probe Head Accessories Supplied

Item	Description	Qty Supplied	Part Supplied
	Solder-in differential probe head kit consists of the following		N5381A
D1	Solder-in differential probe head	1	
D2	0.007 inch tin-plated nickel wire	1	01169-81301
D3	Trim gauge (comes as part of each wire package)	1	
D4	0.005 inch tin-plated nickel wire	1	01169-21306

Cut wire

Before using the wire, the two wires must be cut to the correct dimensions using the trim gauge. See instructions for *"Replacing the Wires on N5381A and N5382A Probe Heads"* on page 1-36.

General Information
N5382A 12 GHz Differential Browser Probe Head

N5382A 12 GHz Differential Browser Probe Head

Figure 1-2

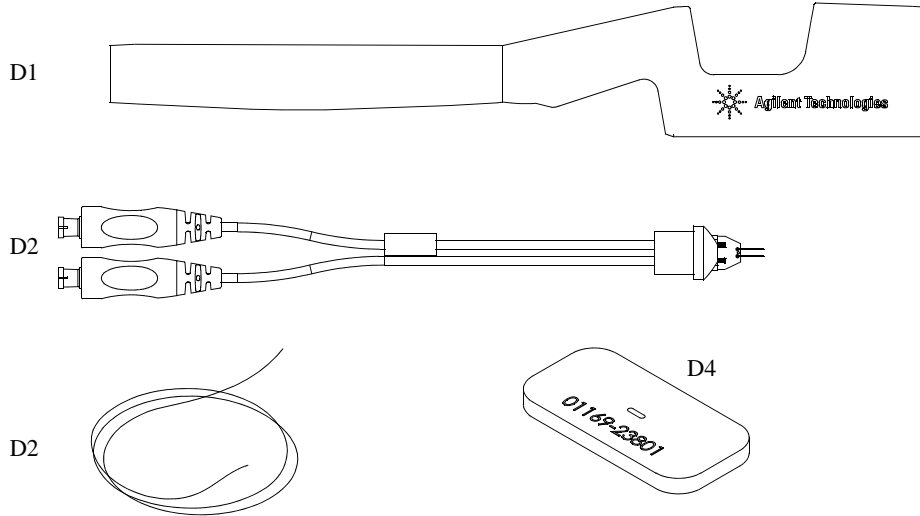

Some parts have been enlarged to show more detail.

N5381A 12 GHz Differential Browser Probe Head Accessories Supplied

Item	Description	Qty Supplied	Part Supplied
	Solder-in differential probe head kit consists of the following		N5382A
D1	Ergonomic handle	1	01130-43202
D2	Solder-in differential probe head	1	
D3	0.005 inch tin-plated steel wire	1	01169-21304
D4	Trim gauge (comes as part of the wire package)	1	

Cut wire

Before using the wire, the two wires must be cut to the correct dimensions using the trim gauge. See instructions for *"Wire Dimensions"* on page 1-26.

N5380A SMA Probe Head

Figure 1-3

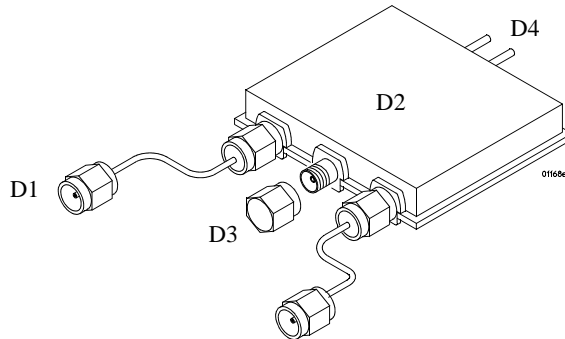

Some parts have been enlarged to show more detail.

N5380A 12 GHz SMA Probe Head Accessories Supplied

Item	Description	Qty Supplied	Part Supplied
	SMA probe head consists of the following		N5380A
D1	SMA-M to SMA-M cables	2	
D2	Probe Head PC Board	1	
D3	SMA shorting cap	1	
D4	GPO-F to GPO-F adaptor	2	

General Information
Related Product - N5380-64701 SMA Head Support

Related Product - N5380-64701 SMA Head Support

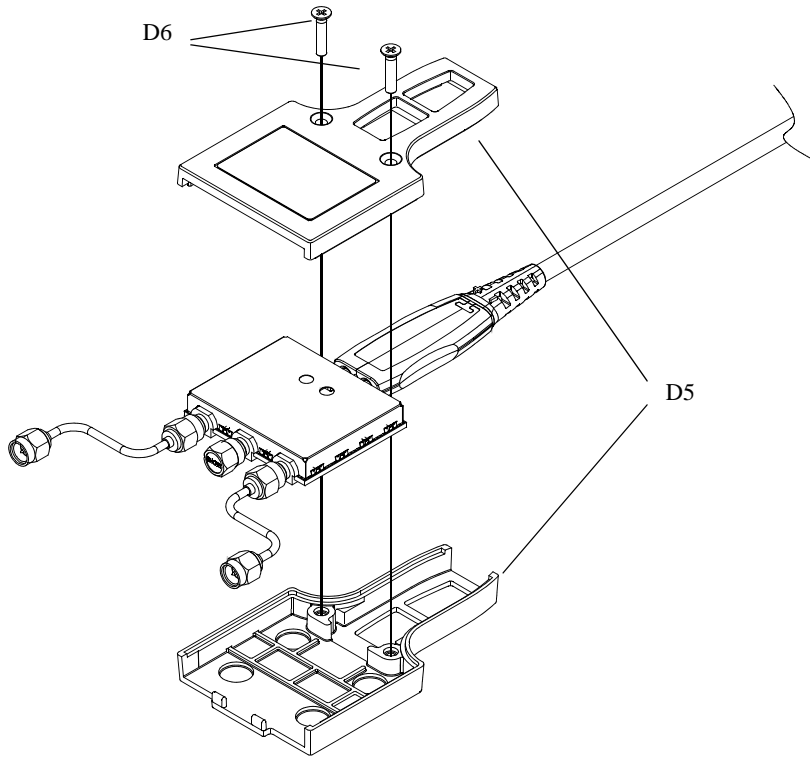

N5380-64701 SMA Head Support Accessories Supplied

Item	Description	Qty Supplied	Part Supplied
	SMA Head Support kit consists of the following		
D5	SMA Head Support	1	N5380-64701
D6	Screws for assembly (2 extra screws have been included)	4	0515-1236

N5425A ZIF Probe Head

Figure 1-4

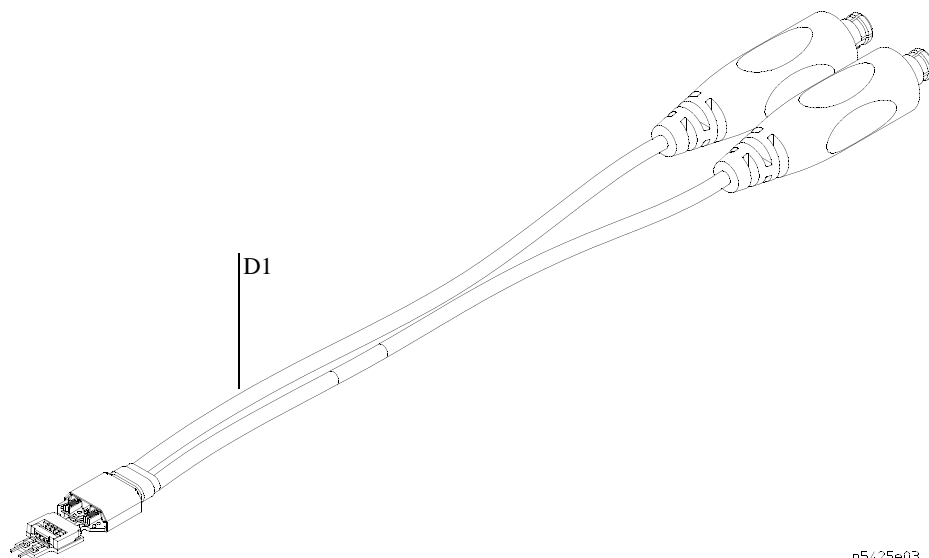

n5425e03

Some parts have been enlarged to show more detail.

N5425A 12 GHz ZIF Probe Head Accessories Supplied

Item	Description	Qty Supplied	Part Supplied
D1	SMA probe head consists of the following ZIF Probe Head	1	N5425A

The N5425A ZIF probe head does not include any ZIF probe tips. Either the N5426A ZIF tips, N5451A Long Wire ZIF tips, or N2884A Fine Wire ZIF tips should be ordered with the N5425A ZIF probe head.

General Information
Related Product - N5451A Long Wire ZIF Probe Tip

Related Product - N5451A Long Wire ZIF Probe Tip

Figure 1-5

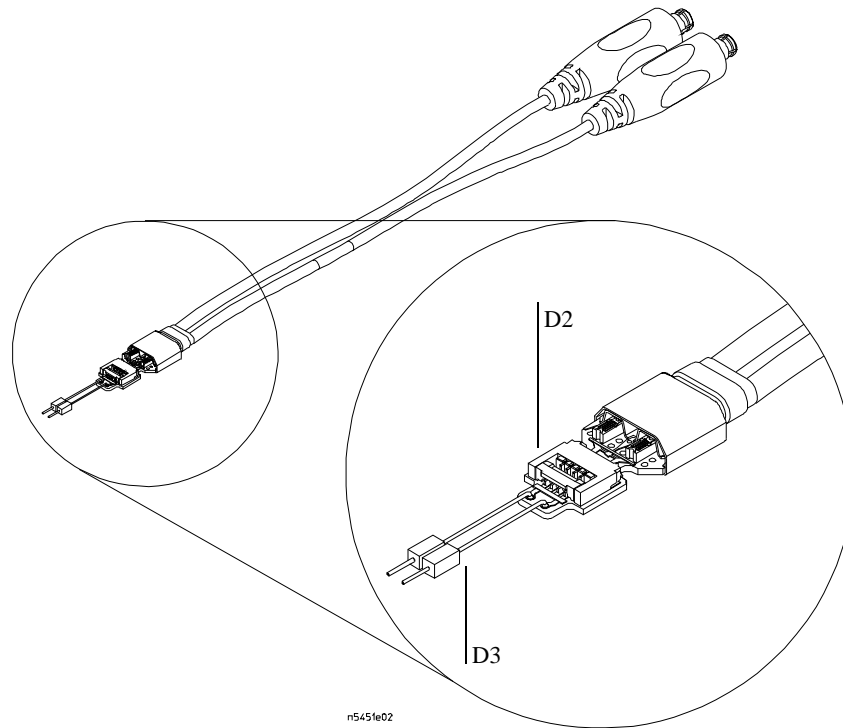

Some parts have been enlarged to show more detail.

N5451A Infiniimax Long Wire ZIF Probe Tip Accessories Supplied

Item	Description	Qty Supplied	Part Supplied
	Long Wire ZIF Probe Tip kit consists of the following		N5451A
D2	ZIF Tip	10	
D3	Long Wire ZIF Resistor Lead	24	01131-81510
	Trim Gauge (included as part of the packaging)	1	N5451A-94301

Cut wire

Before using the resistor leads, the two leads must be cut to the correct dimensions using the trim gauge and then soldered onto the Long Wire ZIF Tip. See instructions for *"Procedures and Soldering Tips for InfiniiMax Long Wired ZIF Tip Resistor Installation"* on page 1-43.

The Long Wire ZIF Probe Tip kit N5451A does not contain the ZIF probe head pictured above. It only contains the tip and resistor leads shown in the enlarged view.

Related Product - N2884A Fine Wire ZIF Probe Tip

Figure 1-6

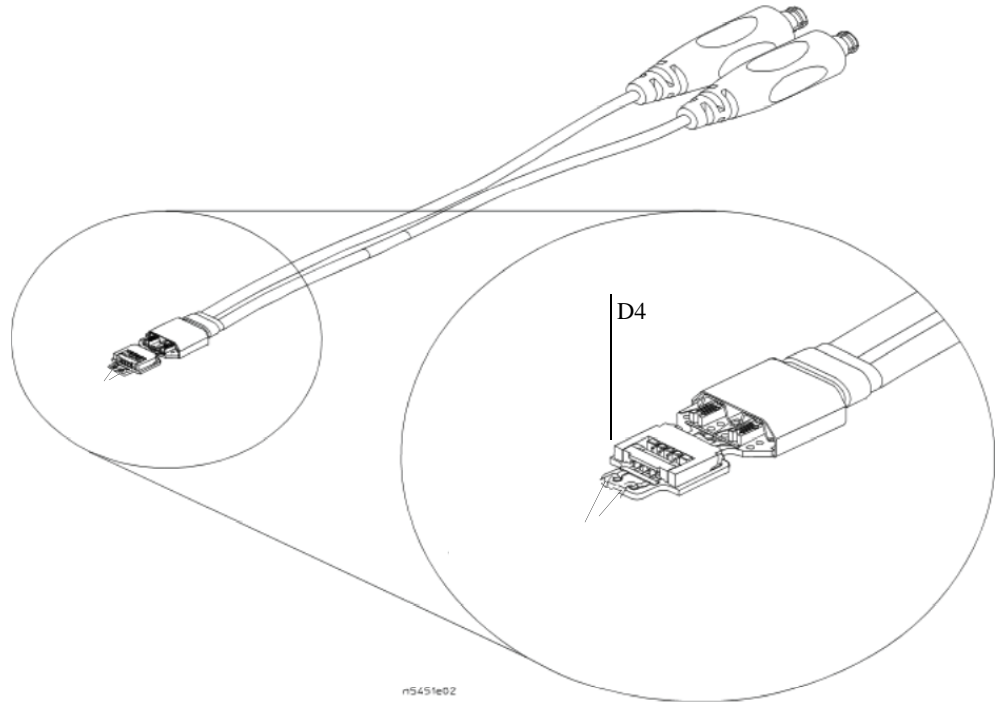

Some parts have been enlarged to show more detail.

N2884A Infiniimax Fine Wire ZIF Probe Tip Accessories Supplied

Item	Description	Qty Supplied	Part Supplied
	Fine Wire ZIF Probe Tip kit consists of the following		N2884A
D4	Fine Wire ZIF Tip	5	
	Positioner Arm with Thumb Nut	1	

The Fine Wire ZIF Probe Tip kit N2884A does not contain the ZIF probe head pictured above (N5425A). It only contains the tip with ZIF connector and fine wire leads (shown in the enlarged view).

General Information
Related Product - N2887A / N2888A Soft Touch Probe Heads

Related Product - N2887A / N2888A Soft Touch Probe Heads

Figure 1-7



N2887A Soft Touch Probe Head

N2888A Soft Touch Half-Channel Probe Head

N2887A/N2888A InfiniiMax Soft Touch Probe Heads

E2669A Differential Connectivity Kit

Figure 1-8

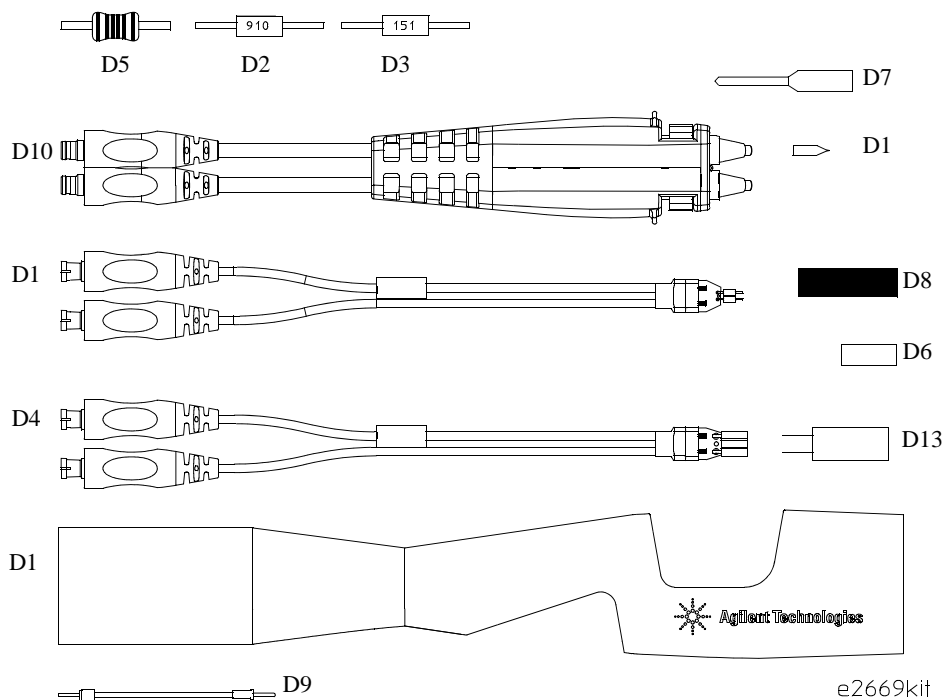

Some parts have been enlarged to show more detail.

E2669A Differential Connectivity Kit Accessories Supplied

Item	Description	Qty Supplied	Part Supplied
	Solder-in differential probe head kit consists of the following		E2677A
D1	Solder-in differential probe head	4	01131-62103
D2	Resistor for solder-in differential probe head full bandwidth, 91 Ω)	80	01131-81510
D3	Resistor for solder-in differential probe head medium bandwidth, 150 Ω)	40	01131-81506
	91 Ω resistor template	1	01131-94311
	150 Ω resistor template	1	01131-94308
	Socketed differential probe head kit consists of the following		E2678A
D4	Socketed differential probe head	2	01131-62105
D5	Resistor for socketed differential probe head full bandwidth, 82 Ω)	96	01130-81506
D6	Socket for 25 mil (25/1000 inch) square pins, female on both ends	8	01131-85201
D7	25 mil female socket w/20 mil round male pin on other end	8	01131-85202
D8	Heatshrink socket accessory	8	01130-41101
D9	160 Ω Damped wire accessory	12	01130-21302
D13	Header adapter	4	01130-63201
	82 Ω resistor template	1	01131-94309
	Differential browser kit consists of the following		E2675A
D10	Differential browser	1	01131-60002

General Information
E2669A Differential Connectivity Kit

Item	Description	Qty Supplied	Part Supplied
D11	Resistive tip for differential browser (blue)	20	01131-62102
D12	Ergonomic handle	1	01131-43201

Cut resistors

Before using the resistors, the resistor wires must be cut to the correct dimensions. For the correct dimensions see "*Resistor Dimensions*" on page 1-27

N5450A Extreme Temperature Cable Extension

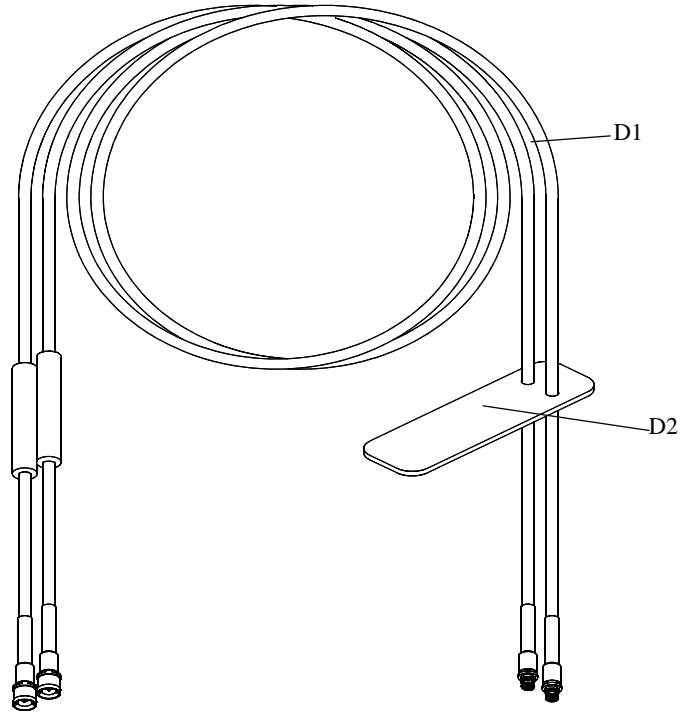

Some parts have been enlarged to show more detail.

N5450A Extreme Temperature Cable Extension Kit Accessories Supplied

Item	Description	Qty Supplied	Part Supplied
	Extreme Temperature Cable Extension kit consists of the following		N5450A
D1	Extreme Temperature Cable Extension	2	
D2	Coupling Tag	1	N5450-21201

General Information
N2880A InfiniiMax In-Line Attenuator Kit

N2880A InfiniiMax In-Line Attenuator Kit



D1

N2880A InfiniiMax In-Line Attenuator Kit Accessories Supplied

Item	Description	Qty Supplied	Part Supplied
	InfiniiMax In-Line Attenuator Kit consists of the following		N2880A
D1	6 dB Attenuator	2	
	12 dB Attenuator	2	
	20 dB Attenuator	2	

N2881A InfiniiMax DC Blocking Cap Kit



D1

N2881A InfiniiMax DC Blocking Cap Kit Accessories Supplied

Item	Description	Qty Supplied	Part Supplied
	InfiniiMax DC Blocking Cap Kit consists of the following		N2881A
D1	DC Blocking Cap	2	

General Information
Replaceable Parts for the N5380A, N5381A, N5382A, and Probe Amps

Replaceable Parts for the N5380A, N5381A, N5382A, and Probe Amps

Table 1-1

Agilent Replaceable Parts				
Agilent Part Number	Consists of	Orderable?	Description	Qty
1169A		Yes	12 GHz InfiniiMax Amp Kit	1
1168A		Yes	10 GHz InfiniiMax Amp Kit	1
01169-21304		Yes	0.005 steel wire and trim gauge (N5382A)	1
01169-81301		Yes	0.007 tin-plated nickel wire and trim gauge (N5381A)	1
01169-21306		Yes	0.005 tin-plated nickel wire and trim gauge (N5381A)	1
N5380A		Yes	SMA probe head	1

Table 1-2

N5380A Replaceable Parts			
Vendor	Part Number	Description	Qty
Corning Gilbert	#A1A1-0001-03	GPO-F to GPO-F adaptor	2
Rosenberger	#19K 109-K00 E4		

Replaceable Parts and Additional Accessories for the E2669A

Table 1-3

Connectivity Kit				
Agilent Part Number	Consists of	Orderable?	Description	Qty
E2669A		Yes	Differential Connectivity Kit consists of	1
	E2675A	Yes	Differential browser kit	1
	E2677A	Yes	Solder-in differential probe head kit	4
	E2678A	Yes	Socketed differential probe head kit	2
Probe Head Kits				
Agilent Part Number	Consists of	Orderable?	Description	Qty
E2675A		Yes	Differential browser kit	1
	01131-60002	No	Differential browser	1
	01131-62102	(Order E2658A accessory kit)	Resistive tip for browser (blue)	20
	01131-43201		Ergonomic handle for browser	1
E2677A		Yes	Solder-in differential probe head kit	1
	01131-62103	No	Solder-in differential probe head	1
	01131-81510	(Order E2670A accessory kit)	Resistor 91 Ω full bandwidth	20
	01131-81506		Resistor 150 Ω medium bandwidth	10
	01131-94311		91 Ω resistor template	1
	01131-94308		150 Ω resistor template	1

General Information
Replaceable Parts and Additional Accessories for the E2669A

E2678A		Yes	Socketed differential probe head kit	1
	01131-62105	No	Socketed differential probe head	1
	01130-63201	(Order E2671A accessory kit)	Header adapter	2
	01130-81506		Resistor 82 Ω full bandwidth	48
	01130-21302		160 Ω damped wire accessory	6
	01131-85201		Socket for 25 mil (25/1000 inch) square pins, female on both ends	4
	01131-85202		25 mil female socket w/20 mil round male pin on other end	4
	01130-41101		Heatshrink socket accessory	4
01131-94309		82 Ω resistor template	1	

Accessory Kits

Agilent Part Number	Consists of	Orderable?	Description	Qty
E2658A		Yes	Replacement accessories for E2675A	1
	01131-62102	No	Resistive tip for browser (blue)	20
	01131-43201	No	Ergonomic handle for browser	1
E2670A		Yes	Replacement accessories for E2677A	1
	01131-81510	No	Resistor 91 Ω full bandwidth	20
	01131-81506	No	Resistor 150 Ω medium bandwidth	10
	01131-94311	No	91 Ω resistor template	1
	01131-94308	No	150 Ω resistor template	1
E2671A		Yes	Replacement accessories for E2678A	1
	01130-81506	No	Resistor 82 Ω full bandwidth	48
	01130-21302	No	160 Ω damped wire accessory	6
	01130-63201	No	91 Ω header adapter	2
	01131-85201	No	Socket for 25 mil (25/1000 inch) square pins, female on both ends	4
	01131-85202	No	25 mil female socket w/20 mil round male pin on other end	4
	01130-41101	No	Heatshrink socket accessory	4
	01131-94309	No	82 Ω resistor template	1

Resistors

The Agilent number below is provided as a reference (not orderable) for you to order from the manufacturer.

Agilent Part Number	Order From Vendor	Orderable Part Number	Description	Qty
01131-81504	AVX Components	HR01000J	Resistor for solder-in single-ended probe head (full bandwidth, 0 Ω)	1
	BREL International	RMB16-000-J		
01131-81510	AVX Components	HR01910J	Resistor for solder-in single-ended probe head (high bandwidth, 91 Ω)	1
	BREL International	RMB16-910-J		
01130-81506	BC Components Vishay	2312 903 08209 SMA0204HF/ MK1HF5082R1 % A	Resistor for socketed differential probe head (high bandwidth, 82 Ω)	1

General Information
Replaceable Parts and Additional Accessories for the E2669A

Other Accessories			
Vendor	Part Number	Description	Qty
Cascade [®] Microtech	E2654A	EZ-Probe [®] positioner	1
Agilent	E2655B	Probe deskew and performance verification kit	1
Agilent	E5381-82103	160 Ω damped wire accessory (01130-21302 34 each)	1
Agilent	01131-68703	Header adapter kit for socketed differential probe head (01130-63201 10 each)	1
Inmet	#8037	SMA coaxial dc block	1
Inmet	#18AH-6	SMA 6 dB coaxial attenuator	1
Inmet	#18AH-12	SMA 12 dB coaxial attenuator	1
ATM Microwave	#P1907	SMA adjustable delay	1

Specifications

All specifications are warranted and are measured using the probe amp and N5381A solder-in differential probe head.

Table 1-4

Specifications

Bandwidth (-3 dB)

1168A > 10 GHz

1169A > 12 GHz (13 GHz typical)

Input Resistance

50 k Ω \pm 2%

25 k Ω \pm 2%

Differential mode resistance

Single-ended mode resistance each side to ground

Characteristics

All characteristics are the typical performance values of the InfiniiMax probes using the probe amp and N5381A solder-in differential probe head and are not warranted. Footnotes are located on page 21.

Typical Performance

Oscilloscope and Probe System

Bandwidth (-3 dB)

1168A with DSO80804A	8 MHz
1168A with DSO81004A	10 GHz
1169A with DSO81204A	12 GHz
1169A with DSO81304A	13 GHz

Rise and Fall Time (10% to 90%)

1168A	48 ps
1169A	40 ps

Rise and Fall Time (20% to 80%)

1168A	34 ps
1169A	28 ps

Rise and Fall Time (10% to 90%)

(Phase corrected on DSO80000 Series Oscilloscope)

1168A	42 ps
1169A	36 ps

Rise and Fall Time (20% to 80%)

(Phase corrected on DSO80000 Series Oscilloscope)

1168A	30 ps
1169A	25 ps

Input Capacitance

C_m	0.09 pF
C_g	0.26 pF

Model for input C is C_m is between tips and C_g is to ground for each tip

C_{diff}	0.21 pF
-------------------------	---------

Differential mode capacitance (capacitance when probing a differential signal = C_m + C_g/2)

C_{se}	0.35 pF
-----------------------	---------

Single-ended mode capacitance (capacitance when probing a single-ended signal = C_m + C_g)

Input Dynamic Range

±1.65 V

Differential or single-ended

Input Common Mode Range

±6.75 V

dc to 100 Hz

1.25 V peak-to-peak

> 100 Hz

Maximum Signal Slew Rate (SR_{max})¹

25 V/ns

When probing a single-ended signal

40 V/ns

When probing a differential signal

DC Attenuation

@ 3.45:1²

Zero offset error referred to input

< 2 mV x DC Attenuation²

Offset Range

±16.0 V

When probing single-ended

Offset Accuracy

< 3%²

Noise referred to input

2.5 mV_{rms}

Propagation Delay

@ 6 ns



Maximum Input Voltage 30 V Peak, CAT I Maximum non-destructive voltage on each input ground
ESD Tolerance > 8 kV from 150 pF, 330 Ω HBM

- 1 S_{rmax} of a sine wave = Amp $\times 2 \times \pi \times$ frequency or S_{Rmax} of a step @ Amp $\times 0.6 /$ trise (20 to 80%) for more information see Table 1-6 on page 25.
- 2 When calibrated on the oscilloscope, these characteristics are determined by the oscilloscope characteristics.

InfiniiMax II Series Performance Characteristics with N5380A SMA Probe Head

All characteristics are the typical performance values of the InfiniiMax probes using the probe amp and N5380A SMA probe head and are not warranted. Footnotes are located on page 22

Bandwidth	1169A: >12GHz	1168A: > 10GHz
Probe only rise and fall times	1169A: 27.5 ps (20% to 80%) 40 ps (10% to 90%)	1168A: 27.5 ps (20% to 80%) 40 ps (10% to 90%)
System rise and fall times¹	1169A with DSO81304A: 23 ps (20% to 80%) 33 ps (10% to 90%)	1168A with DSO81004A: 30 ps (20% to 80%) 42 ps (10% to 90%)
	1169A with DSO81204A: 25 ps (20% to 80%) 36 ps (10% to 90%)	1168A with DSO80804A: 38 ps (20% to 80%) 54 ps (10% to 90%)
System bandwidth (-3 dB)	1169A with DSO81304A: 12.5 GHz 1169A with DSO81204A: 12 GHz	1168A with DSO81004A: 10 GHz 1168A with DSO80804A: 8 GHz
Input Resistance	50 Ω \pm 2%	
Input dynamic range	\pm 1.1 V Differential or Single-Ended	
Maximum input⁴ (Vin-Vcm_term)	2.28 Vrms	
Input common mode range	\pm (4.3 V - Vcm_term) \mp 0.29 \pm 0.8 V	dc to 100 Hz > 100 Hz
Maximum Signal Slew Rate² (SMA attenuator can extend range. See footnote 3.)	25 V/ns	Differential Input
DC attenuation	~2.2:1 (-6.9db)	
Zero offset error referred to input	< 2 mV	
Noise referred to input	1.6 mVrms (~ 14 nV/rtHz using noise BW of 12.5 GHz)	
Propagation delay	~6.15 ns	

- Decreased rise and fall times mainly due to phase correction performed in the DSO80000 series, not due to DSP boosting (except in DSO81304A).
- SR max of sine wave = amplitude x 2 x π x frequency OR SR max of a step approximately equal to the amplitude x 0.6/trise (20-80%).
- Use of X:1 SMA coaxial attenuators in front of SMA probe head will:
 - Increase by X the max input signal slew rate, dynamic range, offset range, common mode range, noise referred to the input, DC attenuation, and maximum input voltage.
 - Most likely improve return loss or input TDR if attenuators are high quality
 - Not affect bandwidth and rise time if attenuators are high quality.
- Vcm_term is the voltage supplied to the common mode termination port of the N5380A. If shorting cap in place, this voltage is zero.

Simplified Schematic for N5380A SMA Probe Head

Figure 1-9

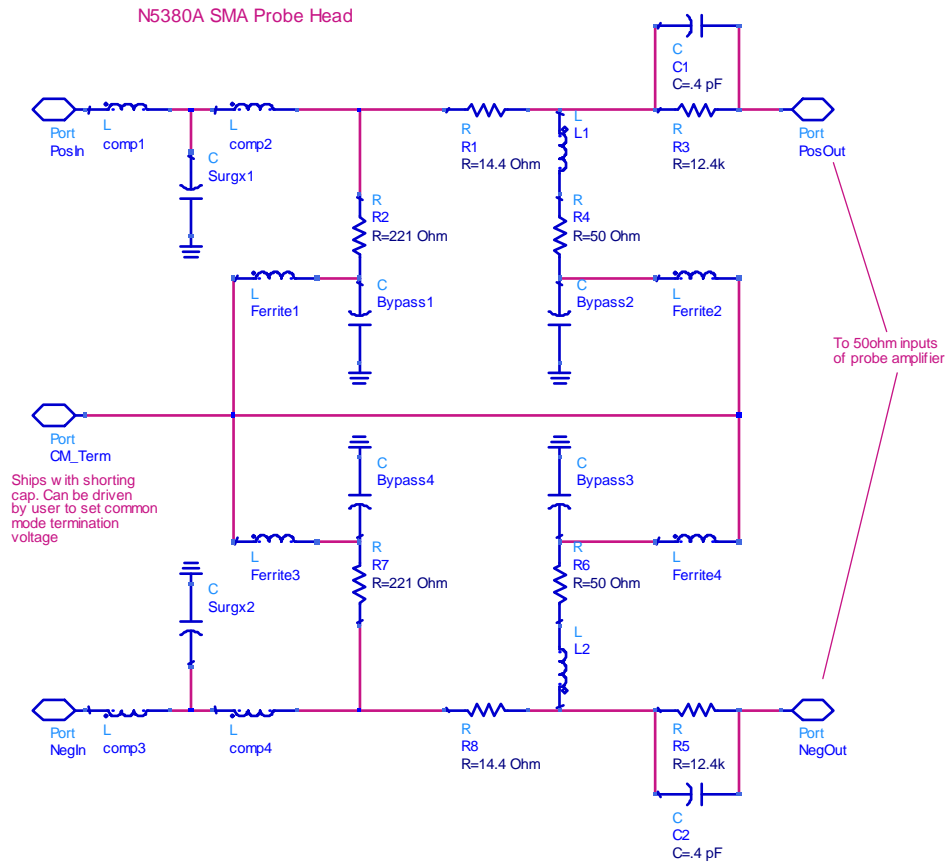

SMA Probe Head Simplified Schematic

CAT I: Secondary Circuits

Do not use the probe for measurements within measurement categories II, III and IV.
 The RATED transient overvoltage is 80 volts peak.

General Characteristics

The following general characteristics apply to the active probe.

Table 1-5

General Characteristics

Environmental Conditions

	Operating	Non-operating
Temperature	+5 °C to +40 °C	-40 °C to +70 °C
Humidity	up to 95% relative humidity (non-condensing) at +40 °C	up to 90% relative humidity at +65 °C
Altitude	Up to 4,600 meters	Up to 15,300 meters
Power Requirements	Voltages supplied by the Agilent oscilloscope AutoProbe interface.	
Weight	approximately 0.69 kg	
Dimensions	Refer to the outline in <i>figure 1-15</i> .	
Pollution degree 2	Normally only non-conductive pollution occurs. Occasionally, however, a temporary conductivity caused by condensation must be expected.	

Indoor use only

WEEE Compliance



This product complies with the WEEE Directive (2002/96/EC) marking requirements. The affixed label indicates that you must not discard this electrical/electronic product in domestic household waste.

Product Category: With reference to the equipment types in the WEEE Directive Annex I, this product is classed as a "Monitoring and Control Instrumentation" product.

Do not dispose in domestic household waste.

To return unwanted products, contact your local Agilent office, or see www.agilent.com for more information.

Slew Rate Requirements for Different Technologies

The following table shows the slew rates for several different technologies. The maximum allowed input slew rate is 25 V/ns for single-ended signals and 40 V/ns for differential signals. Table 1-6 shows that the maximum required slew rate for the different technologies is much less than that of the probe.

Table 1-6

Name of Technology	Differential Signal	Max Single-Ended Slew Rate ¹ ((V/ns)	Max Differential Slew Rate ² ((V/ns)	Driver Min Edge Rate (20%-80% (ps)	Max Transmitter Level (Diff V)
PCI Express (3GIO)	YES	9.6	19.2	50	1.6
RapidIO Serial 3.125Gb	YES	8.0	16.0	60	1.6
10GbE XAUI (4x3.125Gb)	YES	8.0	16.0	60	1.6
1394b	YES	8.0	16.0	60	1.6
Fibre Channel 2125	YES	8.0	16.0	75	1
Gigabit Ethernet 1000Base-CX	YES	7.8	15.5	85	2.2
RapidIO 8/16 2Gb	YES	7.2	14.4	50	1.2
Infiniband 2.5Gb	YES	4.8	9.6	100	1.6
HyperTransport 1.6Gb	YES	4.0	8.0	113	1.5
SATA (1.5Gb)	YES	1.3	2.7	134	0.6
USB 2.0	YES	0.9	1.8	375	1.1
DDR 200/266/333	NO	7.2	n/a	300	3.6
PCI	NO	4.3	n/a	500	3.6
AGP-8X	NO	3.1	n/a	137	0.7

1 The probe specification is 25 V/ns

2 The probe specification is 40 V/ns

Wire Dimensions

In order to make measurements with proper fidelity using the N5381A 12 GHz solder-in differential probe head or the N5382A 12 GHz differential browser probe head, the wire leads must be trimmed to a specified length as shown in figure 1-10. The procedure for trimming the wires is found in the section "Replacing the Wires on N5381A and N5382A Probe Heads" on page 1-36

Figure 1-10

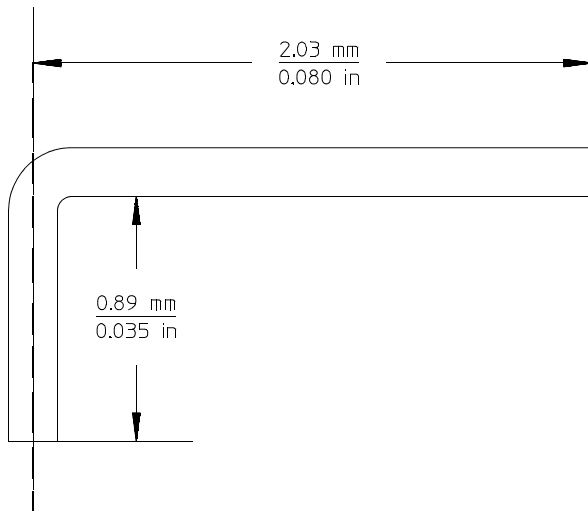

Resistor Dimensions

In order to make measurements with proper fidelity, the resistor leads must be trimmed to a specified length and one end bent 90 degrees as shown in figure 1-11, figure 1-12, and figure 1-13. The resistor in figure 1-14 needs to be trimmed but does not require any bending.

Solder-in 91 Ohm and 0 Ohm Full Bandwidth Resistors

The following part number resistors must be trimmed and bent as shown in figure 1-11.

- 01131-81510 (91 Ohm)
- 01131-81504 (0 Ohm)

The equipment required is:

- X-acto knife
- Agilent supplied template included with resistors
- Magnifying device
- Tweezers (2)

The instructions for trimming and bending the resistor are:

- 1 Using tweezers, place resistor body inside the rectangle of the trim template.
- 2 Using the X-acto knife, trim the leads even with the trim lines.
- 3 Place resistor body inside the rectangle of the bend template.
- 4 Using another pair of tweezers, bend the 1.90 mm (0.075 in) lead 90 degrees.

Figure 1-11

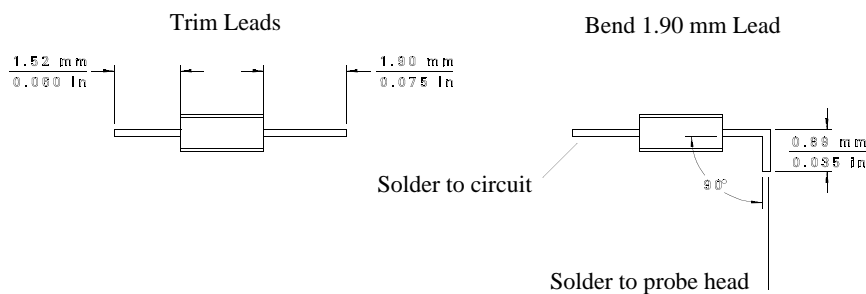

General Information

Resistor Dimensions

Solder-in 150 Ohm and 0 Ohm Medium Bandwidth Resistors

The following part number resistors must be trimmed and bent as shown in figure 1-12.

- 01131-81506 (150 Ohm)
- 01131-81504 (0 Ohm)

The equipment required is:

- X-acto knife
- Agilent supplied template included with resistors
- Magnifying device
- Tweezers (2)

The instructions for trimming and bending the resistor are:

- 1 Using tweezers, place resistor body inside the rectangle of the trim template.
- 2 Using the X-acto knife, trim the leads even with the trim lines.
- 3 Place resistor body inside the rectangle of the bend template.
- 4 Using another pair of tweezers, bend the 8.89 mm (0.360 in) lead 90 degrees.

Figure 1-12

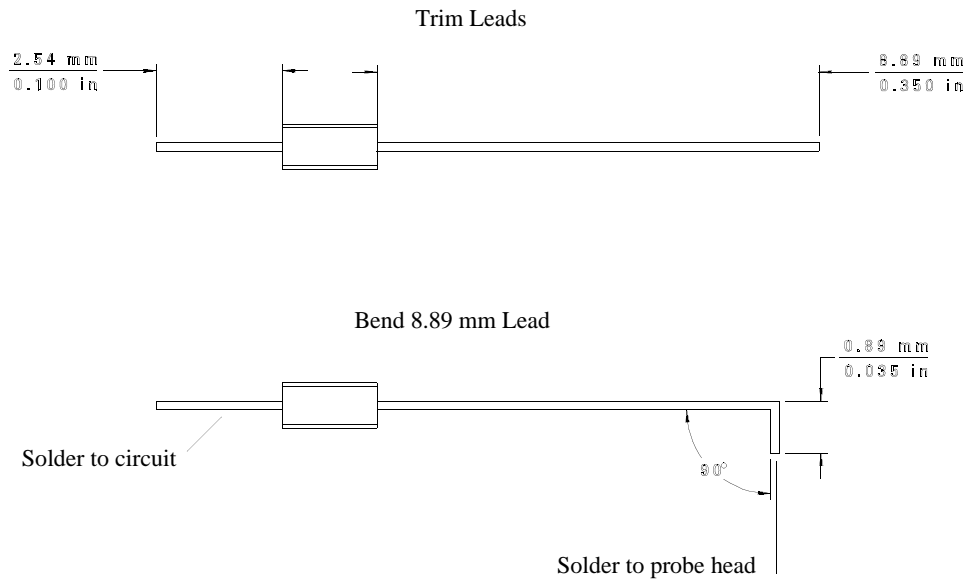

Solder-in 91 Ohm Long Wired ZIF Resistor Leads

The following part number resistors must be trimmed and bent using the template (N5451A-94301) provided with the N5451A packaging (see figure 1-13):

- 01131-81510 (91 Ohm)

The template shows how to trim the leads to two different lengths: 7 mm or 11 mm.

The equipment required is:

- X-acto knife
- Agilent supplied template gauge (N5451A-94301) included as part of the N5451A packaging
- Magnifying device
- Tweezers (2)

The instructions for trimming and bending the resistor are (for additional instructions and pictures regarding trimming, bending, and soldering these resistor leads, refer to "Procedures and Soldering Tips for InfiniiMax Long Wired ZIF Tip Resistor Installation" on page 1-43):

- 1 Using tweezers, place resistor body inside the rectangle of the trim template. The trim template contains two lengths: 7mm and 11mm. Choose the correct length for your application.
- 2 Using the X-acto knife, trim the leads even with the trim lines.
- 3 Place resistor body inside the rectangle of the bend template.
- 4 Using another pair of tweezers, bend the right-hand lead 90 degrees.

Figure 1-13

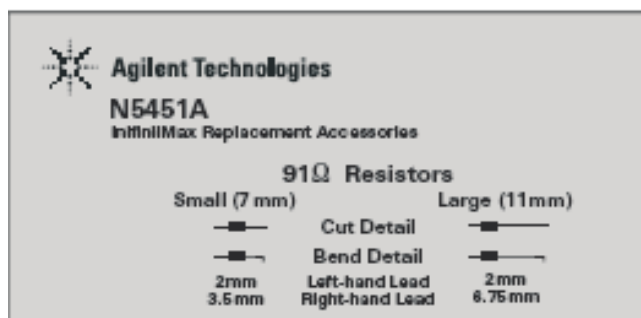

General Information

Resistor Dimensions

82 Ohm Resistor

The following part number resistors must be trimmed as shown in figure 1-14.

- 01130-81506

The equipment required is:

- diagonal cutters
- Agilent supplied template included with resistors
- Magnifying device
- Tweezers

The instructions for trimming the resistor are:

- 1 Using tweezers, place resistor body inside the rectangle of the trim template.
- 2 Using the diagonal cutters, trim the leads even with the trim lines.

Figure 1-14

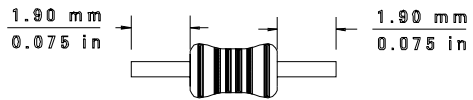

Probe and Probe Head Dimensions

Probe Amp Dimensions

Figure 1-15

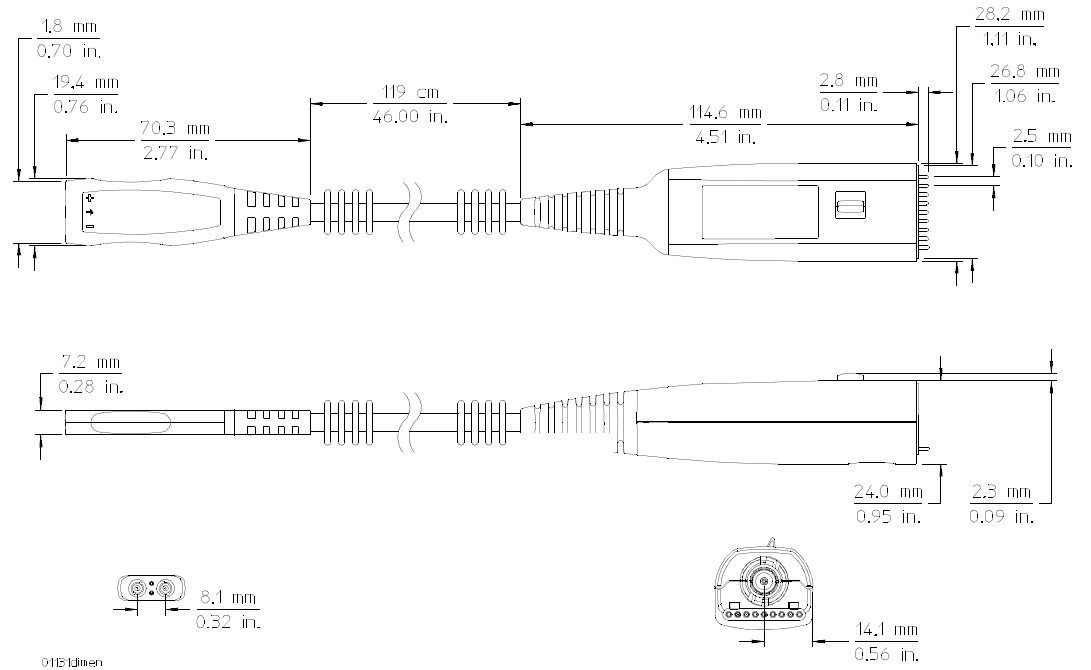

1168A and 1169A Active Probe Dimensions

General Information
Probe and Probe Head Dimensions

N5381A and N5382A Probe Head Dimensions

Figure 1-16

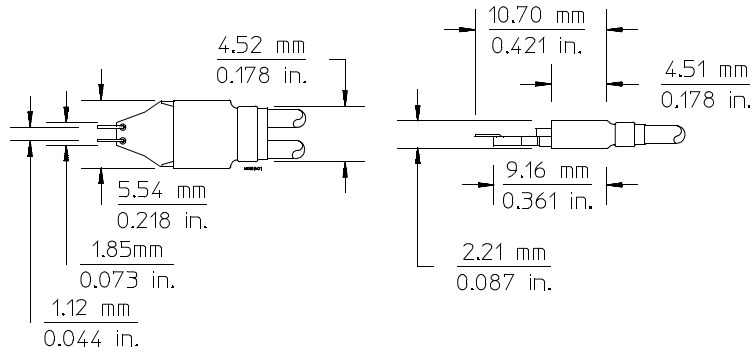

01131-62103 Solder-in Differential Probe Head Dimensions

Figure 1-17

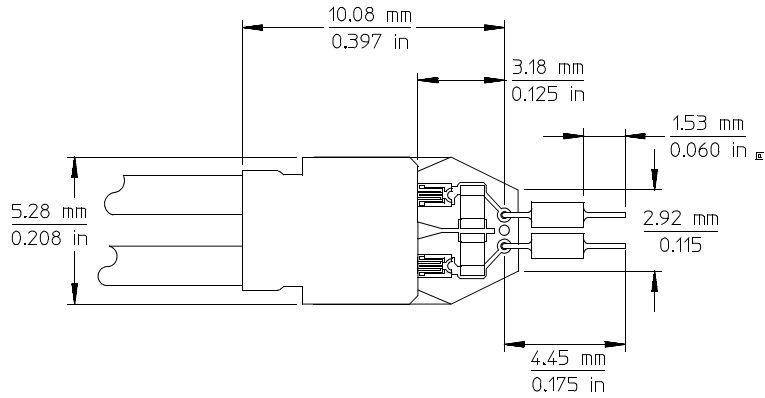

N5425A ZIF Probe Head Dimensions with ZIF Tip Attached

Figure 1-18

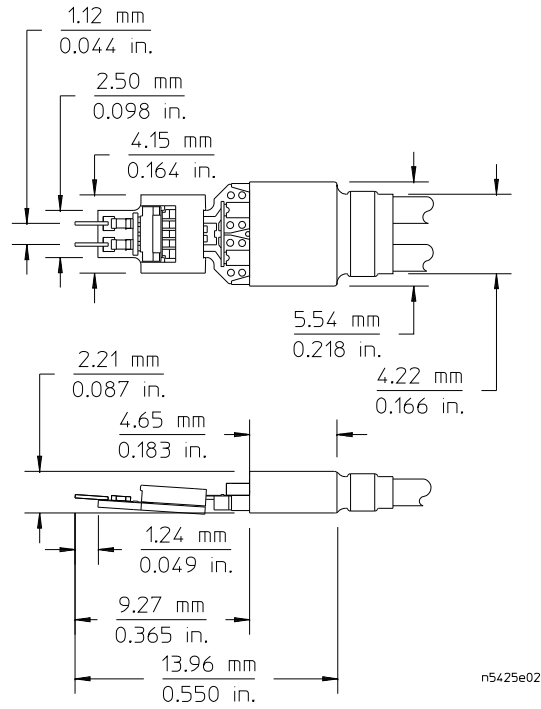

General Information
Probe and Probe Head Dimensions

N5451A ZIF Probe Head Dimensions with Long Wired ZIF Tip Attached

Figure 1-19

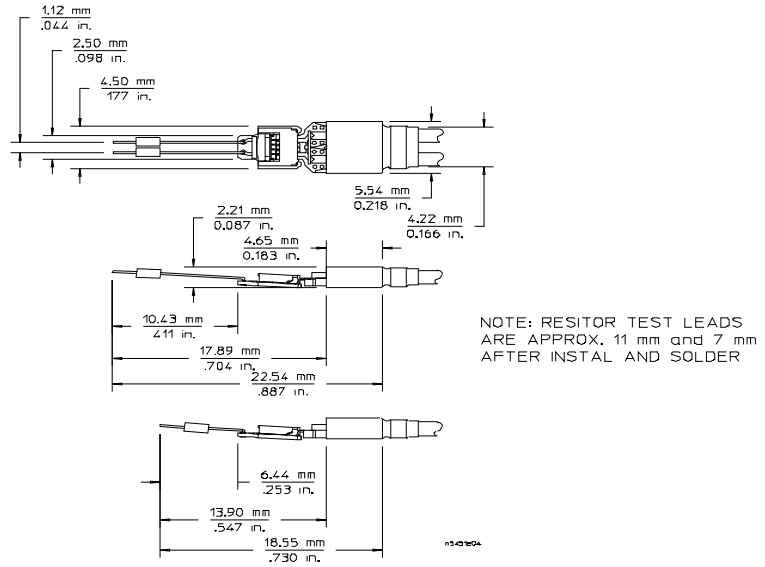

Calibrating the probe

The Infiniium family of oscilloscopes provides both power and offset control to the 1168A and 1169A active probes through the front panel connector. Probe offset is changed by adjusting the vertical offset control on the Infiniium oscilloscope. The control should be adjusted to center your signal within the 3.3 volt peak-to-peak (16 volts peak-to-peak for slow signals) dynamic range of the probe.

Before using the 1168A or 1169A probes, a calibration and deskew should be performed.

- 1 Connect the probe output to the oscilloscope input.**
- 2 Calibrate the oscilloscope and probe combination using the Infiniium probe calibration routine.**

When the probe has been calibrated, the dc gain, offset zero, and offset gain will be calibrated.

The degree of accuracy specified at the probe tip is dependent on the oscilloscope system specifications.

Probe handling considerations

This probe has been designed to withstand a moderate amount of physical and electrical stress. However, with an active probe, the technologies necessary to achieve high performance do not allow the probe to be unbreakable. You should treat the probe with care. It can be damaged if excessive force is applied to the probe tip. This damage is considered to be abuse and will void the warranty when verified by Agilent Technologies service professionals.

- Exercise care to prevent the probe end from receiving mechanical shock.
 - Store the probe in a shock-resistant case such as the foam-lined shipping case which came with the probe.
-

Cleaning the probe

If the probe requires cleaning, disconnect it from the oscilloscope and clean it with a soft cloth dampened with a mild soap and water solution. Make sure the probe is completely dry before reconnecting it to the oscilloscope.

General Information
Replacing the Wires on N5381A and N5382A Probe Heads

Replacing the Wires on N5381A and N5382A Probe Heads

When the wire leads of the N5381A and N5382A probe heads become damaged or break off due to use, the wires can be replaced. Use the appropriate wire for each probe head as follows:

- The N5381A uses the 0.007 inch tin-plated nickel wire. (01169-81301)
- The N5381A uses the 0.005 inch tin-plated nickel wire. (01169-21306)
- The N5382A uses the 0.005 inch tin-plated steel wire. (01169-21304)

The recommended equipment and procedure for replacing the wires is outlined below.

Table 1-7

Equipment

vise or clamp for holding tip

Metcal STTC-022 (600 °C) or STTC-122 (700 °C) tip soldering iron or equivalent. The 600 °C tip will help limit burning of the FR4 tip PC board.

0.381 mm (0.015 in) diameter RMA flux standard tin/lead solder wire

Fine stainless steel tweezers

Rosin flux pencil, RMA type (Kester #186 or equivalent)

Flush cutting wire cutters

Magnifier or low power microscope

Agilent supplied trim gauge (01169-23801)

Ruler

- 1** Use the vise or clamp to position the tip an inch or so off the work surface for easy access. If using a vise, grip the tip on the sides with light force. If using a tweezers clamp, grip the tip either on the sides or at the top and bottom. See figure 1-20.

CAUTION When tightening the vise, use light force to avoid damaging the solder-in probe head.

Figure 1-20

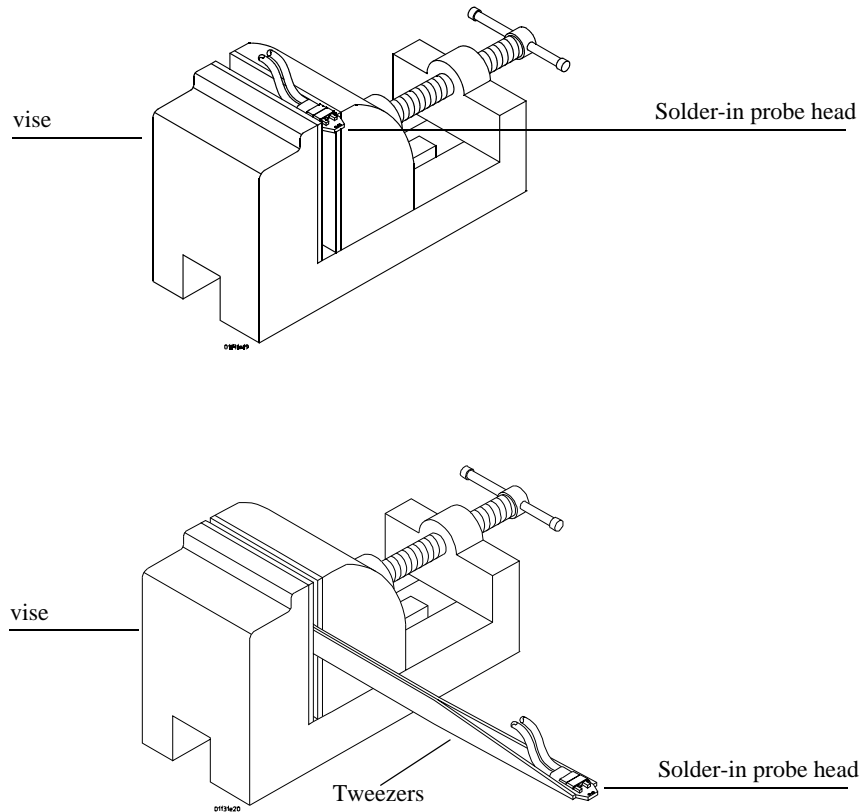

- 2 Make sure soldering iron tip is free of excess solder. Grab each wire lead with tweezers and pull very gently up. Touch the soldering iron to solder joint just long enough for the wire to come free of the probe head tip. Do not keep the soldering iron in contact with the tip any longer than necessary in order to limit burning and damage to the pc board. This solder joint has very low thermal mass so it should not take very long for the joint to melt and release.
- 3 Prepare the mounting hole(s) for new wire(s) by insuring that the holes are filled with solder. If they are not, use the soldering iron and solder to fill the holes. Again, do not leave the iron in contact with the tip any longer than necessary. When the hole(s) are filled with solder use the flux pencil to coat the solder joint area with flux.
- 4 Cut two wires to a length of about 12.7 mm (0.5 inches).
- 5 Using tweezers, put a 90 degree bend at the end of the wire. Leave enough wire at the bend such that it will protrude through the board when the wire is installed.
- 6 Holding the wire in one hand and the soldering iron in the other hand, position the end of the wire lead over the solder filled hole. Touch the soldering iron to the side of the hole. When the solder in the hole melts, the wire lead will fall into the hole. Remove soldering iron as soon as lead falls into the hole. Again, the thermal mass of the joint is very small so extra dwell time is not needed with the soldering iron to insure a good joint.
- 7 Cut the wires that protrude on the bottom side of the probe head board even with the solder pad.

General Information
Replacing the Wires on N5381A and N5382A Probe Heads

Figure 1-21

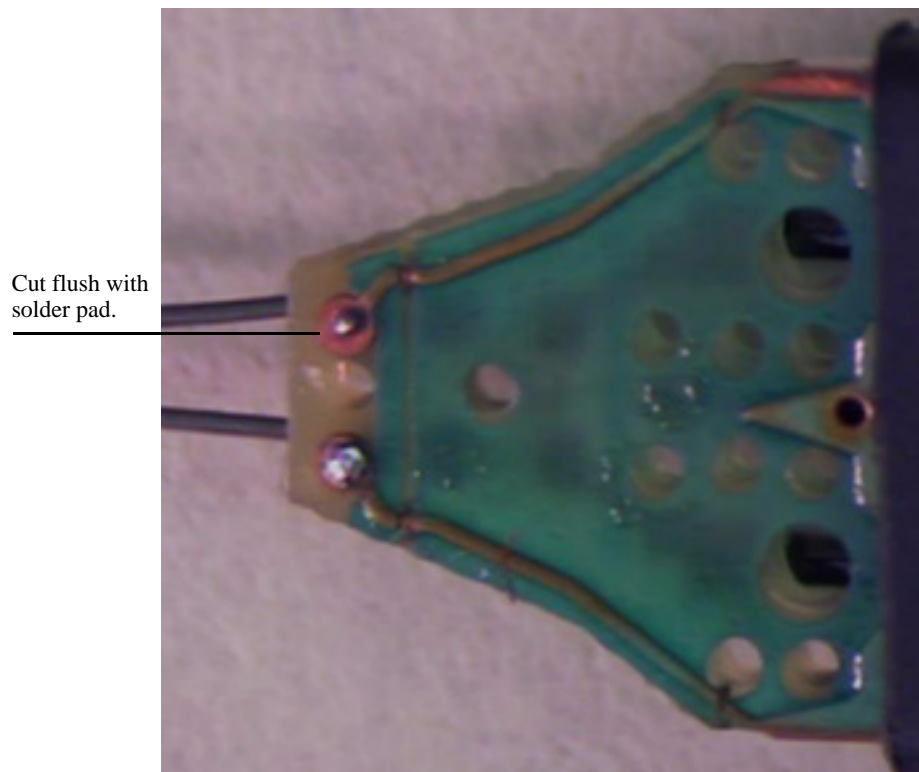

- 8 Place the wires through the hole in the trim gauge with the probe head perpendicular to the trim gauge.

Figure 1-22

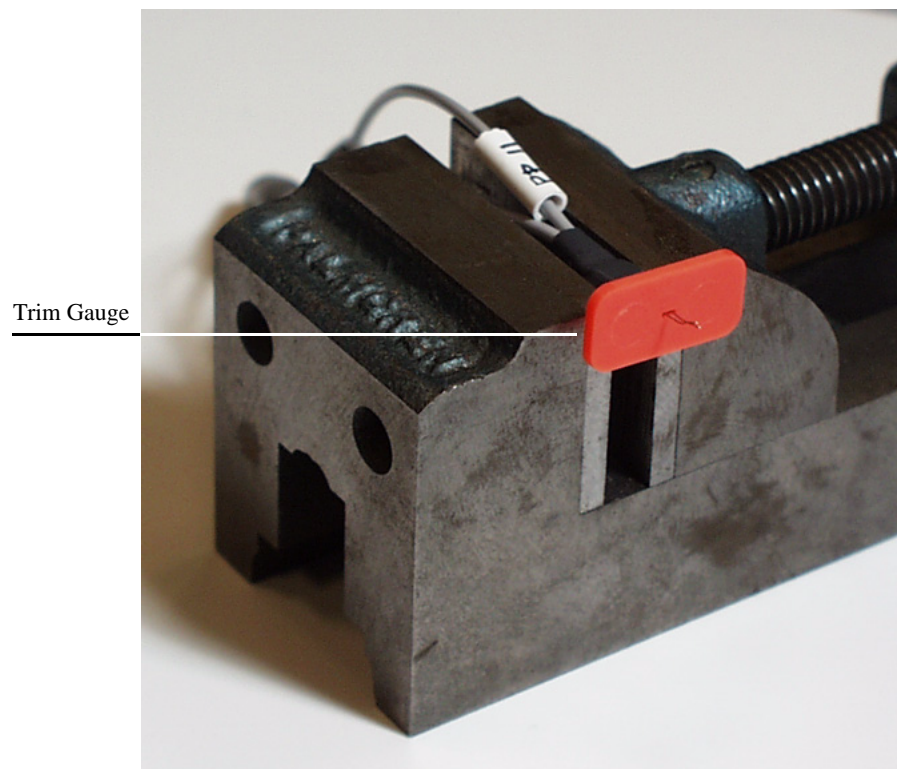

- 9 Cut the wires even with the trim gauge on the side opposite of the probe head.

Figure 1-23

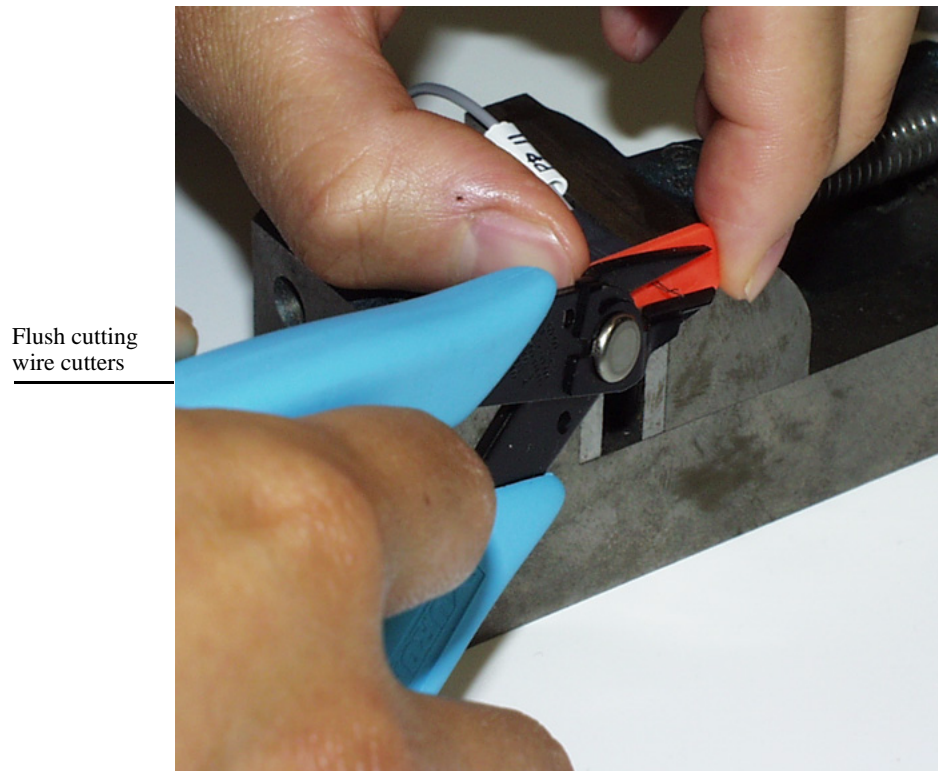

10 When replacing wires on the N5382A Browser, bend the wires down at about a 30 degree angle.

Figure 1-24

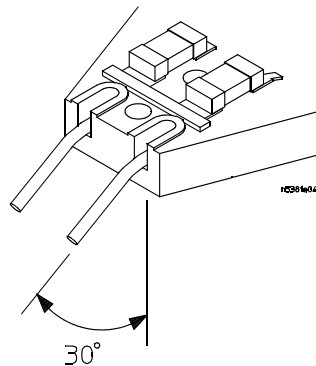

Tips for Using Browser Probe Heads

- Spring steel wires will last longer if the span is set by grabbing the lead near the pc board edge and twisting instead of just pulling or pushing the wires apart or together.

Tips for Using Solder-In Probe Heads

- When soldering in leads to DUT always use plenty of flux. The flux will insure a good, strong solder joint without having to use an excessive amount of solder.
- Strain relieve the micro coax leading away from the solder-in tips using hook-and-loop fasteners or adhesive tape to protect delicate connections.
- Note that for the differential solder-in probe head, the + and - connection can be determined when the probe head is plugged into the probe amplifier, therefore, it does not matter which way the tip is soldered.

General Information
Replacing the Mini-axial Lead Resistors on Solder-In Tips

Replacing the Mini-axial Lead Resistors on Solder-In Tips

When the leads of the mini-axial resistors become damaged or break off due to use, the resistors can be replaced. The recommended equipment and procedure for replacing the resistors is outlined below.

Table 1-8

Equipment

vise or clamp for holding tip

Metcal STTC-022 (600 °C) or STTC-122(700 °C) tip soldering iron or equivalent. The 600 °C tip will help limit burning of the FR4 tip PC board.

0.381 mm (0.015 in) diameter RMA flux standard tin/lead solder wire

Fine stainless steel tweezers

Rosin flux pencil, RMA type (Kester #186 or equivalent)

Diagonal cutters

Magnifier or low power microscope

Ruler

Replacement Procedure

- 1 Use the vise or clamp to position the tip an inch or so off the work surface for easy access. If using a vise, grip the tip on the sides with light force. If using a tweezers clamp, grip the tip either on the sides or top and bottom. See figure 1-25.

CAUTION When tightening the vise, use light force to avoid damaging the solder-in probe head.

Figure 1-25

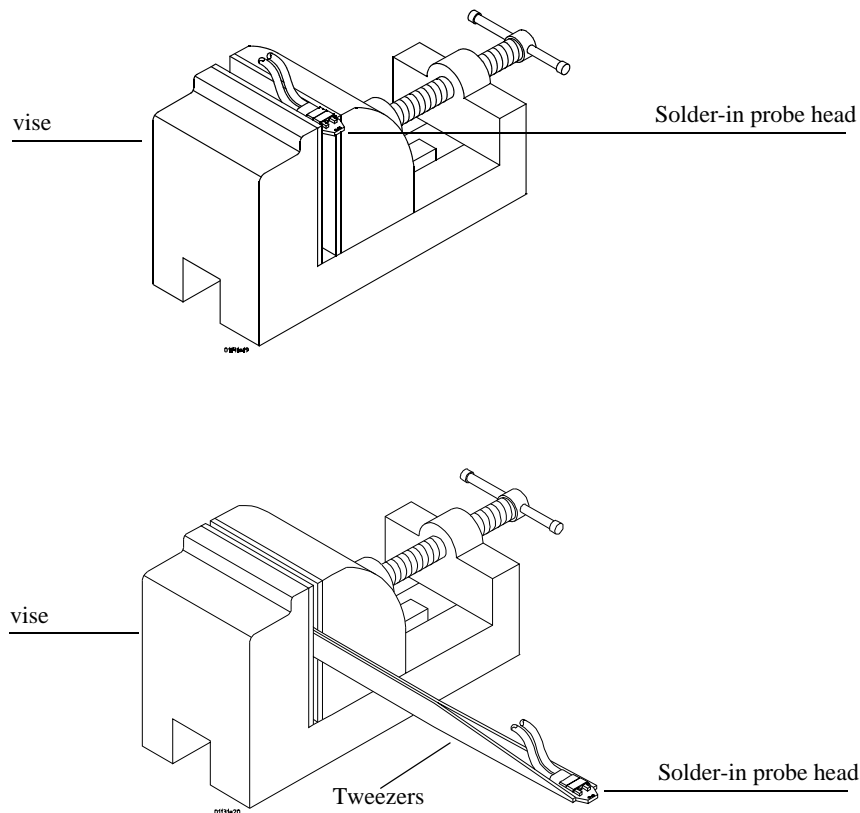

- 2 Make sure soldering iron tip is free of excess solder. Grab each resistor lead or body with tweezers and pull very gently up. Touch the soldering iron to solder joint just long enough for the resistor to come free of the probe head tip. Do not keep the soldering iron in contact with the tip any longer than necessary in order to limit burning and damage to the pc board. This solder joint has very low thermal mass so it should not take very long for the joint to melt and release.
- 3 Prepare the mounting hole(s) for new resistors or wires by insuring that the holes are filled with solder. If they are not, use the soldering iron and solder to fill the holes. Again, do not leave the iron in contact with the tip any longer than necessary. When the hole(s) are filled with solder use the flux pencil to coat the solder joint area with flux.
- 4 Prepare the mini-axial lead resistor for attachment to tip pc board. See "Resistor Dimensions" on page 1-27 for dimensions and directions on preparing resistor leads. Lead to be attached to tip pc board will have a 90 degree bend to go into through hole in the tip pc board.
- 5 Holding the resistor lead or wire in one hand and soldering iron in the other, position the end of the resistor lead (after the 90 degree bend) over the solder filled hole. Touch the soldering iron to the side of the hole. When the solder in the hole melts, the resistor lead will fall into the hole. Remove soldering iron as soon as lead falls into the hole. Again, the thermal mass of the joint is very small so extra dwell time is not needed with the soldering iron to insure a good joint.

General Information

Replacing the Mini-axial Lead Resistors on Solder-In Tips

Tips for Using Solder-In Probe Heads

- Do not solder in resistor leads with a big ball of solder right next to the resistor body. Normally the nickel lead will limit the heat transfer to the resistor body and protect the resistor, but if a ball of solder is right next to the resistor body on the lead, the resistor may come apart internally.
- When soldering leads to DUT always use plenty of flux. The flux will insure a good, strong solder joint without having to use an excessive amount of solder.
- Do not use the wrong value of resistor at the wrong length. See "Resistor Dimensions" on page 1-27 for dimensions and directions on preparing resistor leads.
- Make sure the zero ohm resistor is used for ground leads on the single-ended probe head.
- Strain relieve the micro coax leading away from the solder-in tips using hook-and-loop fasteners or adhesive tape to protect delicate connections.
- Note that for the differential solder-in probe head, the + and - connection can be determined when the probe head is plugged into the probe amplifier, so which way the tip is soldered in is not important.

Procedures and Soldering Tips for InfiniiMax Long Wired ZIF Tip Resistor Installation

Figure 1-26

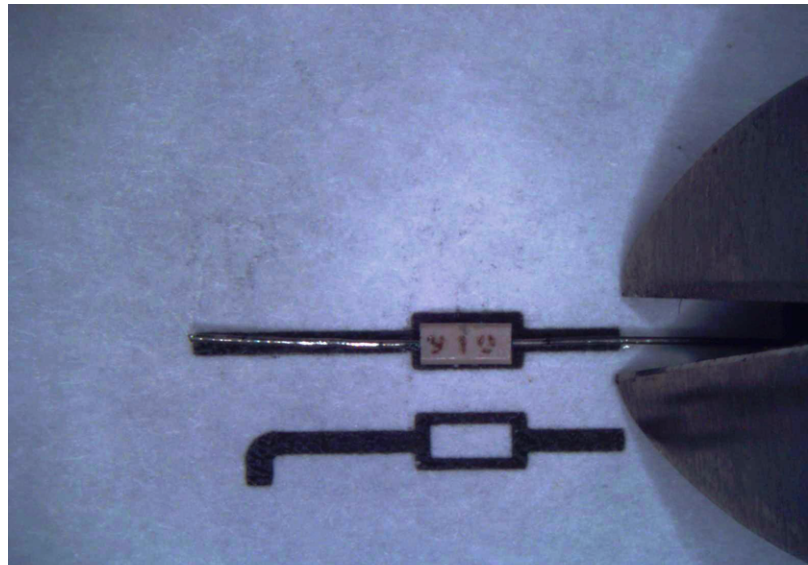

- 1 Choose a trim length of either 7 mm or 11 mm and use the corresponding trim guide dimensions to trim the resistor lead wires as shown in Figure 1-26. All measurements should be made from the corresponding resistor face datum. The included trim guide should be used for final length verification.

Figure 1-27

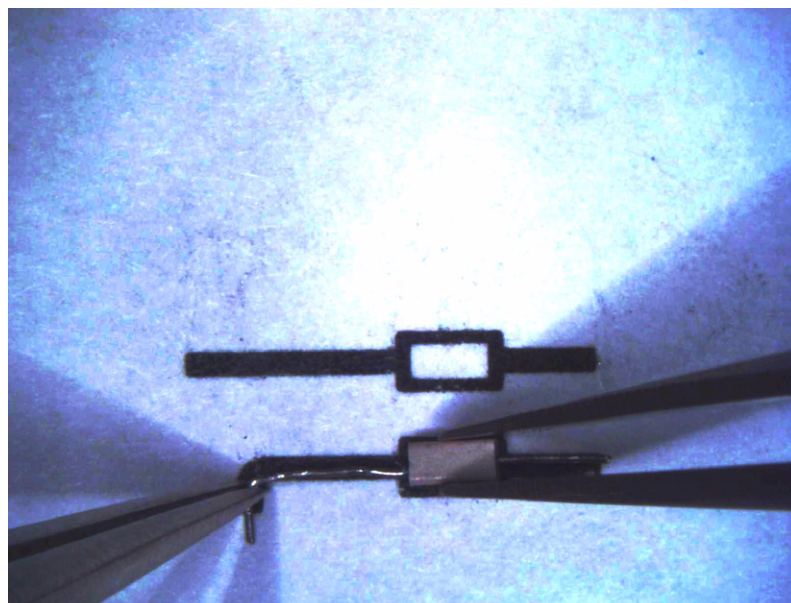

- 2 Bend the tip of the lead wire as shown in Figure 1-27 above. A sharp bend is preferred, but it should not exceed 90 degrees.

General Information
Procedures and Soldering Tips for InfiniiMax Long Wired ZIF Tip Resistor Installation

Figure 1-28

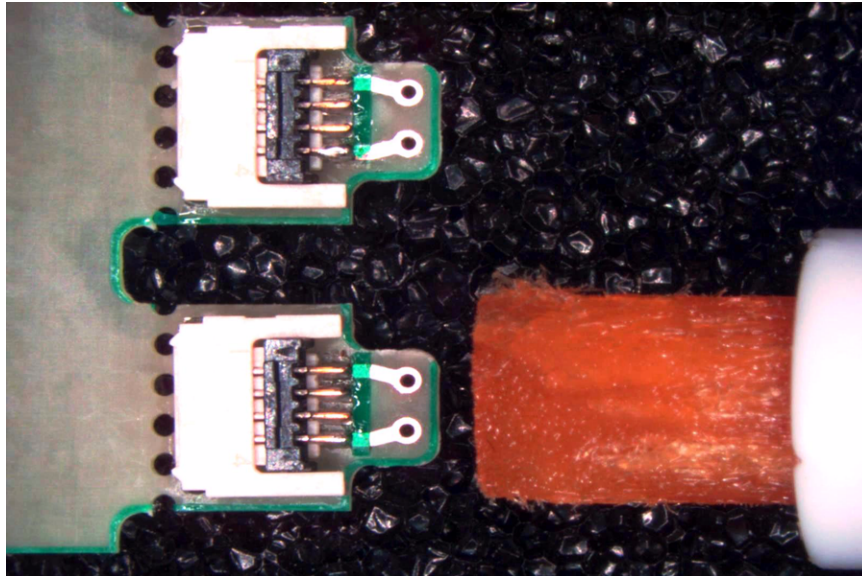

- 3 Use a flux pen to add flux to the circular traces on the board. Figure 1-29 below shows a good application of flux.

Figure 1-29

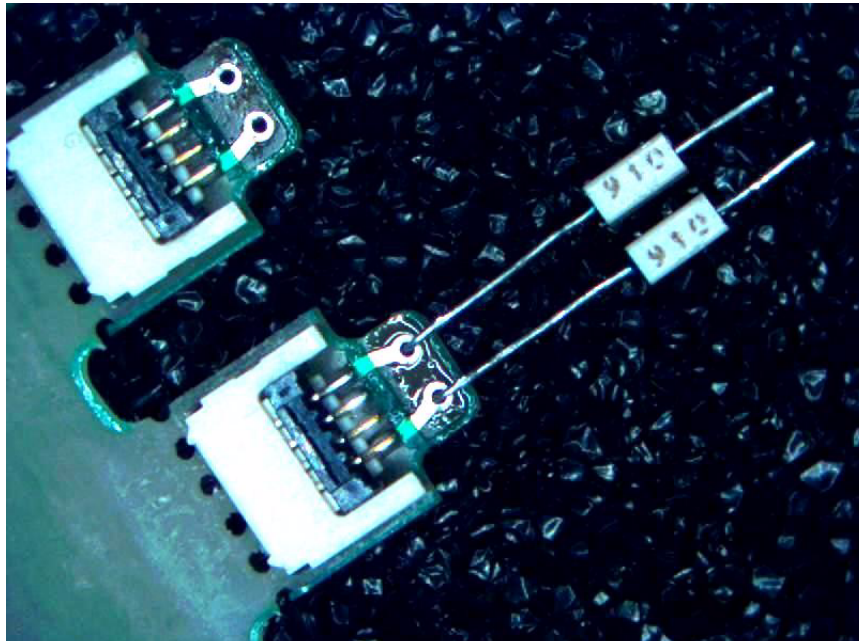

- 4 Insert one resistor into each through-hole of the circular traces on the board. Align the corresponding resistor faces. Figure 1-29 above shows both the resistors installed and aligned. Make length adjustments as needed.

Figure 1-30

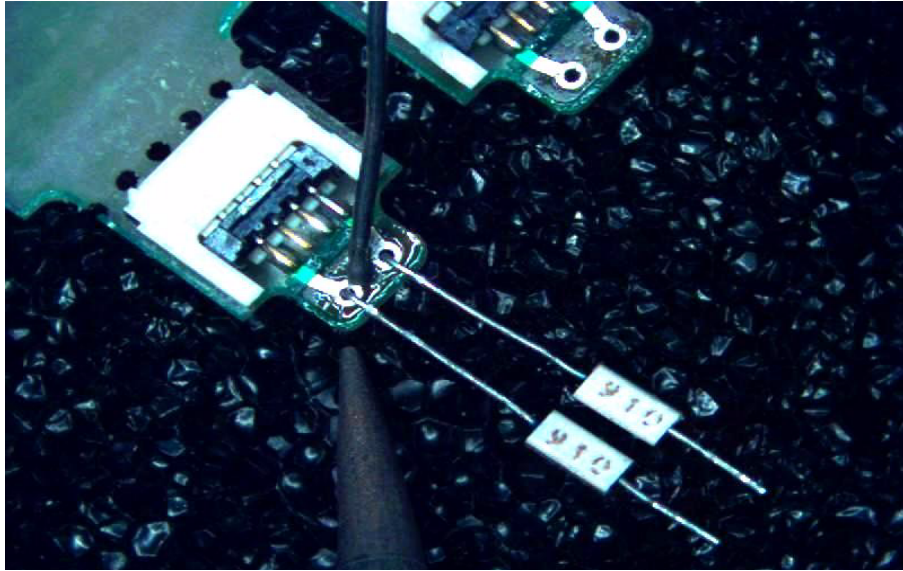

- 5 Momentarily apply the soldering iron tip to the resistor lead wires as shown in Figure 1-30. Touch the solder to the heated lead wire near the trace hole. Now remove both the solder and the soldering iron away from the Long Wired ZIF Tip. A good fillet should form around the lead wire, thus sealing the trace hole. Figure 1-31 shows good solder fillets surrounding the resistor lead wires. After soldering, clean board of any excess flux. Rotate the Long Wired ZIF Tip 180 degrees until the underside is facing up. Trim any excess lead wire protruding from the board.

Figure 1-31

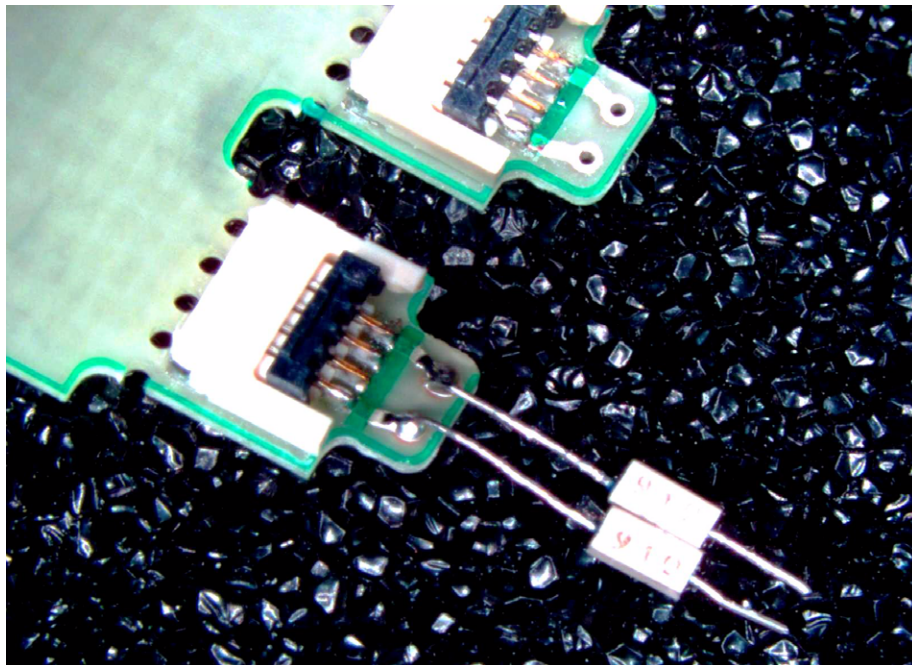

General Information
Procedure for Breaking Off an Infiniimax Long Wire ZIF Tip from the Packaging Strip

Procedure for Breaking Off an Infiniimax Long Wire ZIF Tip from the Packaging Strip

The Long Wire ZIF Tip kit N5451A contains ten ZIF tips connected together in a strip. Before a ZIF tip can be used, it must be separated from its strip. To accomplish this, grab one of the tips with flat nose tweezers and bend it back as shown in Figure 1-32. Then bend the tip in the opposite direction and it should break off. Figure 1-33 shows what the tip looks like after it has been separated from the strip.

Figure 1-32

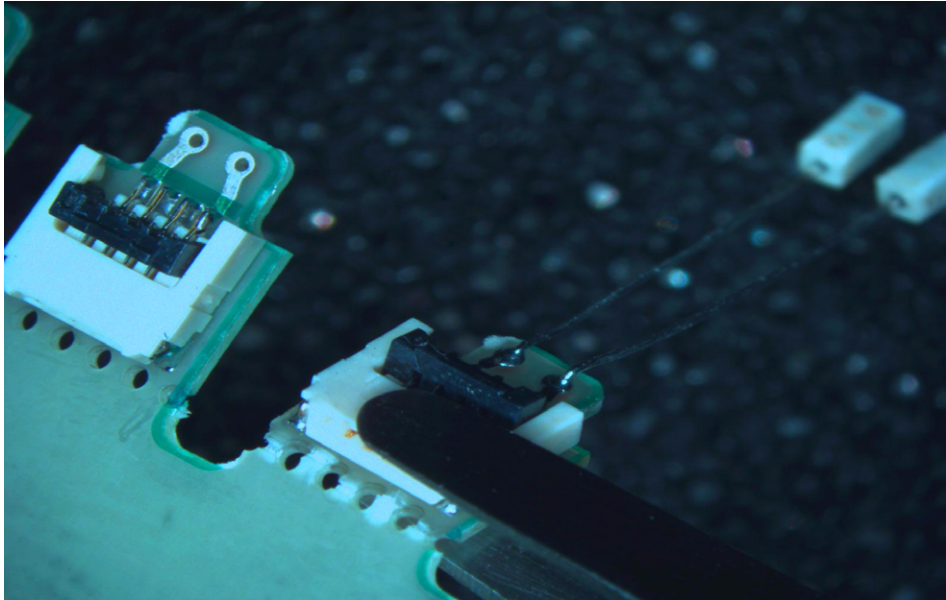
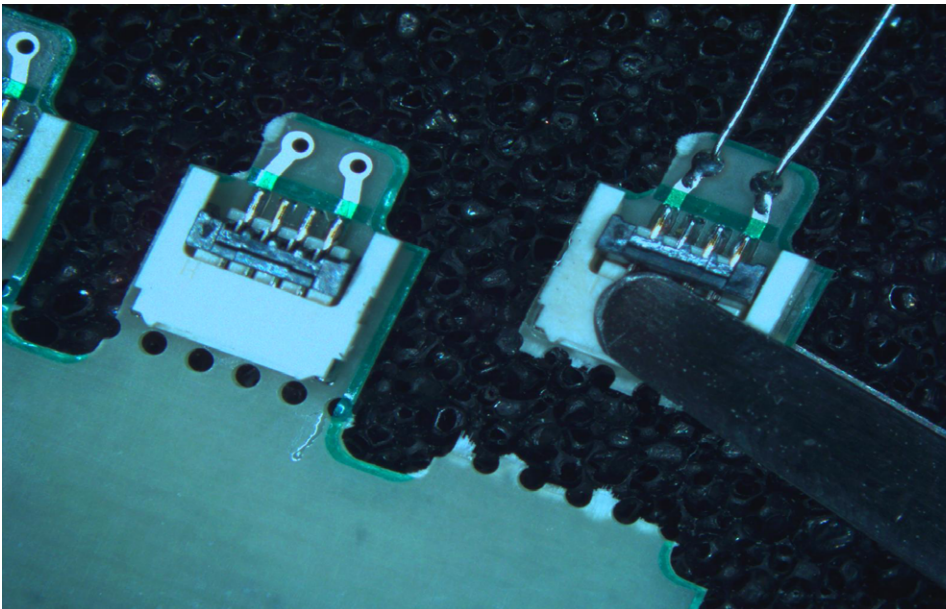

Figure 1-33



Procedures and Soldering Tips for Using InfiniiMax ZIF and Long Wired ZIF Probe Heads

The InfiniiMax ZIF (Zero Insertion Force) Probe Head system is a way to use a less expensive connection accessory (ZIF Tip) that can be installed at many locations on a device under test, to connect to a probe head (N5426A) that transports the signal to the probe amp. The advantages of this system are that the ZIF tip is very small and connects to the probe head using a zero insertion force connector. The small size is critical in probing tight locations and the zero insertion force feature allows connection without compressing the delicate wires which cannot support this compression.

The Long Wired ZIF tip allows for a greater span between the two resistor wires. The pictures below show the InfiniiMax ZIF Probe Head system, but the Long Wired ZIF Probe Head system would be soldered to the DUT in exactly the same manner.

System Components

The components of this system are shown in Figure 1-34.

Figure 1-34

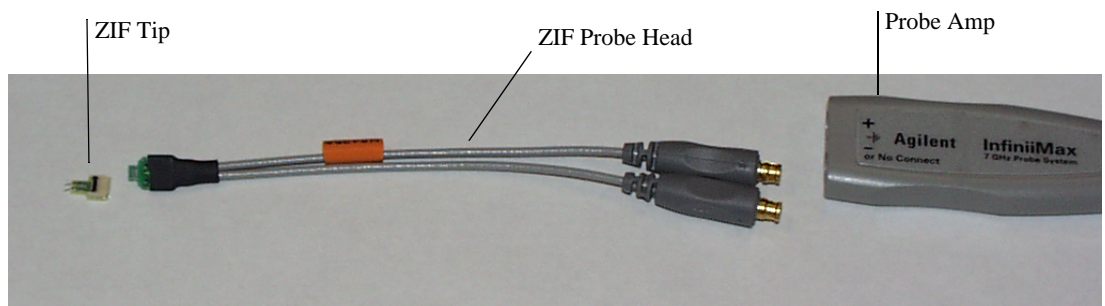

ZIF Probe Head System Components

A close-up of the ZIF Tip and the ZIF Probe Head before the probe head is inserted into the ZIF Tip is shown in Figure 1-35. Note that lever on the ZIF Tip is shown in the open position (pointed up) which allows the insertion of the probe head contacts into the ZIF Tip with zero insertion force.

Figure 1-35

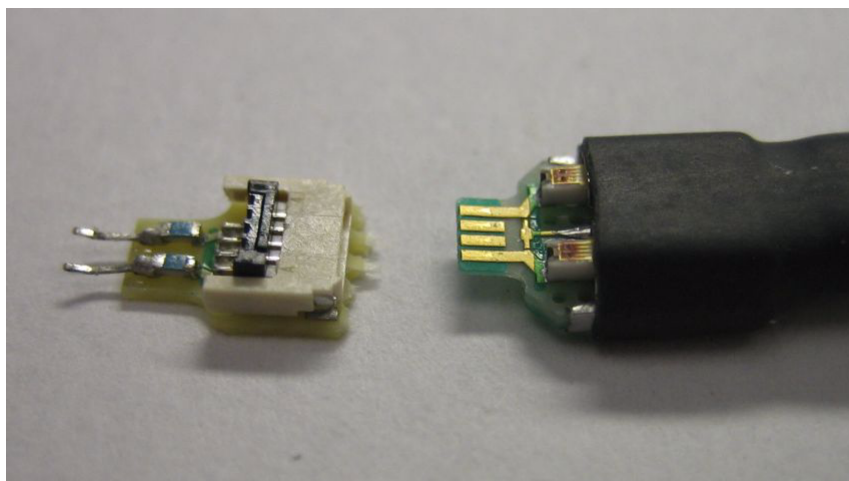

ZIF Tip (open position) and ZIF Probe Head

General Information

Procedures and Soldering Tips for Using InfiniiMax ZIF and Long Wired ZIF Probe Heads

A close-up of the ZIF Probe Head inserted into the ZIF Tip is shown in Figure 1-36. Note that now the lever on the Tip is in the closed position (down, rotated 90 degrees to the left) which closes the contacts of the ZIF connector.

Figure 1-36

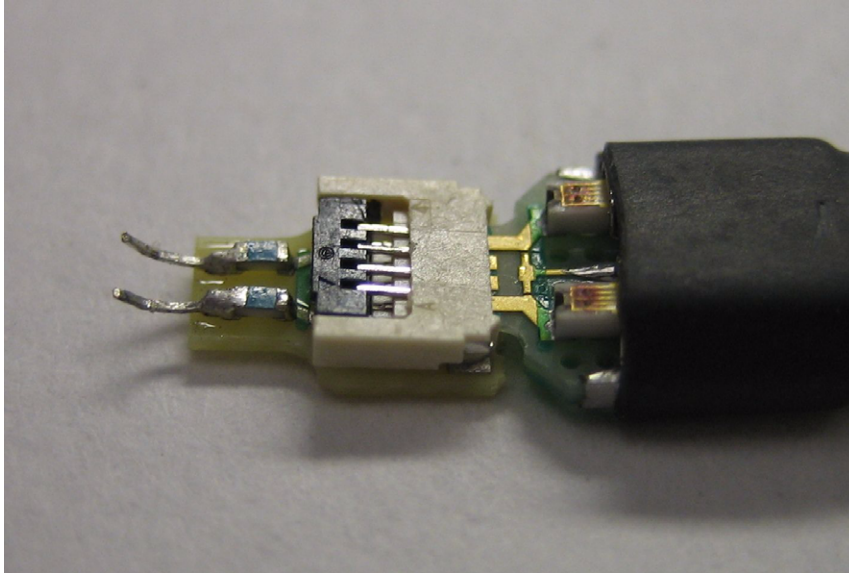

ZIF Tip (closed position) with ZIF Probe Head Inserted

Overview of Soldering the ZIF Tip/Long Wired ZIF Tip into a DUT

Soldering the Tip into a DUT is straightforward, but some of the traditional soldering techniques that are typically used on larger components will not work well here. Holding the leads on the ZIF Tip in place while applying the soldering iron and adding solder requires the use of three hands.

The following is an overview of the recommended soldering techniques

- 1 Add some solder to the DUT connection points. There should be enough solder to provide a good fillet around the ZIF Tip leads, but not so much as to create a big solder ball. A fine MetCal (or equivalent) soldering tip should be used along with some 11 or 15 mil solder.
- 2 Using a rosin flux pen, coat the solder points with flux. The flux core solder does not provide enough flux for this small scale soldering. Also, put flux on the tips of the leads of the ZIF Tip.
- 3 Clean the soldering tip well, then add a little bit of solder to the tip. It may take several tries to get just a little bit of solder right at or near the tip of the soldering iron. The solder on the tip keeps the soldering iron tip from pulling solder off the DUT connection points. This step may be optional if there is already enough solder on the DUT connection points.
- 4 Position a lead of the ZIF Tip on top of one of the target points, then briefly touch the soldering iron tip to the joint. The thermal mass of this joint is very small, so you don't need to dwell on the joint for very long. The flux that was added to the joint should produce a good, clean solder joint. If you don't get a good, shiny, strong solder joint, then there was either not enough flux or the joint was heated too long and the flux boiled off.
- 5 Repeat step 4 for the other lead of the ZIF Tip.
- 6 There is a possibility that if a lead of the ZIF Tip is inserted into a large ball of solder that is heated excessively with a soldering iron, the solder joint holding the lead onto the ZIF Tip pc board could flow and the lead would come off destroying the ZIF Tip. Only the first third of the lead or so needs to be soldered to the target point.

Illustrated Procedure of Recommended Soldering Techniques

An illustrated example of the installation of a ZIF Tip and connection to a ZIF Probe Head is shown below. Figure 1-37 shows a IC package which we will attach a ZIF Tip to the first two package leads. The target could also be via pads or signal traces.

Figure 1-37

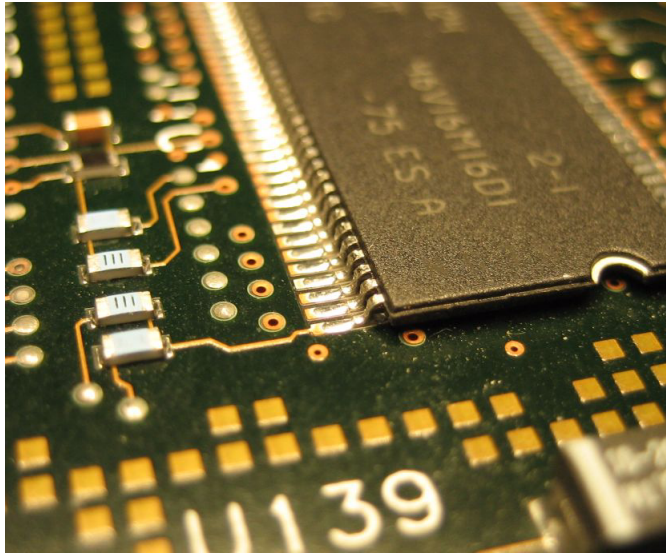

IC Package for Example ZIF Tip Installation

- 1 Add some solder to the target points in the DUT. Figure 1-38 shows extra solder added to the pads for the first two pins on an IC package.

Figure 1-38

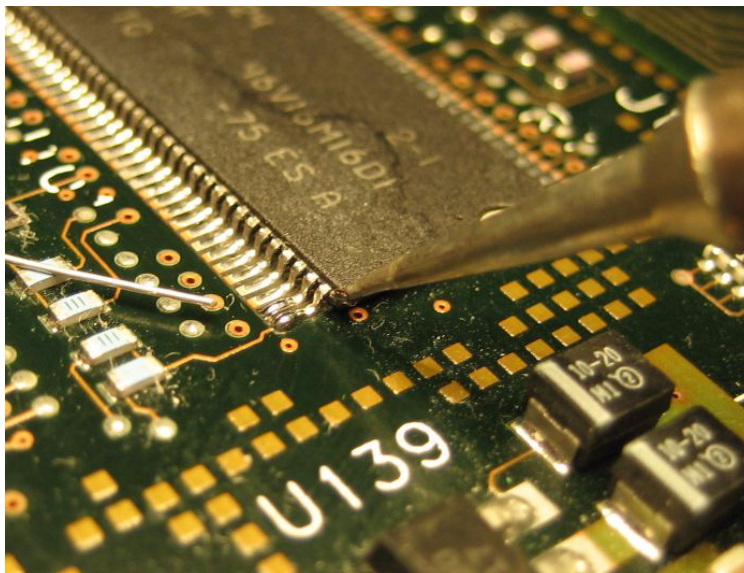

Solder Added to Target Points

- 2 Use flux pen to add flux to the target points. Also, flux the tip of the lead on the ZIF Tip at this time. Figure 1-39 shows the target points after they have been fluxed in preparation for soldering.

General Information
Procedures and Soldering Tips for Using InfiniiMax ZIF and Long Wired ZIF Probe Heads

Figure 1-39

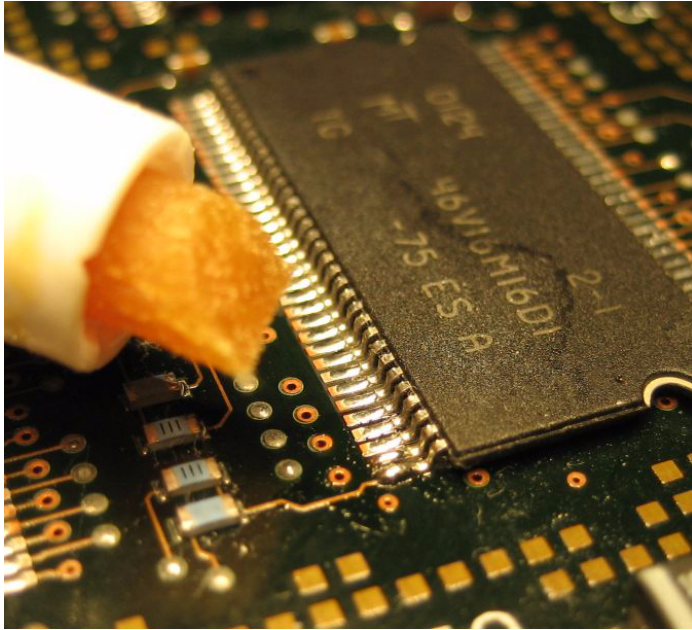

Fluxing of the Target Points

- 3 Clean the soldering iron tip and add a small amount of solder to the very tip. This may take a few tries because the solder may tend to ball up and move away from the tip. Figure 1-40 shows a small amount of solder on the tip of the soldering iron.

Figure 1-40

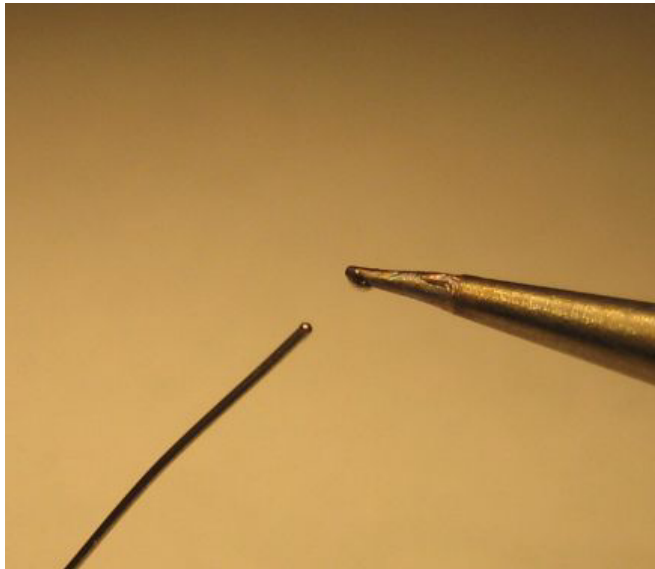

Small Amount of Solder Added to ZIF Tip of Soldering Iron

- 4 Installation of ZIF Tip. Connect the ZIF Tip to the ZIF probe head as shown in Figure 1-35 and Figure 1-36 above. This allows the probe head to be used as a handle for the ZIF Tip to allow positioning in the DUT. Position the lead wires on the target points and then briefly heat the solder joints. There should be enough solder to form a good fillet and enough flux to make the joint shiny. There shouldn't be so much solder that the big solder ball is formed that could cause a solder bridge or overheat the leads on the ZIF Tip. This is shown in Figure 1-41.

Figure 1-41

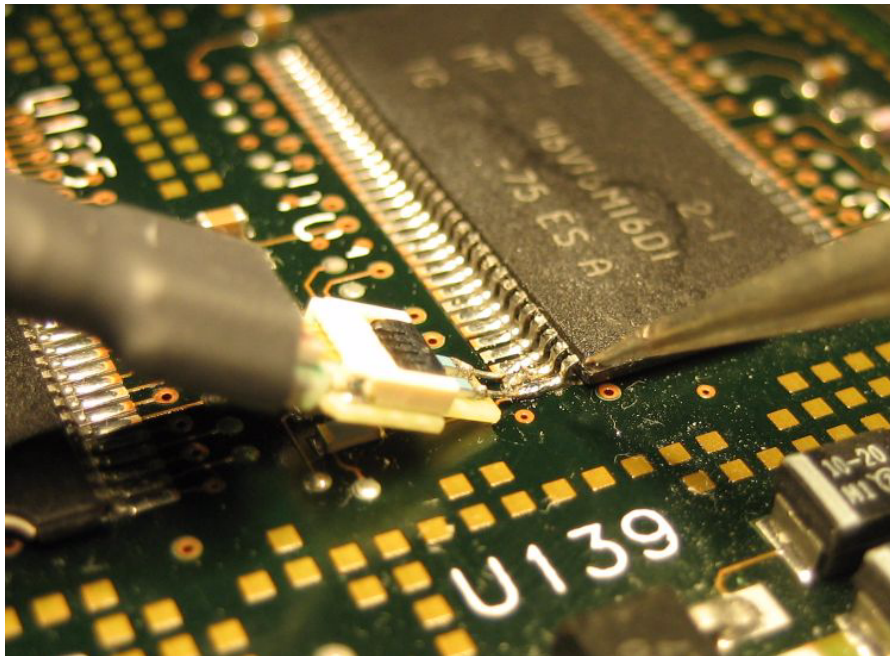

ZIF Tip Positioned and Soldered In Place

- 5 Remove ZIF Probe Head and leave ZIF Tip behind for future connection. It is best to use a non-conductive, pointed object such as a tooth pick or plastic tool. Hold on the heat-shrink part of the probe head to support the ZIF Tip while releasing the latch. Figure 1-42 shows a toothpick releasing the latch on the ZIF connector and Figure 1-43 shows the ZIF Tip left behind in the DUT with the latch open, ready for future connections.

Figure 1-42

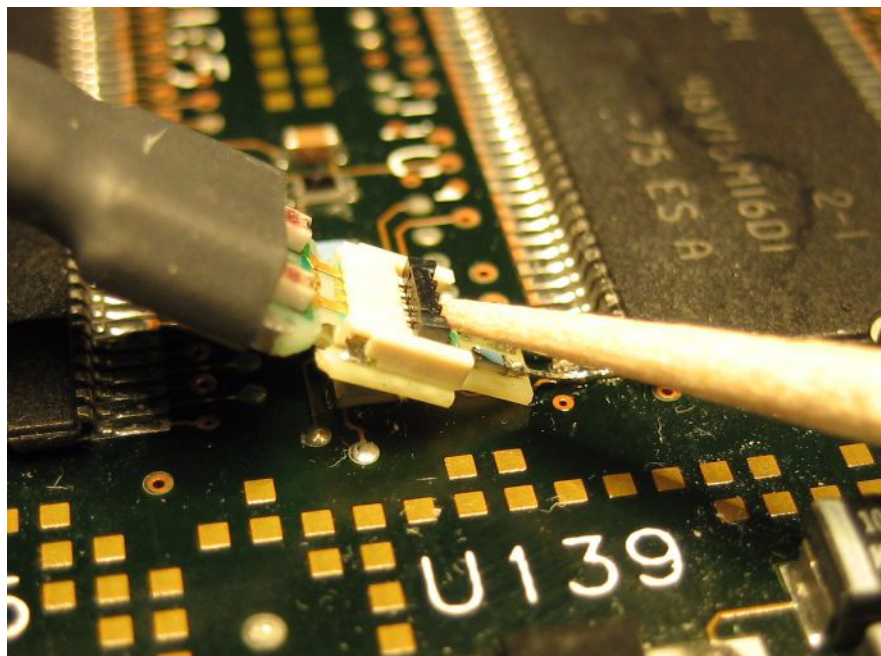

Using a Non-conductive Tool to Open the ZIF Connector

General Information
Procedures and Soldering Tips for Using InfiniiMax ZIF and Long Wired ZIF Probe Heads

Figure 1-43

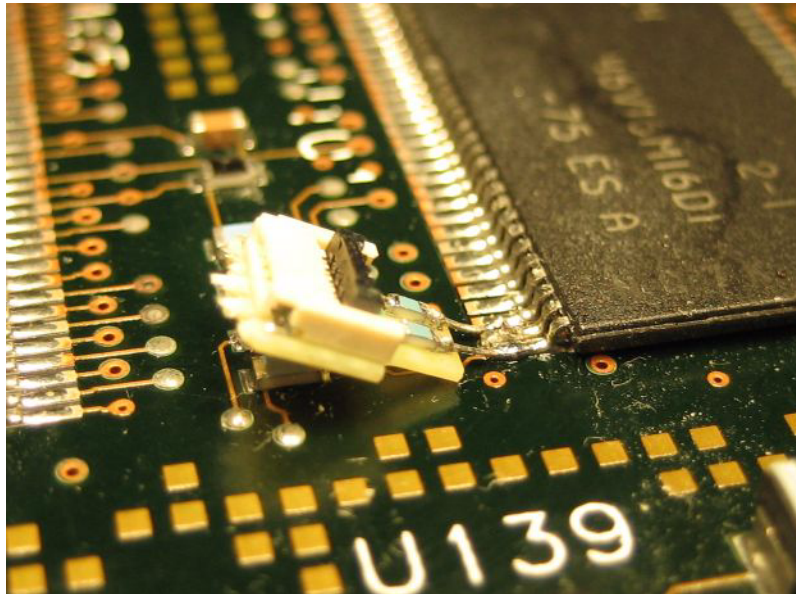

ZIF Tip Left Behind in DUT with ZIF Latch Open

- 6 Connect ZIF probe head to ZIF Tip desired for measurement. When you need to make a measurement at a point where you've previously installed a ZIF Tip, insure the latch on the ZIF Tip is open, insert the contacts on the probe head into the ZIF socket, and then close the ZIF latch with a non-conductive tool. Depending on the positioning of the ZIF Tip, you may need to support the body of the ZIF Tip while closing the latch. This can be done tweezers or other suitable tool by grabbing the pc board at the tip while the latch is being closed. If the circuit is live and there is concern about shorting anything out, use plastic or non-conductive tweezers. See Figure 1-44.

Figure 1-44

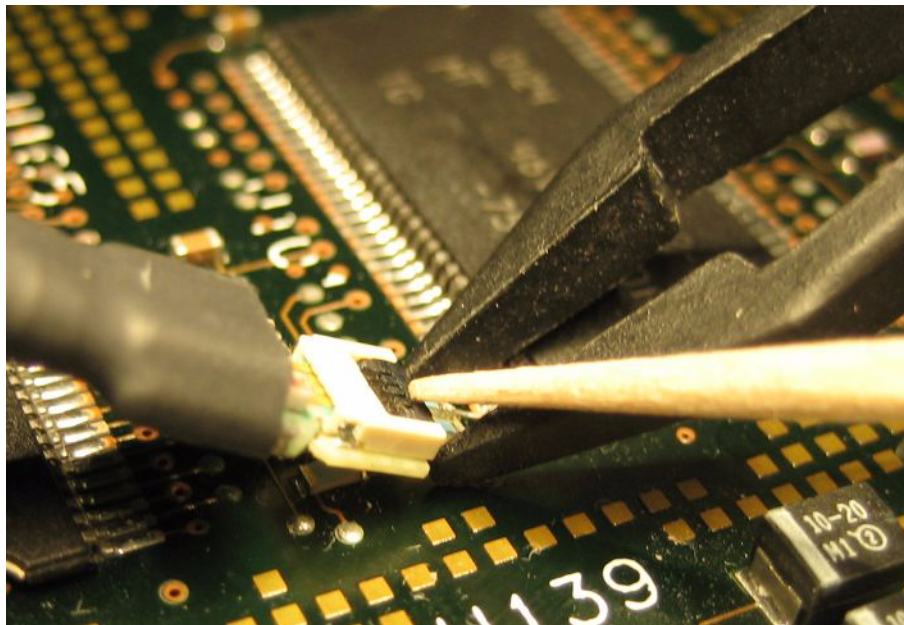

Use a Non-conductive Tool to Close the Latch

Using the N2887A / N2888A Soft Touch Probe Heads

The N2887A/N2888A InfiniiMax Soft touch probe heads adapt from the Agilent Pro Series Soft touch foot print to the GPO input connectors found on the Agilent InfiniiMax 1130A-1134A and 1168A/1169A Series probe amplifiers. This enables users to perform high density, multi-channel probing. Each adapter can support both the Soft touch single-ended and differential footprints and pin-outs.

The InfiniiMax Soft touch probe heads offer significant benefits in terms of reliability, ease-of-use, and space saving. The support of both single-ended and differential signals is achieved by either connecting a single-ended channel (one connector) into the “+” input of the InfiniiMax amplifier or by plugging the differential complements (2 connectors) into the appropriate “+” and “-” inputs of the Infiniimax amplifier. There exists a 1:1 mapping of Soft touch signal and clock lanes to InfiniiMax amplifier input GPO connectors - a total of 36 or 18 GPO connectors is necessary to support the possible configurations for N2887A and N2888A respectively.

The InfiniiMax Soft touch probe heads attach to the PC board using a retention module which ensures pin-to-pad alignment and holds the probe in place. A kit of five retention modules is shipped with each InfiniiMax Soft touch probe head. Additional kits can be ordered.

The probe heads also come pre-installed with protectors/cable organizers. The customer has the option of using these so the cables do not get tangled and to keep the metal ends of the connectors from shorting to the target.



Accessories / Replacement Parts

The following table lists the accessories / replacement parts.

Part Number	Description
E5405-68702	Retention Module Replacement kit for N2887A
E5396-68702	Retention Module Replacement kit for N2888A
N2887-60002	Deskew and Performance Verification Fixture

General Information

Using the N2887A / N2888A Soft Touch Probe Heads

Compatibility

The N2887A / N2888A probe heads are compatible with the following InfiniiMax probe amplifiers:

- 1130A
- 1131A
- 1132A
- 1134A
- 1168A
- 1169A

Characteristics

Characteristics for the N2887A / N2888A probe heads are shown below. The probe / oscilloscope should be warmed up for at least 20 minutes before any testing and the environmental conditions should not exceed the probe's specified limits.

Bandwidth (-3 dB)	4 GHz
Flatness	+/- 5%
Single-ended Equivalent Loading Capacitance	< 1 pF
Differential Equivalent Loading Capacitance	< 0.5 pF
Single-ended Input Impedance	25 k Ω
Differential Input Impedance	50 k Ω
Channel to Channel Coupling	< -35 dB to 1.7 GHz, < -20 dB to 4 GHz
Channel to Channel Skew	< 15 ps

all are typical

Probe Head Dimensions

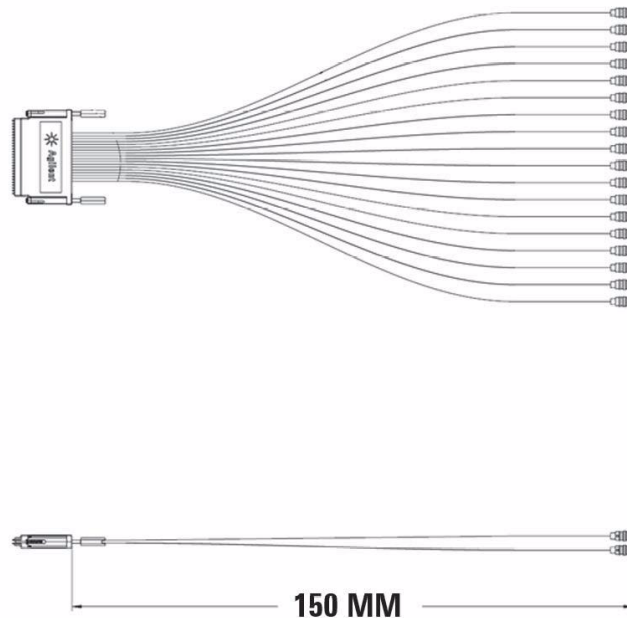

N2887A Footprint Dimensions

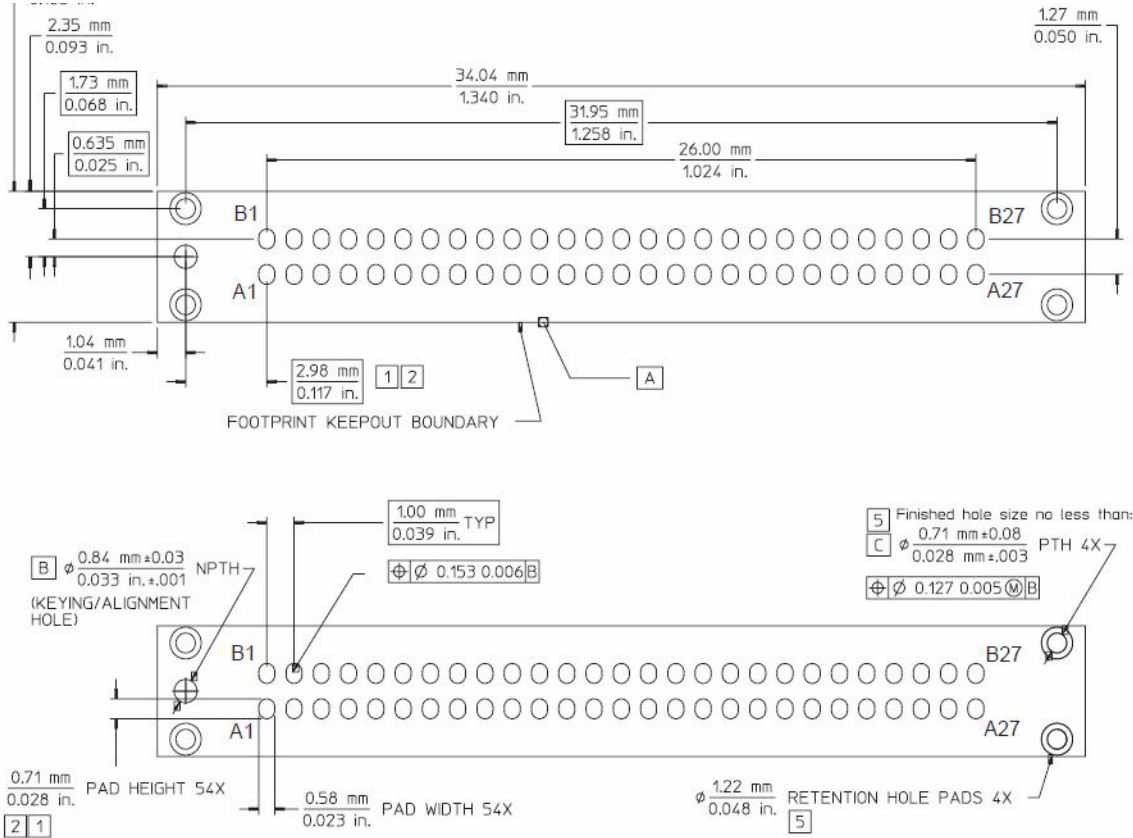

The above view is looking down onto the footprint on the printed circuit board.

NOTES (the following numbers correspond to the labels in the diagram above):

- 1 Must maintain a solder mask web between pads when traces are routed between the pads on the same layer. Solder mask may not encroach onto the pads within the pad dimension shown.
- 2 Via in pad not allowed on these pads. Via edges may be tangent to pad edges as long as solder mask web between vias and pads is maintained.
- 3 Permissible surface finishes on pad are HASL, immersion silver, or gold over nickel.
- 4 Footprint is compatible with retention model E5405-68702.
- 5 Plated through hole should not be tied to ground plane for thermal relief.

General Information
Using the N2887A / N2888A Soft Touch Probe Heads

N2888A Footprint Dimensions

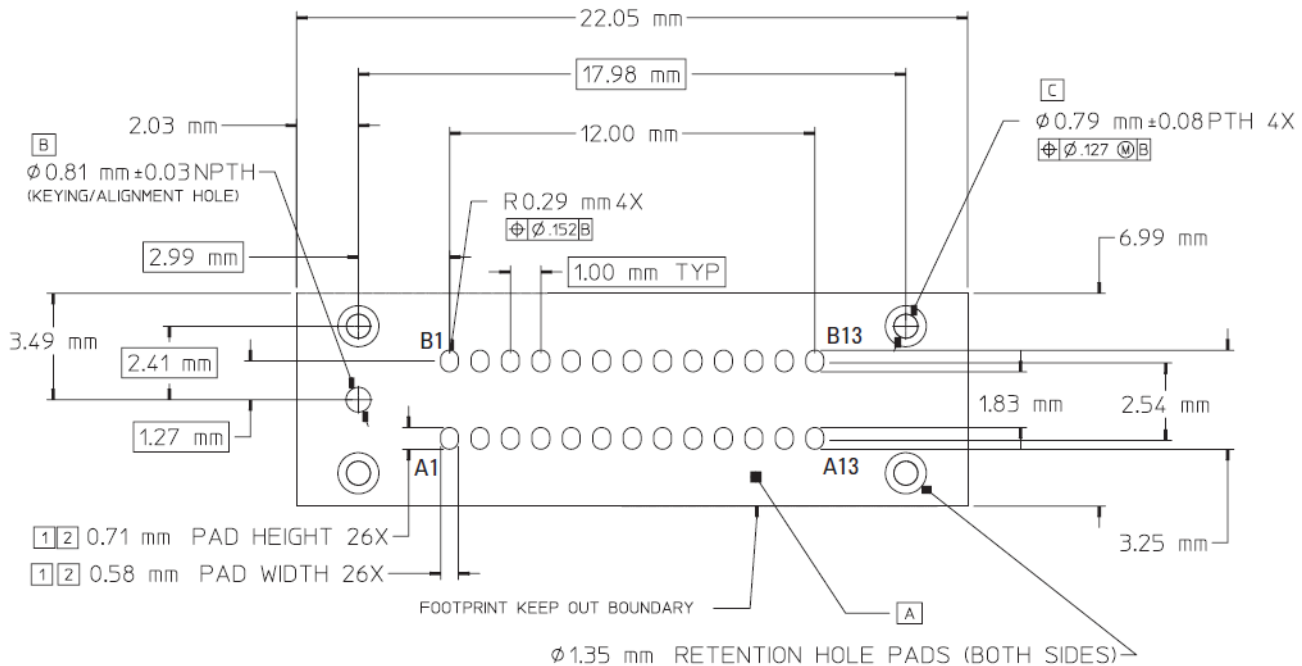

The above view is looking down onto the footprint on the printed circuit board.

NOTES (the following numbers correspond to the labels in the diagram above):

- 1 Must maintain a solder mask web between pads when traces are routed between the pads on the same layer. Solder mask may not encroach onto the pads within the pad dimension shown.
- 2 Via in pad not allowed on these pads. Via edges may be tangent to pad edges as long as solder mask web between vias and pads is maintained.
- 3 Permissible surface finishes on pad are HASL, immersion silver, or gold over nickel.
- 4 Footprint is compatible with retention model E5396-68702.
- 5 Retention module dimensions are 20.04 mm x 6.99 mm x 4.95 mm tall relative to the top surface of the PCB. Retention pins extend 27.18mm beyond the bottom surface of the RM through the PCB.

E5405-68702 Retention Module Dimensions

This retention module is compatible with the N2887A probe head. This retention module is Agilent specific and does not match any other vendor's connectors. The footprint of the probe head matches other vendors, but the retention modules do not match.

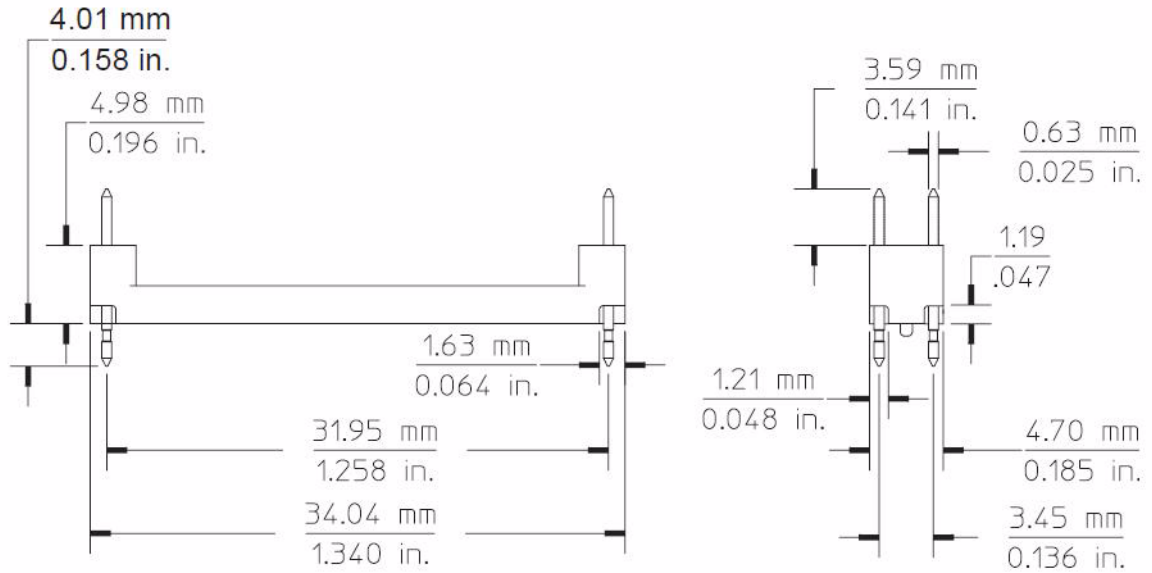

E5405-68702 Retention Module Dimensions

This retention module is compatible with the N2888A probe head. This retention module is Agilent specific and does not match any other vendor's connectors. The footprint of the probe head matches other vendors, but the retention modules do not match.

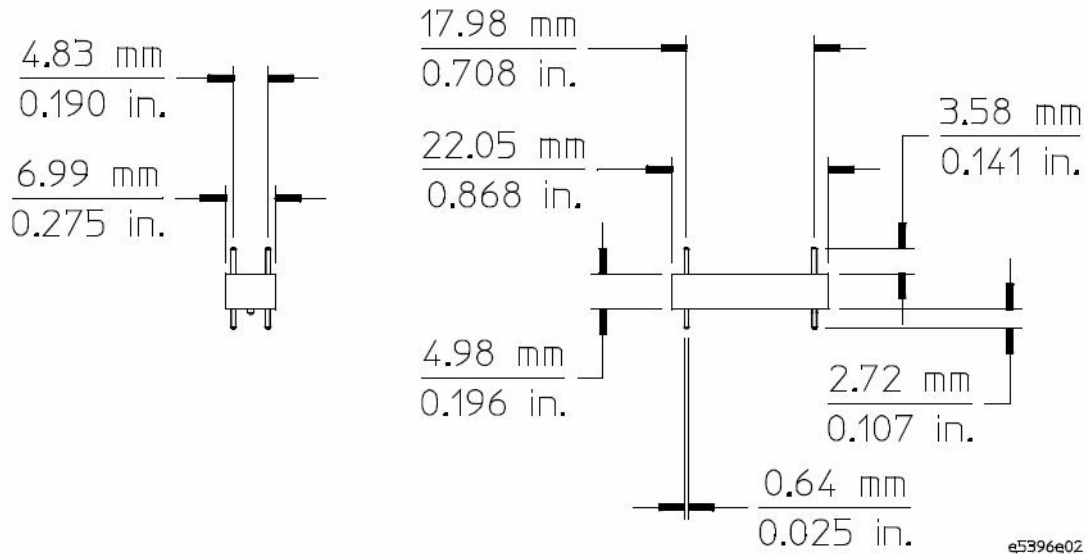

e5396e02

General Information

Using the N2887A / N2888A Soft Touch Probe Heads

N2887A / N2888A Plots

Plots for the N2887A/N2888A probe heads can be found on page 62.

When looking at these plots, it is important to define what “differential” and “single-ended” means for these probe heads. The following is a diagram of the differential and single-ended configurations:

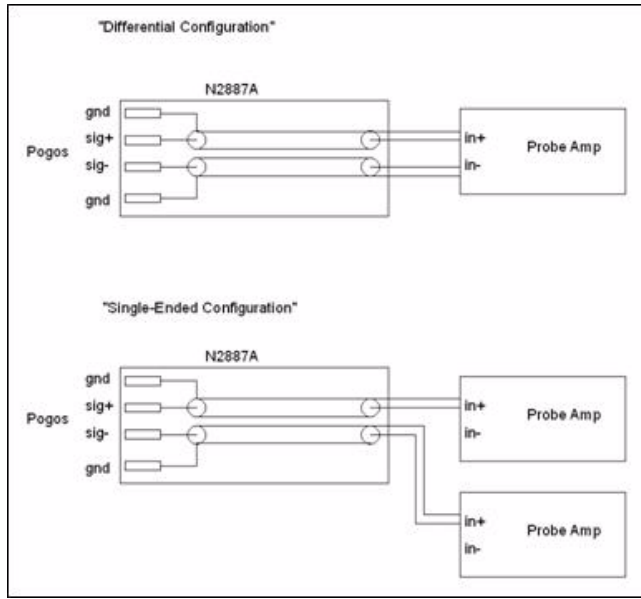

Note that the single-ended configuration is not a differential probe probing a single-ended signal, but rather is a single-ended probe probing a single-ended signal.

Pin-outs

The N2887A probe head contains 36 single connections and 18 dedicated ground connections. The arrangement of signals (differential, single-ended, clocks) is definable by the user. The signal and ground connections of the N2887A are arranged so they are compatible with the Agilent Pro Series Soft Touch logic probe footprint (E5402A, E5404A, E5405A, and E5406A). When probing an existing Pro Series Soft Touch footprint, refer to the *Agilent E5400-Pro Series Soft Touch Connectorless Probes User's Guide* for specifics about signal and clock locations.

N2887A Soft Touch Pro-to-InfiniiMax Adapter Pin-Out

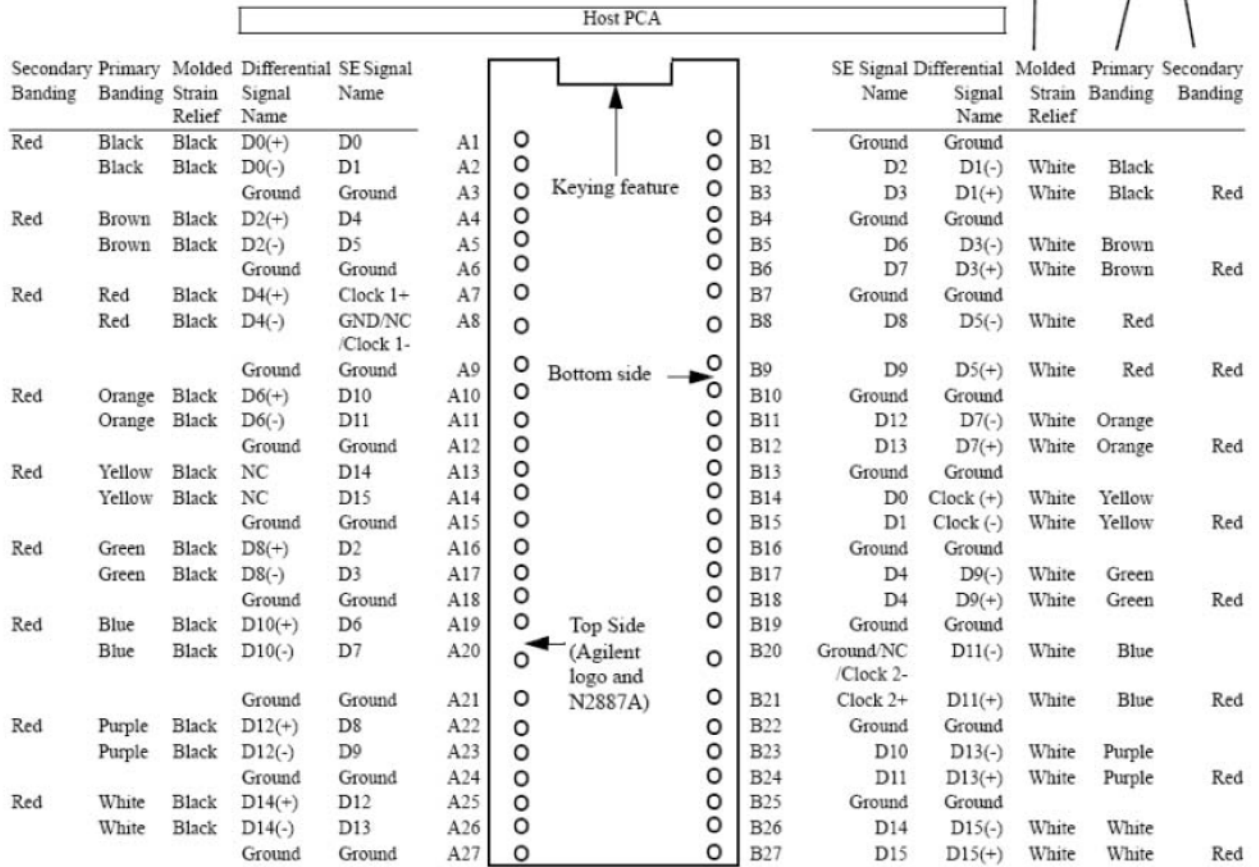

General Information
Using the N2887A / N2888A Soft Touch Probe Heads

The N2888A Half-Channel probe head contains 18 single connections and 8 dedicated ground connections. The arrangement of signals (differential, single-ended, clocks) is definable by the user. The signal and ground connections of the N2887A are arranged so they are compatible with the Agilent Half-Channel Series Soft Touch logic probe footprint (E5396A and E5398A). When probing an existing Half-Channel Series Soft Touch footprint, refer to the *Agilent E5400-Pro Series Soft Touch Connectorless Probes User's Guide* for specifics about signal and clock locations.

N2888A Soft Touch Half Channel-to-InfiniiMax Adapter Pin-Out

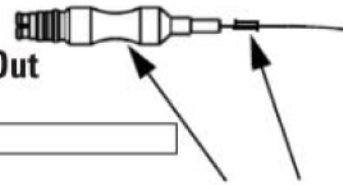

Primary Banding	Molded Strain Relief	Differential Signal Name	SE Signal Name				SE Signal Name	Differential Signal Name	Molded Strain Relief	Primary Banding	
Black	Black	D0(-)	D1	A1	○		B1	D0	D0(+)	White	Black
Brown	Black	D1(-)	D3	A2	○	Keying feature	B2	D2	D1(+)	White	Brown
		Ground	Ground	A3	○		B3	Ground	Ground		
Red	Black	D2(-)	D5	A4	○		B4	D4	D2(+)	White	Red
Orange	Black	D3(-)	D7	A5	○	Bottom side ("key")	B5	D6	D3(+)	White	Orange
		Ground	Ground	A6	○		B6	Ground	Ground		
Yellow	Black	D4(-)	D9	A7	○		B7	D8	D4(+)	White	Yellow
Green	Black	D5(-)	D11	A8	○	Top Side (N2888A model number listed)	B8	D10	D5(+)	White	Green
		Ground	Ground	A9	○		B9	Ground	Ground		
Blue	Black	D6(-)	D13	A10	○		B10	D12	D6(+)	White	Blue
Purple	Black	D7(-)	D15	A11	○		B11	D14	D7(+)	White	Purple
		Ground	Ground	A12	○		B12	Ground	Ground		
White	Black	???	NC	A13	○		B13	Clock	???	White	White

N2887A/N2888A Calibration and Deskew Procedure

The N2887-60002 Calibration/Deskew kit contains the following parts:

- SMA (male) to SMA (male) adapter
- SMA (male) to BNC (female) adapter
- BNC (male) to SMA (male) adapter
- 50 Ω Terminator
- Deskew Fixture



Calibration of the N2887A/N2888A probe heads consists of a vertical calibration and a skew calibration. The vertical calibration should be performed before the skew calibration. Both calibrations should be performed for best probe measurement performance.

NOTE: Before calibrating the probe, verify that the Infiniium oscilloscope has been recently calibrated and that the calibration change in temperature is ± 5 °C. If this is not the case, calibrate the oscilloscope before calibrating the probe. This information is found in the Infiniium Calibration dialog box.

Connecting the Probe for Calibration

The calibration procedure requires the following parts:

- BNC (male) to SMA (male) adapter
- Deskew fixture
- 50 Ω SMA terminator

- 1 Connect the BNC (male) to SMA (male) adapter to the deskew fixture on the connector (it does not matter which connector you use).
- 2 Connect the 50 Ω SMA terminator to the other connector on the deskew fixture.
- 3 Connect the BNC side of the deskew fixture to the Cal Out BNC on the Infiniium oscilloscope.
- 4 Connect either the N2887A or N2888A probe head to the deskew fixture as shown in the figure on the following page (note: use the appropriate connector for either the N2887A or N2888A model as shown on the following page).

General Information
Using the N2887A / N2888A Soft Touch Probe Heads

5 Connect the InfiniiMax probe amp to an oscilloscope channel.

Connect one of the leads from the probe head to the positive terminal on the InfiniiMax probe amplifier. The lead you will use depends on whether you are using the N2887A or N2888A probe head.

For the N2887A probe head, use the connection with the white molded strain relief and the yellow primary banding (see diagram on the next page).

For the N2888A probe head, use the connection with the black molded strain relief and yellow primary banding (see diagram below).

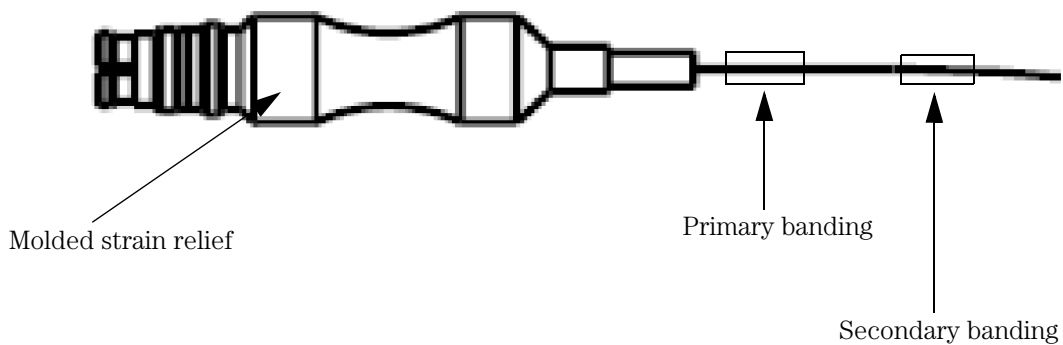

NOTE: To minimize the wear and tear on the probe head, the probe head should be placed on a support to relieve the strain on the probe head cables.

NOTE: Please note that you are only deskewing one channel on the InfiniiMax Soft Touch probe head in this procedure. The other channels are nominally identical (< 15 ps). The major source of skew when using multiple InfiniiMax amplifiers with a single InfiniiMax Soft Touch probe head is the variations from one amplifier to another. This skew can be addressed by repeating the procedure outlined above for each InfiniiMax amplifier that will be used.

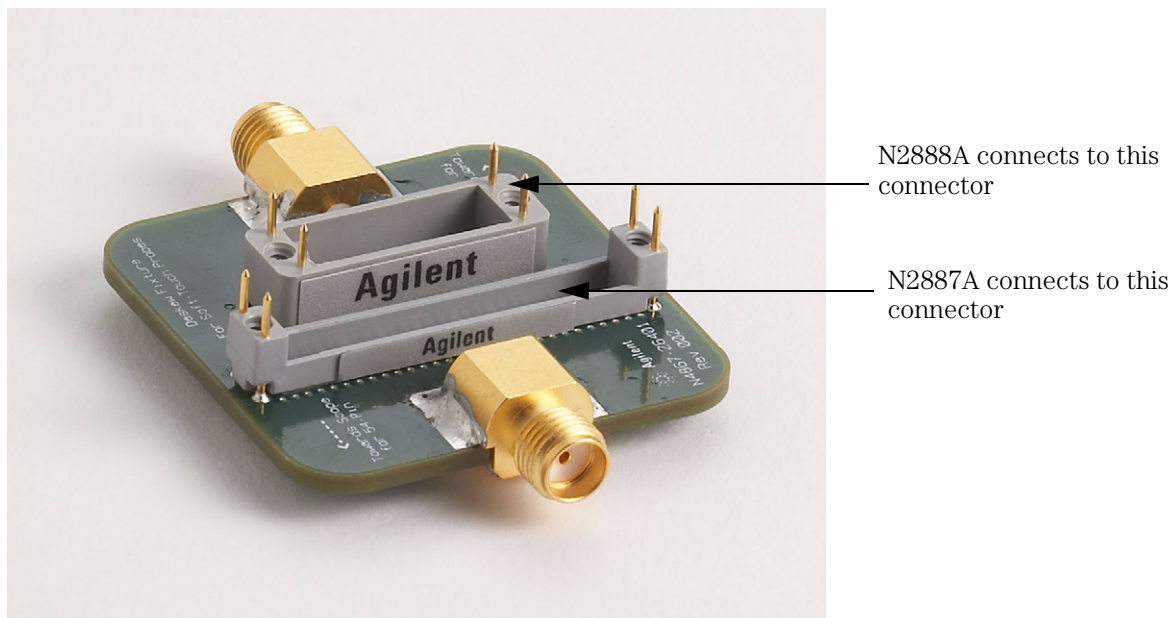

Once you have the probe head connected correctly, perform a normal probe calibration as described in the Infiniium help system available on the oscilloscope.

General Information
Using the N2884A InfiniiMax Fine Wire ZIF Tips

Using the N2884A InfiniiMax Fine Wire ZIF Tips

The N2884A InfiniiMax Fine Wire ZIF tips are similar to the standard N5425A InfiniiMax ZIF tips except they are equipped with 22 micron tungsten wires. These wires are extremely small and difficult to see. Therefore, a high-powered microscope will be required for many of the processes described below. Please also note that it is important to handle these Fine Wire ZIF tips carefully as the thin wires can be easily damaged. **PLEASE CONSULT THE LIST OF WARNINGS ON THE NEXT PAGE TO KEEP FROM PERMANENTLY DAMAGING THE WIRES.**

The response plots for the N2884A Fine Wire ZIF tips are substantially the same as the plots for the N5425A standard ZIF tip (see Chapter 2, page 31). The only major difference is that the bandwidth for the N2884A (with the 1169A probe amplifier) is slightly less than for the N5425A (12 GHz versus 12.3 GHz). The bandwidth when the N2884A is used with the 1134A probe amplifier is approximately 8 GHz. Use the SPICE model for the N5425A to model the input loading for the N2884A.

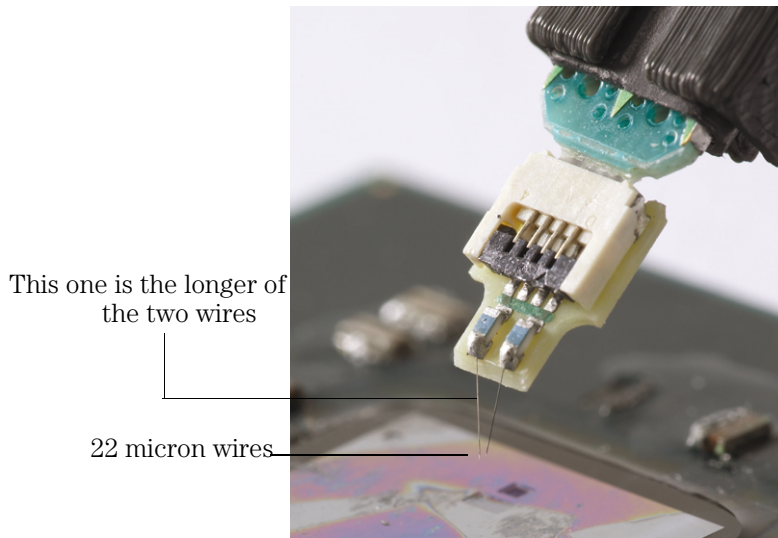

The N2884A kit comes with five Fine Wire ZIF tips and one positioner arm/thumb nut (to mount the probe head to a micropositioner).

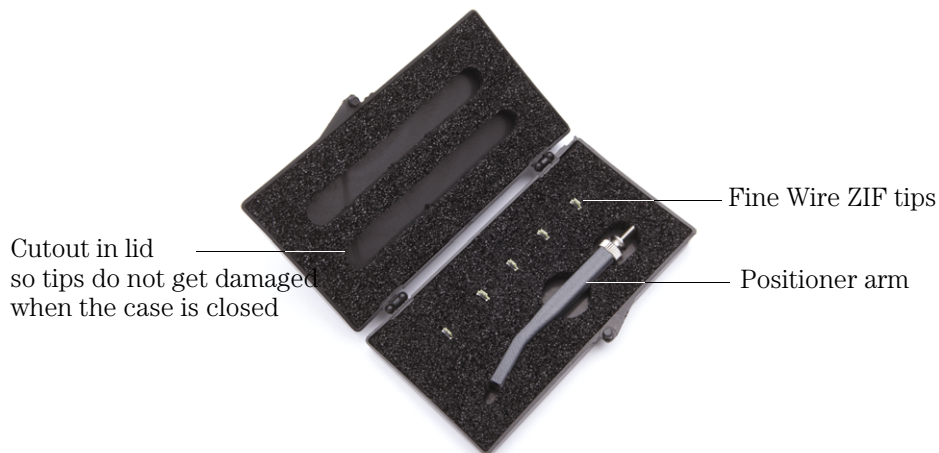

WARNINGS

- Be very careful with the 22 micron tungsten wires as they are very easily damaged.
- It is very difficult to see the thin wires. Do not assume that they are not attached to the tip simply because you cannot see them at first glance.
- When removing the tips from the packaging, use flat nose tweezers and grab the tip by the pc board (as described in Step 6). Do not ever grab the tip by the wires.
- Once the tip is attached to the ZIF probe head, make sure the latch described in Step 7 is placed in the closed / locked position to secure the connection.
- Make sure the micropositioner is secured to something metallic (its base is magnetic) as it is nose-heavy. If it is left resting on a surface that the metallic base cannot secure to, it will tip over and the Fine Wire ZIF tip may become damaged.
- When placing the Fine Wire ZIF tips back into the case, please ensure that the tips are pointing directly up. There are cutouts in the top of the case that give space for these wires when the case is closed. However, if the tips are not pointing directly up, they may miss these cutouts and become damaged.
- When the Fine Wire ZIF tip is positioned under a microscope, be very careful with the lenses of the microscope as you adjust the magnification or focus. If one of the lenses strikes the tip, it could permanently damage it.
- The two wires can come into contact during probing if you are not careful in preventing it. There are two ways this can happen. (1) If you set the longer wire and then try to probe a position with the short wire that forces their tips to cross, the two wires can touch. (2) When you set the wires, they will buckle. The wires may not be touching at their tips in this case (so they would look fine under a microscope), but the buckling could cause them to touch each other near their mid-points. Therefore, it is always a good idea to decrease the amount of magnification so you can see the entire wire lengths and make sure they are not in contact. Only turn on the device under test (DUT) when you have verified that the wires are not touching.

Step-by-Step Procedure For Using the Fine Wire ZIF Tips

The procedure required to use these tips is very specific and will be described below. Please read the instructions carefully as each step alerts you to common problem areas and things you need to be aware of when using this tip.

Step 1: Calibrate the Probe

If you have not recently calibrated the probe or if this is the first time you have ever used this probe amplifier/head/tip combination on the specific oscilloscope channel you plan on using, you should calibrate the probe. The best and easiest way to calibrate this probe setup is to use the standard N5425A ZIF tips rather than the Fine Wire ZIF tips (since they are very similar in their electrical response characteristics and it is much easier to quickly work with the N5425A standard ZIF tip).

Therefore, use the N5425A probe head and tip (along with an InfiniiMax probe amplifier) and calibrate the probe as you typically would. Then disconnect the tip and head and proceed to the next step.

Step 2: Place the ZIF Probe Head (N5425A) Into the Positioner

Arm

The positioner arm is located inside the case with the five Fine Wire ZIF tips (refer to page 64 to see where it is located in the case). Remove it from the case and insert the N5425A ZIF probe head into it as the diagram shows below (the Fine Wire ZIF tip should not be connected to the N5425A ZIF probe head yet).

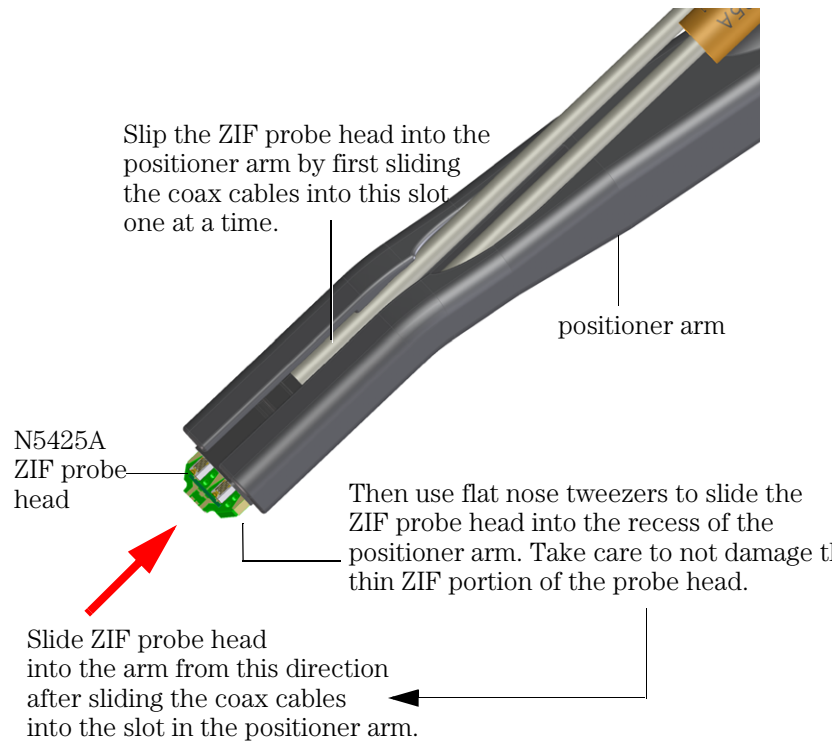

Step 3: Install the Positioner Arm Into the Micropositioner

Secure the positioner arm to the micropositioner using the thumb nut as shown in the picture below. Agilent recommends using the Wentworth Laboratories micropositioner shown in the picture. You can either order it directly from Wentworth Laboratories (www.wentworthlabs.com) or you can order it from Agilent. If you order it through Agilent, you must order the following two parts (**you must order them both**):

- N2884-64702 (Wentworth 2026-90409 PVX 400-M: Manual Linear Manipulator Magnetic Base)
- N2884-64703 (Wentworth 5-00-4711 Short Nose Articulated Short Arm Front)

While Agilent recommends using the Wentworth micropositioner shown below, the Fine Wire ZIF positioner arm is compatible with many micropositioners as long as the thumb nut has enough

General Information

Using the N2884A InfiniiMax Fine Wire ZIF Tips

threads to firmly secure the positioner arm.

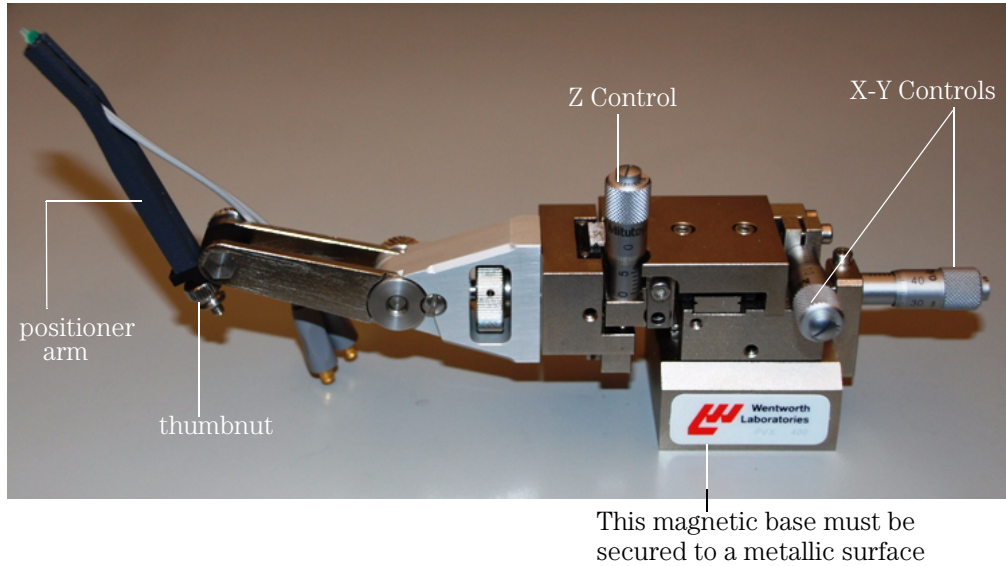

Step 4: Secure the Micropositioner

When the Fine Wire ZIF tips are attached to the probe head, it is important that the micropositioner is properly secured. It is nose-heavy so if the surface it is on does not allow its magnetic base to secure it, the micropositioner will tip over and damage the ZIF tip. Therefore, you need to place the micropositioner on a metallic surface and ensure that its metallic base is indeed secured so it will not tip over.

Step 5: Attach the Probe Head to Probe Amplifier

Once the Fine Wire ZIF tip is attached to the probe head, it will be extremely important that you are careful with the entire setup (so you do not crush or damage the wires). Therefore, it is usually easiest to connect the probe head to the InfiniiMax probe amplifier before you attach the Fine Wire ZIF tips. You can also connect the probe amplifier to the oscilloscope at this time.

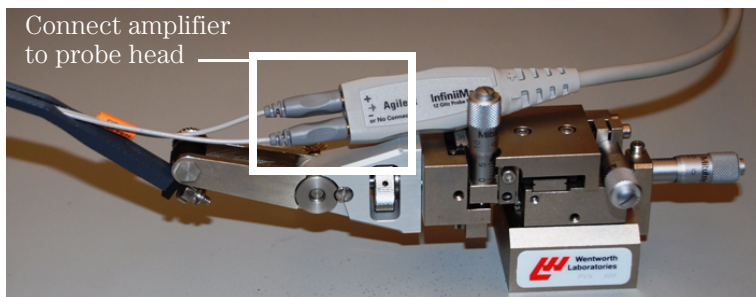

Step 6: Remove a Fine Wire ZIF Tip From the Case

The picture below shows the five Fine Wire ZIF tips that are included in the case. It is difficult to see, but each tip has its wires pointing directly up. This is because there is a cutout in the case's lid that allows for these wires to not be bent when the lid is closed. If the wires are not pointed directly upward, they could become damaged when the lid is closed.

To remove a tip from the packaging, grasp the pc board of the tip with flat nose tweezers (as shown below) and lift directly out of the foam. Do not ever lift the tip out by grasping the wires.

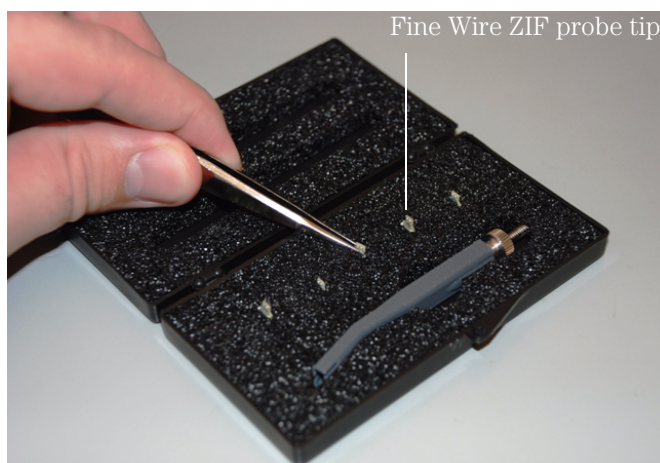

Step 7: Attach the ZIF Probe Head to the Fine Wire ZIF Tip

While still grasping the tip with flat nose tweezers, use another set of tweezers to lift the latch to the open position (the open position is shown in the picture below). Again, be very careful not to hit the wires. The picture below shows the standard ZIF tip and is only meant to highlight the latch's open position (the latch is the same on the standard and Fine Wire ZIF tips).

General Information
Using the N2884A InfiniiMax Fine Wire ZIF Tips

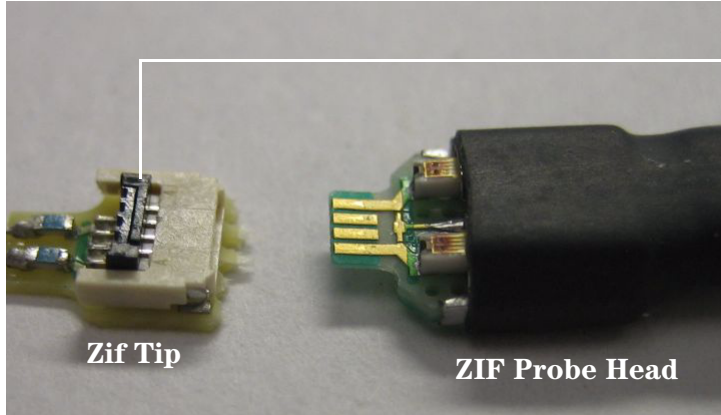

This is what the latch looks like when it is in the open position

The probe head should already be attached to the positioner arm (which is secured to the micropositioner). Push the Fine Wire ZIF tip onto the probe head and close the latch to lock them together. Again, the picture below does not show the probe head inside the positioner arm. It is meant to show you what the latch looks like when it is closed.

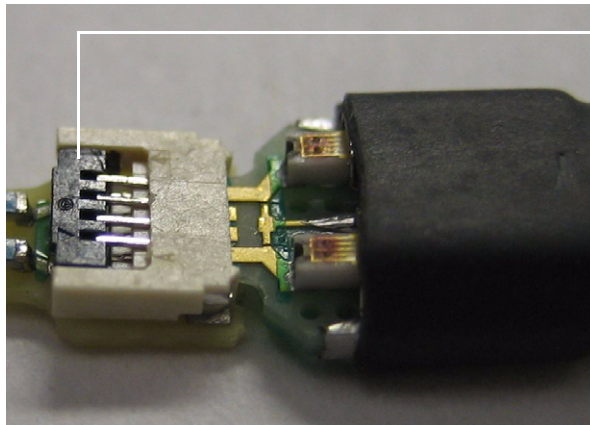

This is what the latch looks like when it is in the closed position

Your setup is now complete and you are ready to begin probing. The next steps will give you hints on how to probe using this tip.

Step 8: Attach the Fine Wire ZIF Tip Onto the Board

The procedure described below is for probing the underside of ICs and describes a specific use-scenario. There may be other possible ways to use this probe tip.

The following steps require a probing station and a high-powered microscope.

DO NOT TURN ON YOUR DEVICE UNDER TEST (DUT) UNTIL YOU HAVE LANDED BOTH WIRES AND CONFIRMED THEY ARE NOT TOUCHING (as described below).

In order to prepare the IC for probing, you first need to chemically etch a large trench out of the IC. Within the trench, create at least two wells (target well and ground well) to the targeted metal layers. These wells should be approximately 15x15 microns and 10 microns deep. These wells keep the probe tip from "skating" across the surface as they give a place for the wires to anchor. You may need to create many wells depending on the number of targets you want to probe, but you at least need two in order to have a ground well and a target well. A small amount of tungsten should be placed in the bottom of each well. The maximum distance between wells is 600 microns.

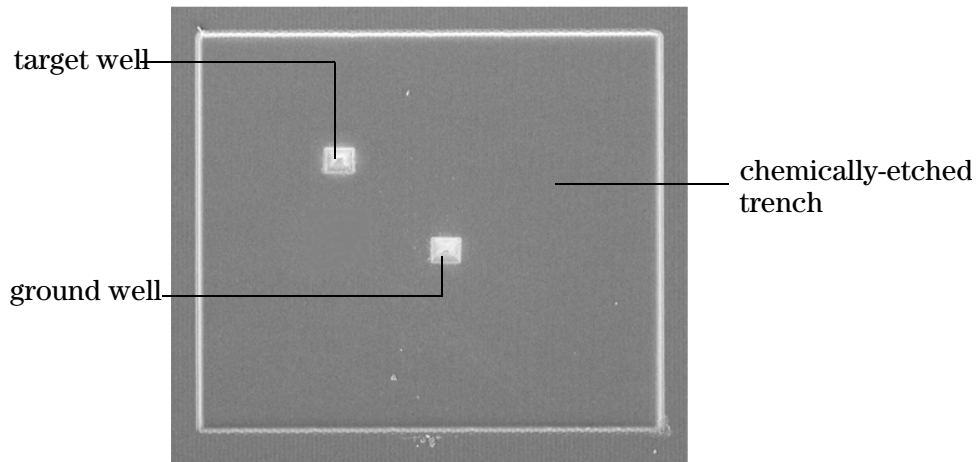

The image above shows an example of the trench and two wells under magnification.

The two 22 micron wires on the Fine Wire ZIF tip are of different lengths. The longer wire will be driven down first to set the z-axis and then you will land the short wire. It does not matter which wire goes into the ground well and which goes into the target well, but it does matter that the longer wire is set first.

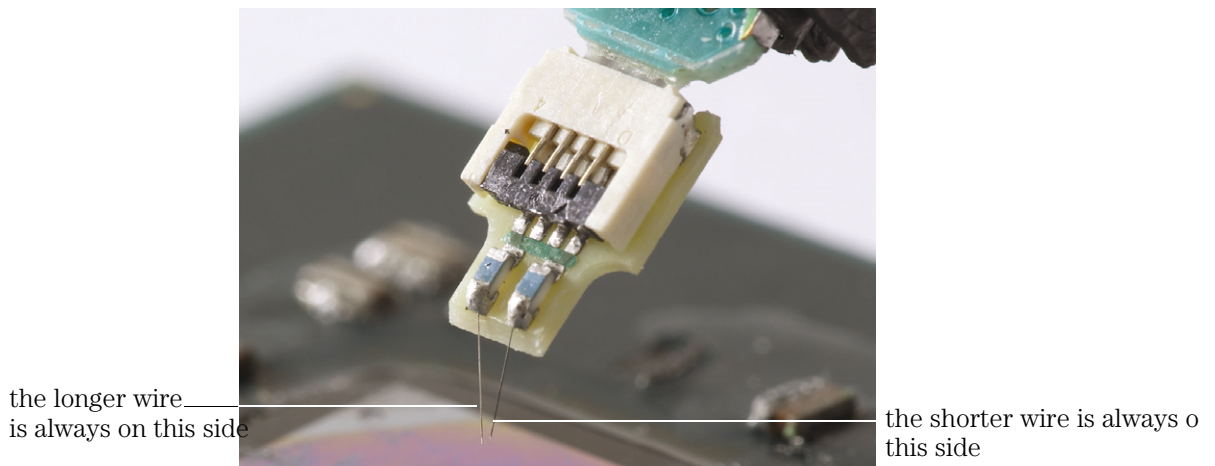

It also matters how the two wells are positioned relative to each other. Look at the following diagram:

General Information

Using the N2884A InfiniiMax Fine Wire ZIF Tips

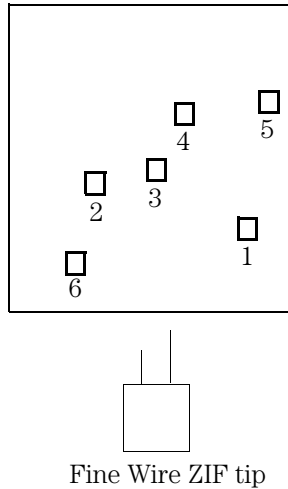

When you land the longer wire first, you will want to land it in a well that is below and to the right (from the perspective of the probing direction) relative to the wells in which you are going to land the short wire. In the diagram above, you could land the longer wire in well 1 and then probe locations 2, 3, and 4 with the short wire. You could not, however, reach well 5 with the short wire (the two wires could cross, shorting them in the process). You also could not reach well 6 with the short wire due to the configurations of the wire (this will cause an upward bend in the wires that could be detrimental to the probing performance). The short wire wells will always need to be up and to the left of the long wire well (from the perspective of the probing direction).

To land both of the wires in the wells, first position the IC under a microscope and move both wires into the region as shown below.

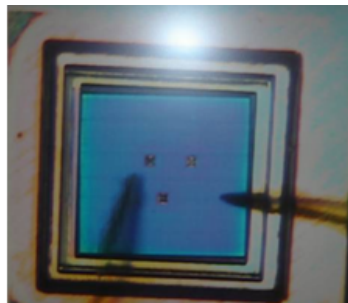

The two pointed shadows shown in the image to the left are the 22 micron wires

How easy the rest of these steps are will depend on how powerful of a microscope you have. It may take a while to get adjusted to the process, but with some practice, you should grow in your comfort level.

Move the positioner in the x-y direction until the tip of the long wire is above its well. You may not be able to see the wells and the wires in focus at the same time. If this is the case then first focus on the wells and then slowly move the focus out until you can see just the tips of the wires. You should then be able to move the longer wire tip over the first well.

Next, slowly land the tip in its well (using the z-direction adjustment on the micropositioner). Keep moving down until you see the end of the wire bend slightly. This will ensure that this wire remains stuck while we translate the shorter wire in the next step. Do not land the longer wire too hard or you could damage it. Once you see it flex, stop moving in the z-direction and use the x-y knobs on the micropositioner to wiggle the longer wire slightly. If the wire wiggles, but stays

stuck in place on the IC then it was properly placed in the well.

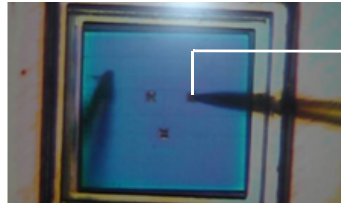

Land the longer of the two wires in its well

With the longer wire in place, move the micropositioner in the x-y direction until the shorter wire is over the target well. Then adjust the positioner in the z-direction to land the shorter wire into its well.

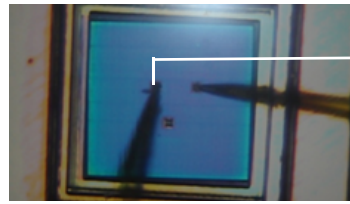

Land the shorter of the two wires into its well

The Fine Wire ZIF tip should now be ready to make a differential measurement. Before turning on your device under test (DUT), you need to ensure that the two wires are not touching. You should be able to confirm in the microscope that the tips are not overlapping, but these wires do buckle when you land them so they could be touching further up the wires. Decrease the magnification of the microscope until you can see the entire length of both wires and ensure that the wires are not touching.

Step 9: Configuring the Correct Settings on Your Oscilloscope

You should select the N5425A probe head in the probe menu on your oscilloscope when using the Fine Wire ZIF tip. You are now ready to acquire a signal.

General Information
Using the Extreme Temperature Cable Extension Kit (N5450A)

Using the Extreme Temperature Cable Extension Kit (N5450A)

The Extreme Temperature Cable Extension kit allows users to use an oscilloscope probe to monitor a system in a temperature chamber. This may be done to verify performance over a wide range of temperatures or to determine the cause of failure at high or low temperatures. Agilent's Infiniimax probe amplifiers have a specified operating temperature range from 5° C to 40° C, but the probe heads can be operated over a much larger range of temperatures. The N5450A extension cables can be used to physically separate the amplifier from the probe head to allow the user to operate the probe head inside a temperature chamber while the probe amplifier remains outside the chamber. The cables can be seen below in figure 1-45.

Figure 1-45



The temperature ranges that can be probed depend upon the configuration of the probe head.

Probe Head Configuration ¹	Temperature Range (°C)	Average Lifetime of the Probe Head (cycles) ²
N5381A	-55 to +150	> 250
E2677A, E2678A, N5426A, or N5451A	-25 to +80	> 1000

¹Refers to the probe head or tip that is attached to the cable extension kit

²A cycle is defined to be a temperature sweep from either -55° C to 150° C and then back to -55° C or from -25° C to 80° C and then back to -25° C depending upon the probe head configuration being used

It is recommended that users keep their extreme temperature testing probes separate from the probes they use under milder conditions. This is because cycling probe heads through extreme temperature ranges has a marked affect on their lifetimes (refer to the table above for the average lifetimes of various probe heads/tips). It is important to note that only the lifetime of the probe head is affected by temperature cycling. The extension cables and probe amplifier should not need to be replaced with extended temperature cycling.

Rapid changes in temperature can also lead to moisture accumulating in the form of condensation on the probe components, as well as the DUT. If this occurs, the user should wait until the moisture has

evaporated before making any measurements.

To ensure a high-quality measurement, the N5450A cable set have been phase-matched at the factory. A coupling tag is included with the cables to ensure the cables stay as a matched pair. To install the coupling tag, slip the small end of each cable through the holes in the tag. The tag can be positioned anywhere along the length of the cable and can withstand the temperature ranges specified.

Additional care must be taken when handling probe heads used during extreme temperature cycling because this process makes the probe heads less robust. Agilent recommends that users secure the ends of the extension cable near the probe head to a secure location in their temperature chamber such that the probe head legs are not tugged or moved around significantly. Also, do not rest the extension cables on any metal objects or objects with sharp edges. This will prevent abrasion and tears in the jacket. The cables are designed to be flexible, but are not designed to be bent sharply. To prevent cable failure, do not kink the cables.

Discoloration or texture changes are possible with the extension cables. These changes do not, however, affect the performance or the quality of a measurement.

General Information
Using the N5380-64701 SMA Head Support

Using the N5380-64701 SMA Head Support

The Agilent N5380-64701 SMA Head Support is included with the N5380A and E2695A SMA probe heads to prevent damage to the probe amplifier. It is strongly recommended that you use the SMA Head Support whenever you are using either of these probe heads.

Below is a drawing showing how to attach the SMA Head Support using two of the four screws provided in the kit (the other two screws are extras in case you need them in the future). Be sure to plug the probe amplifier into the SMA head before installing the SMA Head Support. Also, do not attempt to plug or unplug the SMA head from the probe amplifier while it is in the SMA Head Support housing.

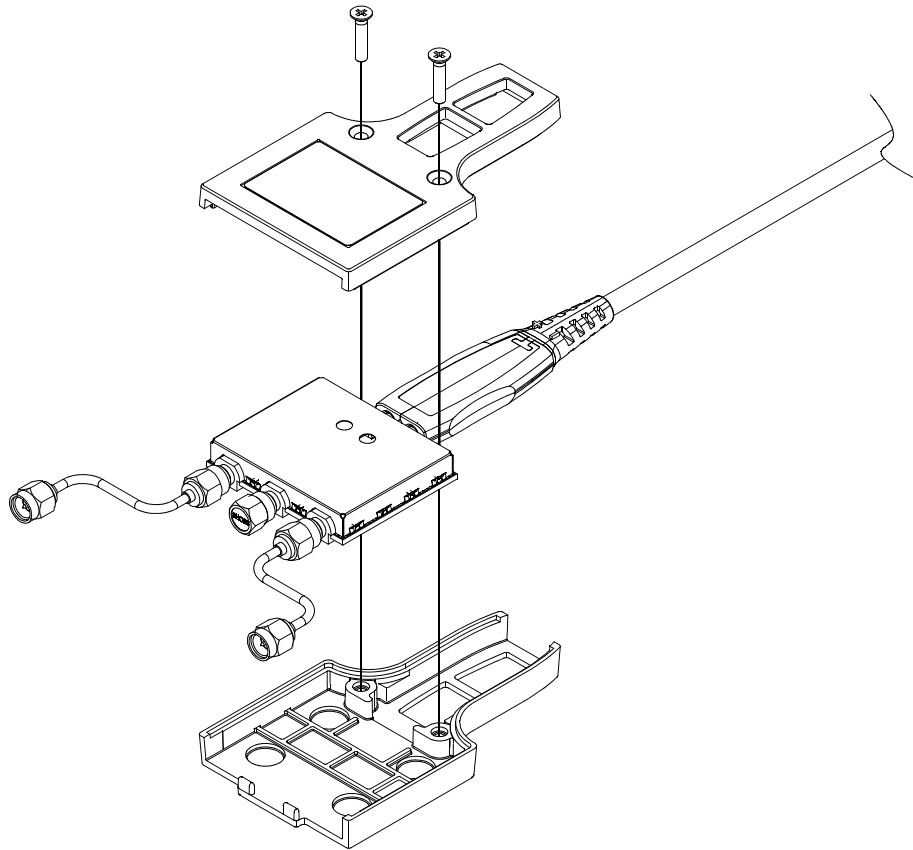

Using the N2880A InfiniiMax In-Line Attenuator Kit

The dynamic ranges of the InfiniiMax 1130A Series and the InfiniiMax 1168A/1169A Series are $5 V_{p-p}$ and $3.3 V_{p-p}$ respectively. If you need to measure larger signals, the architecture of the InfiniiMax probes allows you to add the N2880A InfiniiMax In-Line Attenuators between the probe head and the probe amplifier to increase the dynamic range (see picture below). Additionally, these attenuators enable you to increase the offset range of the probe (see the table below). When using the N2880A In-Line Attenuators, the bandwidth and rise time of your probing system is not affected. There is, however, a trade-off in noise (see table below) and in the accuracy of DC offset relative to the input.

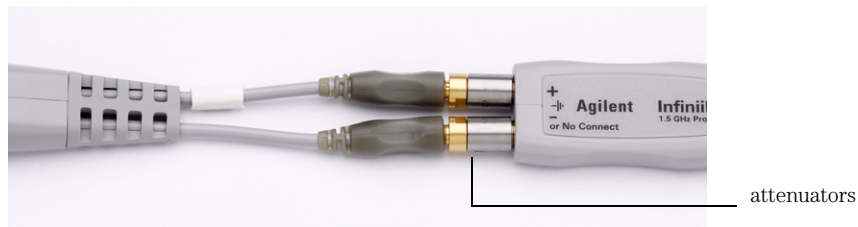

The maximum input voltage of the InfiniiMax probe heads is ± 30 Vdc, so they should not be used to measure signals that exceed this range. This places a practical limit of 20 dB on the attenuators used with the InfiniiMax probing system. Larger attenuation ratios will only degrade the noise performance and gain of the system.

The N2880A kit consists of 3 pairs of attenuators (6 dB, 12 dB, and 20 dB). These attenuators come as matched pairs and should only be used with each other. If you look on each attenuator, you will see a serial number. The pair of matching attenuators in each set will have the same four digit numeric prefix and will differ by the last letter (one attenuator in the matched pair will be labeled A and the other will be labeled B).

All InfiniiMax probe heads and amplifiers are compatible with the N2880A In-Line Attenuators. However, due to the N5380A dual-SMA probe head's maximum input voltage specification of 2.28 VRMS, the N5380A is not suitable for measuring signals large enough to require an added attenuator.

InfiniiMax Probe Amplifier	Added Attenuator	Dynamic Range	Offset Range	Typical Noise Referred to	Maximum Allowed Input Slew Rate** (se = single-ended) (diff = differential)	Nominal DC Attenuation of Probe System
1130A Series	None	5 Vp-p	± 12 V	3 mV RMS	se: 18 V/ns, diff: 30 V/ns	10:1
1130A Series	6 dB (2:1)	10 Vp-p	± 24 V	7.8 mV RMS	se: 36 V/ns, diff: 60 V/ns	20:1
1130A Series	12 dB (4:1)	20 Vp-p	± 30 V*	16.7 mV RMS	se: 72 V/ns, diff: 120 V/ns	40:1
1130A Series	20 dB (10:1)	50 Vp-p	± 30 V*	41.7 mV RMS	se: 180 V/ns, diff: 300 V/ns	100:1
1168A/1169A	None	3.3 Vp-p	± 16 V	2.2 mV RMS	se: 25 V/ns, diff: 40 V/ns	3.45:1
1168A/1169A	6 dB (2:1)	6.6 Vp-p	± 30 V*	6.3 mV RMS	se: 50 V/ns, diff: 80 V/ns	6.9:1
1168A/1169A	12 dB (4:1)	13.2 Vp-p	± 30 V*	13.2 mV RMS	se: 100 V/ns, diff: 160 V/ns	13.8:1
1168A/1169A	20 dB (10:1)	33.3 Vp-p	± 30 V*	33.4 mV RMS	se: 250 V/ns, diff: 400 V/ns	34.5:1

*The actual range of DC voltage for these attenuators is greater than ± 30 V, but the usable range of DC voltage at the probe input is limited to ± 30 Vdc.

Note: The values shown above do not apply to the N5380A dual-SMA probe head. Due to the maximum input voltage specification of 2.28 VRMS for the N5380A, it is not suitable for measuring signals large enough to require an added attenuator.

** These slew rate do not apply when the N5380A and E2695A SMA probe heads are used with the InfiniiMax amplifiers.

General Information

Using the N2880A InfiniiMax In-Line Attenuator Kit

Below are the frequency response plots for four setups: the probe without any attenuators, the probe with the 6 dB attenuators, the probe with the 12 dB attenuators, and the probe with the 20 dB attenuators.

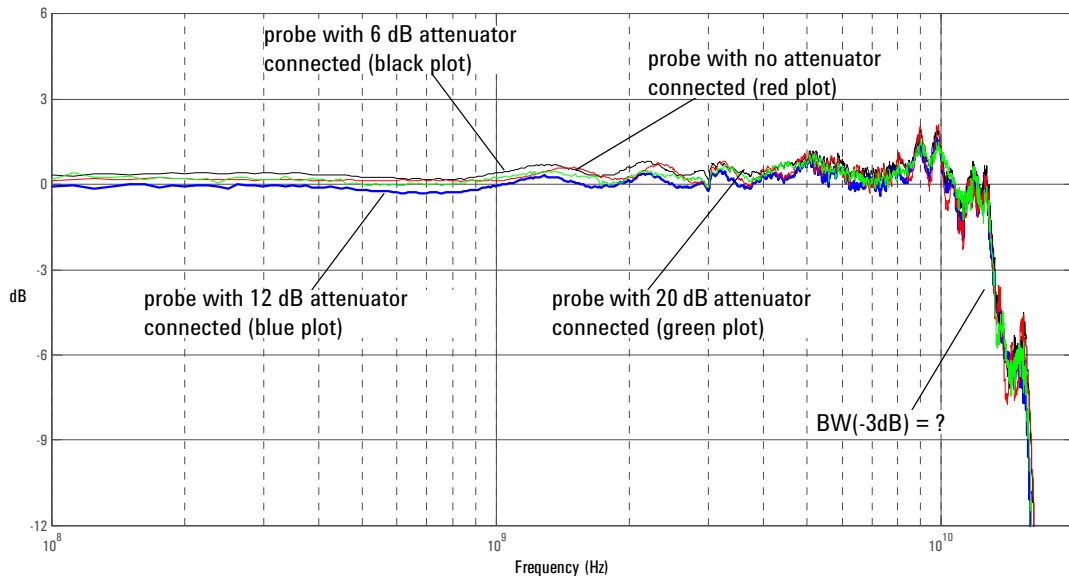

Graph of $\text{dB}(V_{\text{out}}/V_{\text{in}}) + 10.8 \text{ dB}$ of probe (red plot), $\text{dB}(V_{\text{out}}/V_{\text{in}}) + 6 \text{ dB}$ attenuator + 10.8 dB of probe (black plot), $\text{dB}(V_{\text{out}}/V_{\text{in}}) + 12 \text{ dB}$ attenuator + 10.8 dB of probe (blue plot), and $\text{dB}(V_{\text{out}}/V_{\text{in}}) + 20 \text{ dB}$ attenuator + 10.8 dB of probe (green plot)

The software in the Infiniium and InfiniiVision oscilloscopes will detect a probe when it is connected and by default will assume that no additional attenuators are installed. If you want to scale readings and settings on the oscilloscope so they are correct with the attenuators installed, refer to the procedures below for your specific oscilloscope series.

Calibrating Attenuators on an Infiniium Series Oscilloscope

You cannot calibrate your InfiniiMax probes with the attenuators attached. Please calibrate the InfiniiMax probes as you normally would (with no attenuators), configure the attenuators as discussed in the next section, and begin probing.

Configuring Attenuators on an Infiniium Series Oscilloscope

First, plug your InfiniiMax probe amplifier / probe head into one of the oscilloscope channels with the attenuators connected. Then enter the **Probe Setup** dialog box (can be reached via **Setup > Probes** on the oscilloscope menu). Press the **Configure Probing System** button. A pop-up window will appear where you can select **External Scaling**. Click the **Decibel** radio button under the *External Scaling* section and then set the **Gain** field to either -6 dB, -12 dB, or -20 dB depending on the attenuator you are using (be sure to include the negative sign). Finally, you will need to manually set the **Offset** field in this dialog box to zero out the signal.

N2881A InfiniiMax DC Blocking Caps

The architecture of the InfiniiMax probing system allows you to place the N2881A DC Blocking Caps in between the probe amplifier and the probe head (as shown in the picture below). These N2881A InfiniiMax DC Blocking Caps block out the DC component of the input signal (up to 30 V_{dc}).

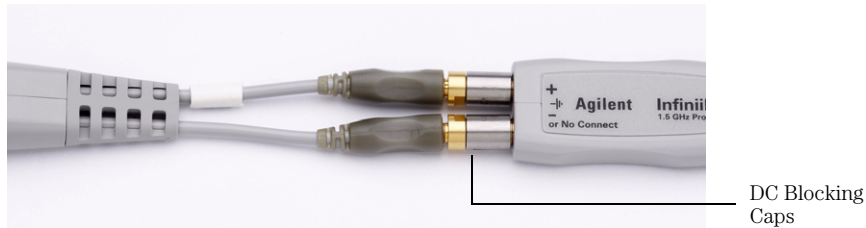

The N2881A InfiniiMax DC Blocking Caps can be used with the N2880A In-Line Attenuators. The order of the two products in the probing system (*i.e.* which one is closest to the probe amplifier) does not matter.

Below is the frequency response plot of the N2881A DC Blocking Caps (no probe included).

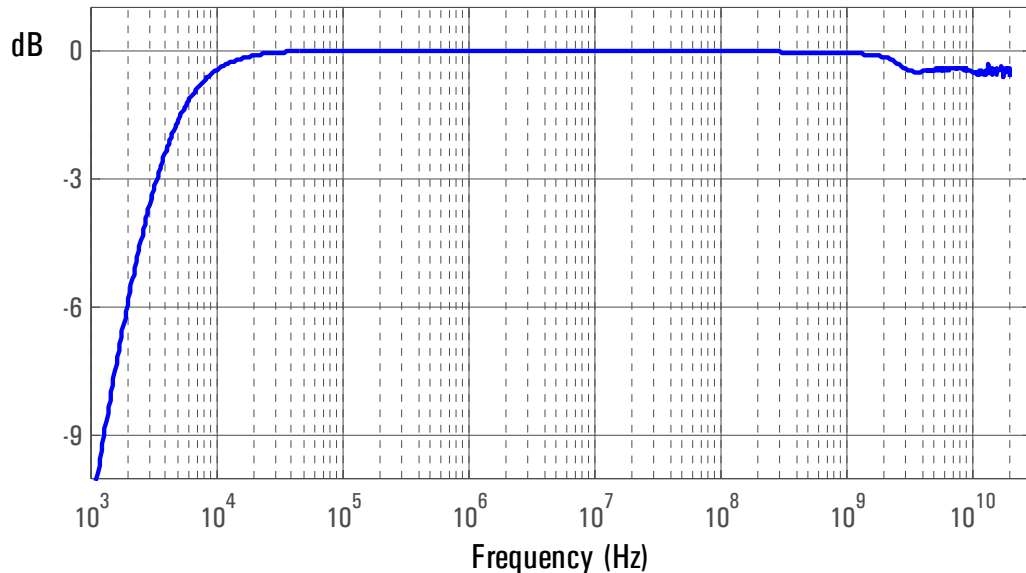

Graph of DC Blocking Cap insertion loss (S2,1) versus frequency (DC Blocking Cap only)

Using Probe Accessories

The probe configurations shown in this section are the ones recommended for the best performance for different probing situations.

Solder-in Differential Probe Head (Full Bandwidth)

This probe configuration provides the full bandwidth signals and the lowest capacitive loading for measuring both single-ended and differential signals. The probe head wires must be soldered to the circuit that you are measuring. Because of the small size of the wire leads, it is easy to solder them to very small geometry circuits.

Figure 1-46

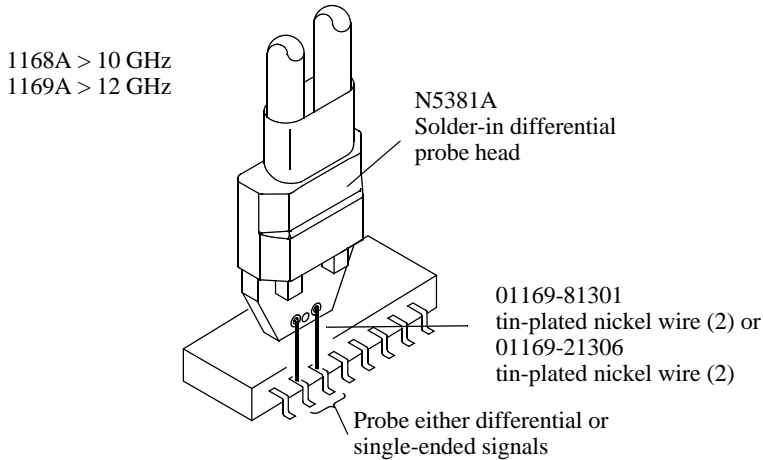

01169e006

General Information Using Probe Accessories

Differential Browser (Full Bandwidth)

The differential browser configuration is the best choice for general purpose troubleshooting of a circuit board for full bandwidth signals.

Figure 1-47

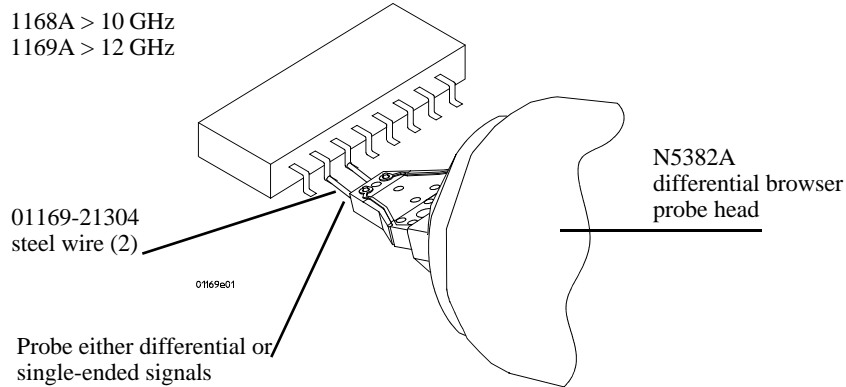

Adjusting the Spacing of the Differential Browser Wires

The best way to adjust the spacing of the differential browser wires is by using a pair of tweezers. By using a twisting motion rather than moving the wires around and putting stress at the solder joint, the wires will last much longer with multiple adjustments. See figure 1-48.

Figure 1-48

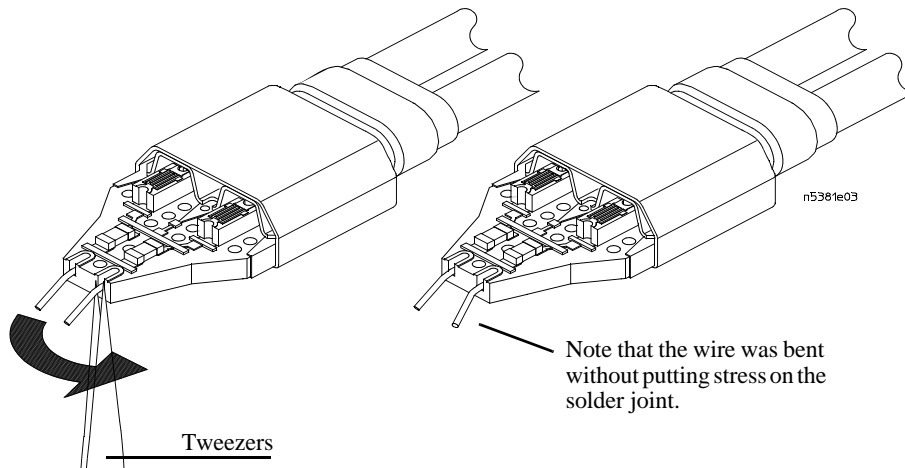

N5380A SMA Probe Head (Full Bandwidth)

This probe head provides the highest bandwidth for connecting to SMA connectors. The input resistance is $50\ \Omega$ on both inputs. The shorting cap connects one side of both resistances to ground. For applications that require the resistances to be referenced to a voltage other than ground, the shorting cap can be removed and a dc voltage can be applied. When using this probe head, always use the N5380-64701 SMA Head Support (see page 76) to prevent damage to the probe amplifier.

Figure 1-49

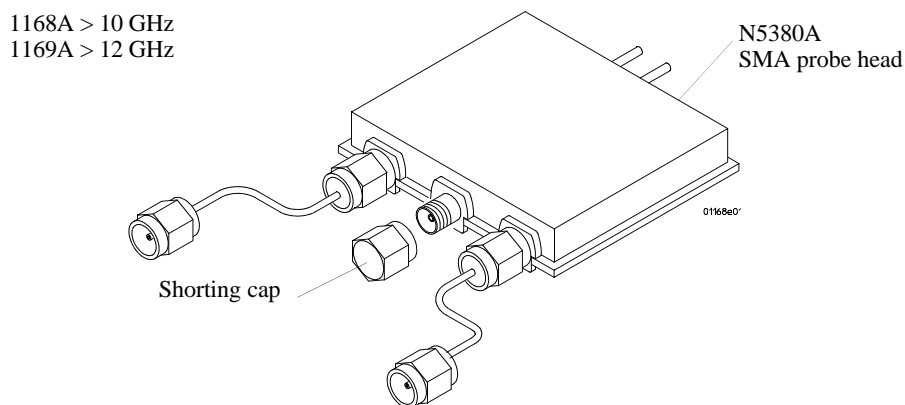

ZIF Probe Head (High Bandwidth)

This probe configuration provides the high bandwidth signals and the lowest capacitive loading for measuring both single-ended and differential signals. The ZIF Tip must be soldered to the circuit that you are measuring.

Figure 1-50

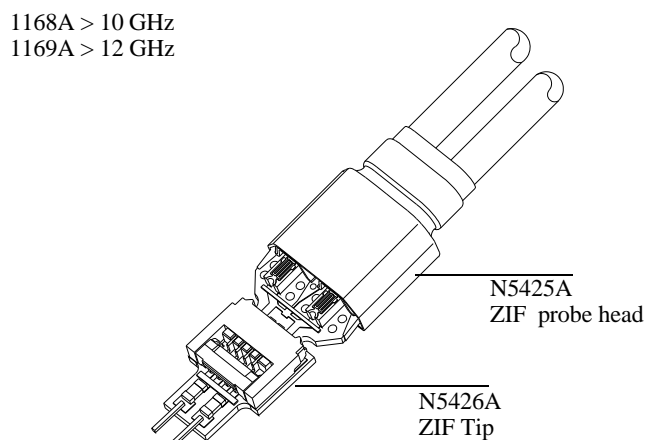

General Information Using Probe Accessories

Long Wired ZIF Probe Head

The Long Wired ZIF Tip must be soldered to the circuit you are measuring. Use the shortest resistor length (7 mm or 11 mm) necessary for your application.

Figure 1-51

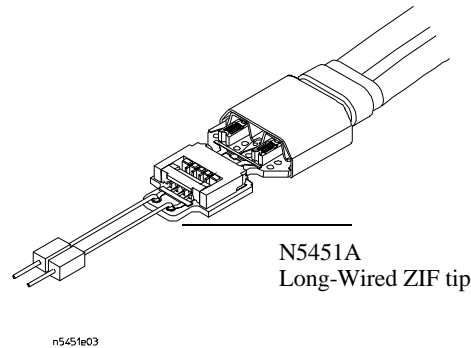

Socketed Differential Probe Head (High Bandwidth)

This probe configuration provides the high bandwidth signals and minimal capacitive loading for measuring both single-ended and differential signals. The $82\ \Omega$ axial lead resistors are soldered to the circuit that you are measuring. The socketed differential probe head is plugged on to the resistors. This makes it easier to move the probe from one location to another. Because of the larger size of the resistor leads, the target for soldering must be larger than the solder-in probe heads.

The spacing for the socketed tip differential probe head is 0.100 inch (2.54 mm). If the resistors are to be soldered onto a PC board, the targets on the board should be two vias that can accept the 0.020 inch (0.508 mm) diameter resistor leads. A via of 0.025 inch (0.635 mm) diameter is recommended. If soldering a resistor lead to a surface pad on your PC board, the resistor leads can be bent in an “L” shape and soldered down. A pad size of at least 0.030 x 0.030 inch (0.762 mm x 0.762 mm) is recommended.

Figure 1-52

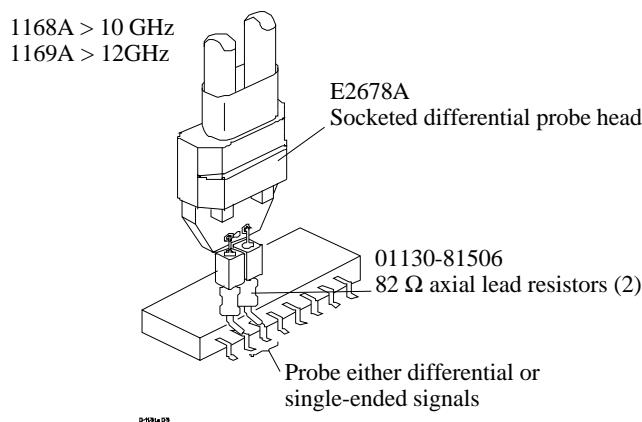

Differential Browser

The differential browser configuration is the best choice for general purpose troubleshooting of a circuit board. The tab on the side of the probe allows the probe tips to be adjusted for different circuit geometries.

Figure 1-53

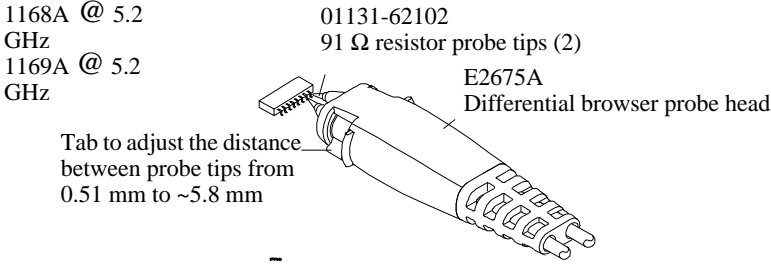

Solder-in Single-ended Probe Head (High Bandwidth)

This probe configuration provides good bandwidth measurements of single-ended signals with a probe head that is physically very small. The probe head resistors must be soldered to the circuit that you are measuring. Because of the small size of the resistor leads, it is easy to solder them to very small geometry circuits.

Figure 1-54

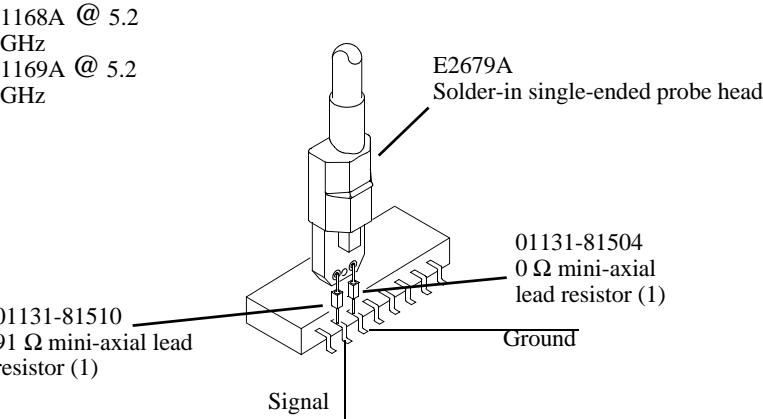

General Information Using Probe Accessories

Single-ended Browser

The single-ended browser is a good choice for general purpose probing of single-ended signals when physical size is critical. Excessive peaking (+6 dB) can occur at about 9 GHz. Therefore, limit the bandwidth of the input signal.

For wider span, non-performance critical browsing (rise times greater than ~0.5 ns), the 5063-2120 socketed ground lead can be used in place of the 01130-60005 ground collar.

Figure 1-55

1168A @ 6 GHz
1169A @ 6 GHz

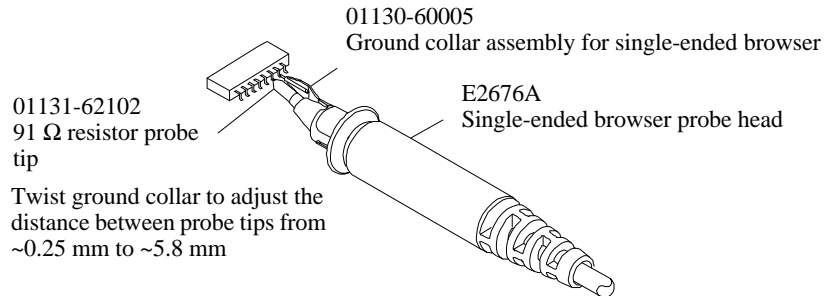

Socketed Differential Probe Head with Damped Wire Accessory

This probe configuration provides maximum connection reach and flexibility with good signal fidelity but lower bandwidth for measuring differential or single-ended signals. The damped wires must be soldered to the circuit that you are measuring. This configuration can probe circuit points that are farther apart than other configurations.

To adapt the 01130-21302 damped wire accessory from solder-in to plug-on, solder the tip into the 01131-85201 square pin socket and then slip the 01131-41101 heat-shrink sleeve over the solder joint and heat the heat-shrink tubing with a heat gun. This allows the damped wire accessories to be used to plug onto 25 mil square pins.

Figure 1-56

1168A @ 1.2 GHz
1169A @ 1.2 GHz

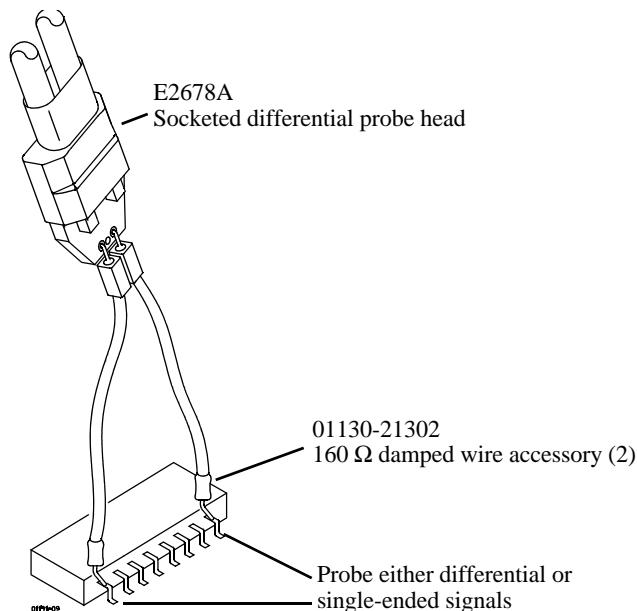

Socketed Differential Probe Head with 01130-63201 Header Adapter

This probe configuration can be used to connect to 25 mil square pin headers with 100 mil spacing such as those used in USB testing. If the header adapter is used with the 1168A (10 GHz) or the 1169A (12 GHz), the rise time of the input signal should be slower than ~150 ps (10% to 90%) to limit the effects of resonances in the adapter.

All of the specifications and characteristics of the header adapter are the same as those for the Socketed Differential Probe Head except for the input capacitance shown in the following table.

Table 1-9

Characteristic Capacitance		
C_m	0.43 pF	Model for input C is C_m between the tips and C_g to ground each tip
C_g	0.54 pF	
C_{diff}	0.70 pF	Diff mode capacitance is $C_m + C_g/2$
C_{se}	0.97 pF	Se mode capacitance is $C_m + C_g$

Figure 1-57

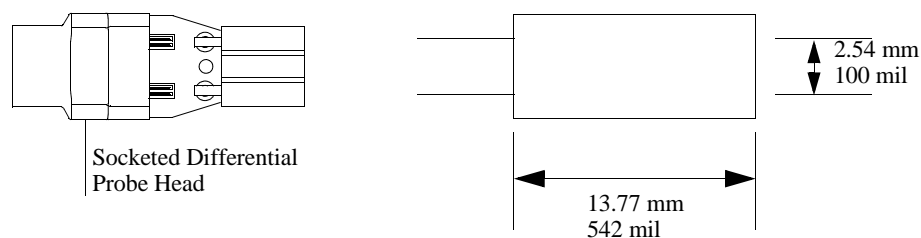

01130-63201 Header Adapter Dimensions

Differential and Single-ended Probe Configurations

Introduction

The 1168A and 1169A InfiniiMax II Active Probing system allows probing of differential and single-ended signals to a bandwidth of over 10 GHz for the 1168A and 12 GHz for the 1169A. The unique architecture of the InfiniiMax probe system provides a large common mode range for measuring differential signals and a large offset range for measuring single-ended signals. Additionally, the lower attenuation and noise greatly enhance the measurement of low-level signals that are so prevalent today, without overly sacrificing the input dynamic range. This family of probes continues the resistor-at-the-tip technology that Agilent pioneered in the 115x and 113x probe families. In this new probe family, the resistors have been moved onto the very edge of the probe tip board because at these extreme frequencies the off-board mini-axial lead resistors cause more response variation than is desirable. The wires or probe tips in front of the resistors are long enough to allow easy connection but are short enough that any resonances caused by them are out of band and don't impact the input impedance. This system uses interchangeable probe heads to optimize the performance and usability of hand (or probe holder) browsing, solder-in, and SMA connections. The new probe heads available for this system are:

- **Differential Solder-in Probe Head** — allows a soldered connection into a system for a reliable hands-free connection. This probe head provides full bandwidth performance for measuring differential and single-ended signals and utilizes strong 7 mil (or optional 5 mil) diameter nickel wires, which allow connection to very small, fine pitch targets.
- **Differential Hand-held Browser** — (or for probe holders) allows temporary connection to points in a system. This probe head has the same tip pc board and the same length tip wires so it provides the same full bandwidth performance and fidelity as the solder-in probe head for measuring differential and single-ended signals. The tip wires for this probe head are tin plated spring steel that can be formed to different spacing and provide compliance for a reliable connection.
- **Differential Socket-tip Probe Head** — provides sockets that accept 20 mil diameter pins with 100 mil spacing. The intended application for this probe head is to insert two of the supplied 20 mil diameter lead resistors into the sockets and then solder the resistors into the target system. This allows a removable, hands-free connection that provides full bandwidth, but with an increase in capacitive loading over the solder-in and browser probe heads. Additionally, 3.6 cm resistor tip wire accessories are provided for high fidelity lower bandwidth probing of signals with very wide spacing. It is recommended that a 25 mil diameter plated through hole be placed on a board for mounting the 20 mil diameter lead of the resistors.
- **SMA Probe Head** — allows connection to differential and single-ended signals that have 50 Ω connectors. This probe head provides full bandwidth performance with high quality 50 Ω terminations and an external port for driving the common mode termination voltage. This is a relatively inexpensive probe head for the 1168A and 1169A probe amps, which allows the probe amp to be used in multiple applications. When using this probe head, always use the N5380-64701 SMA Head Support to prevent damage to the probe amplifier.
- **ZIF Probe Head** — allows connection to differential and single-ended signals that have 50 Ω connectors. This probe head provides full bandwidth performance with high quality 50 Ω terminations and an external port for driving the common mode termination voltage. This is a relatively inexpensive probe head for the 1168A and 1169A probe amps, which allows the probe amp to be used in multiple applications.

Also, probe heads from the 113x probe family are supported within the limitations which are noted. Please refer to the 1134A User's Guide for information on these probe heads. Performance graphs and data are provided for all probe heads.

Convenience Accessories

Using the Velcro strips and dots

The Velcro strips and dots can be used to secure the probe amp to a circuit board removing the weight of the probe from the circuit connection. This is done by using the following steps.

- 1) Wrap the Velcro strip around the probe amp body.
- 2) Attach a Velcro dot to the circuit board.
- 3) Attach the Velcro strip to the Velcro dot.

Figure 2-1

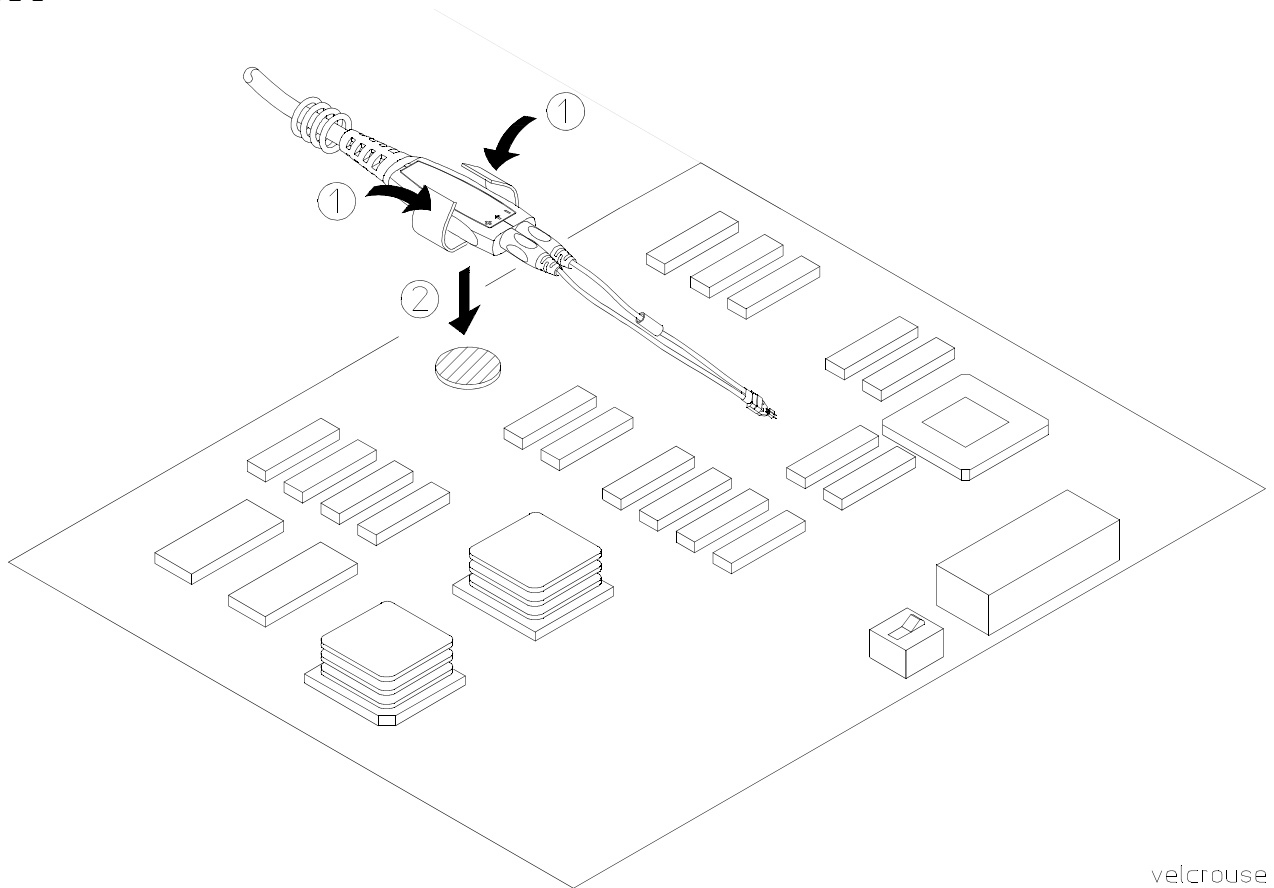

Using the Velcro dots and strips.

Using the ergonomic handle

Because of their small size, it can be difficult to hold the single-ended or the differential browsers for extended periods of time. The ergonomic handle can be used to more comfortably hold the browser. The following pictures show how to mount the browser in the ergonomic handle.

Differential and Single-ended Probe Configurations Convenience Accessories

Figure 2-2

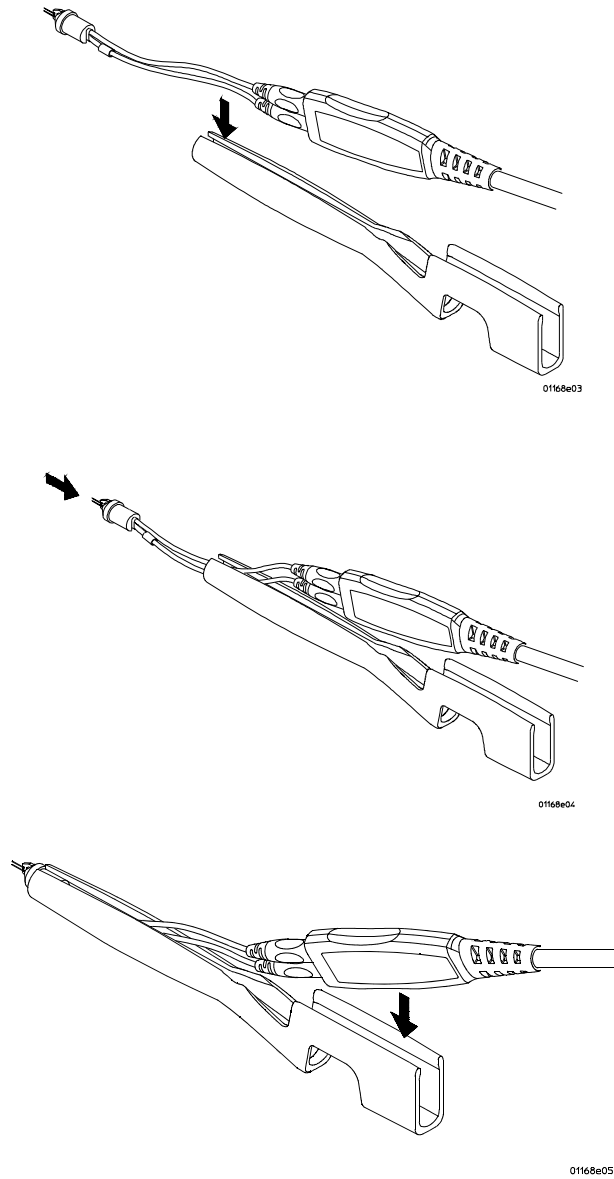

The following pictures show how to remove the browser from the ergonomic handle.

Figure 2-3

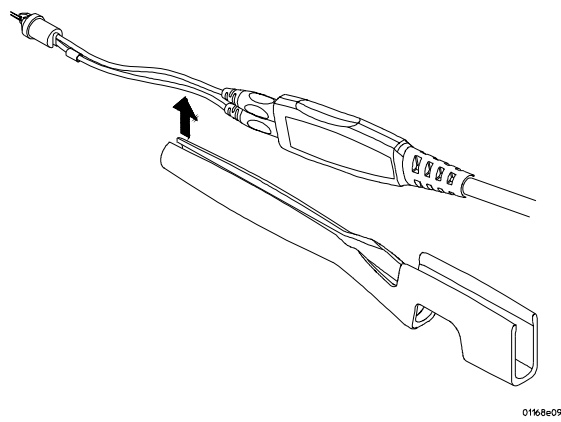
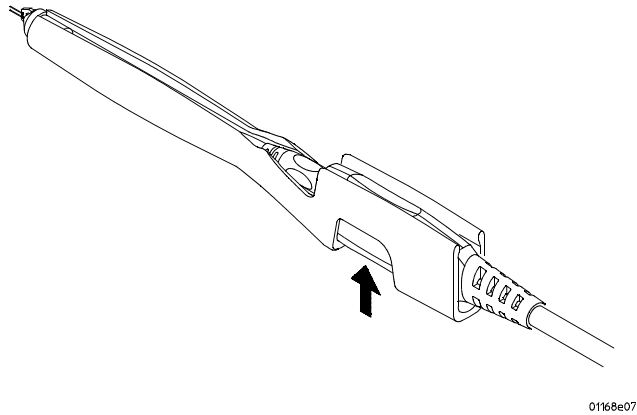

**Differential and Single-ended Probe Configurations
Slew Rate Requirements for Different Technologies**

Slew Rate Requirements for Different Technologies

The following table shows the slew rates for several different technologies. The maximum allowed input slew rate is 18 V/ns for single-ended signals and 30 V/ns for differential signals. Table 2-1 shows that the maximum required slew rate for the different technologies is much less than that of the probe.

Table 2-1

Slew Rate Requirements

Name of Technology	Differential Signal	Max Single-Ended Slew Rate ¹ (V/ns)	Max Differential Slew Rate ² (V/ns)	Driver Min Edge Rate (20%-80% ps)	Max Transmitter Level (Diff V)
PCI Express (3GIO)	YES	9.6	19.2	50	1.6
RapidIO Serial 3.125Gb	YES	8.0	16.0	60	1.6
10GbE XAUI (4x3.125Gb)	YES	8.0	16.0	60	1.6
1394b	YES	8.0	16.0	60	1.6
Fibre Channel 2125	YES	8.0	16.0	75	1
Gigabit Ethernet 1000Base-CX	YES	7.8	15.5	85	2.2
RapidIO 8/16 2Gb	YES	7.2	14.4	50	1.2
Infiniband 2.5Gb	YES	4.8	9.6	100	1.6
HyperTransport 1.6Gb	YES	4.0	8.0	113	1.5
SATA (1.5Gb)	YES	1.3	2.7	134	0.6
USB 2.0	YES	0.9	1.8	375	1.1
DDR 200/266/333	NO	7.2	n/a	300	3.6
PCI	NO	4.3	n/a	500	3.6
AGP-8X	NO	3.1	n/a	137	0.7

¹ The probe specification is 18 V/ns

² The probe specification is 30 V/ns

Figure 2-4

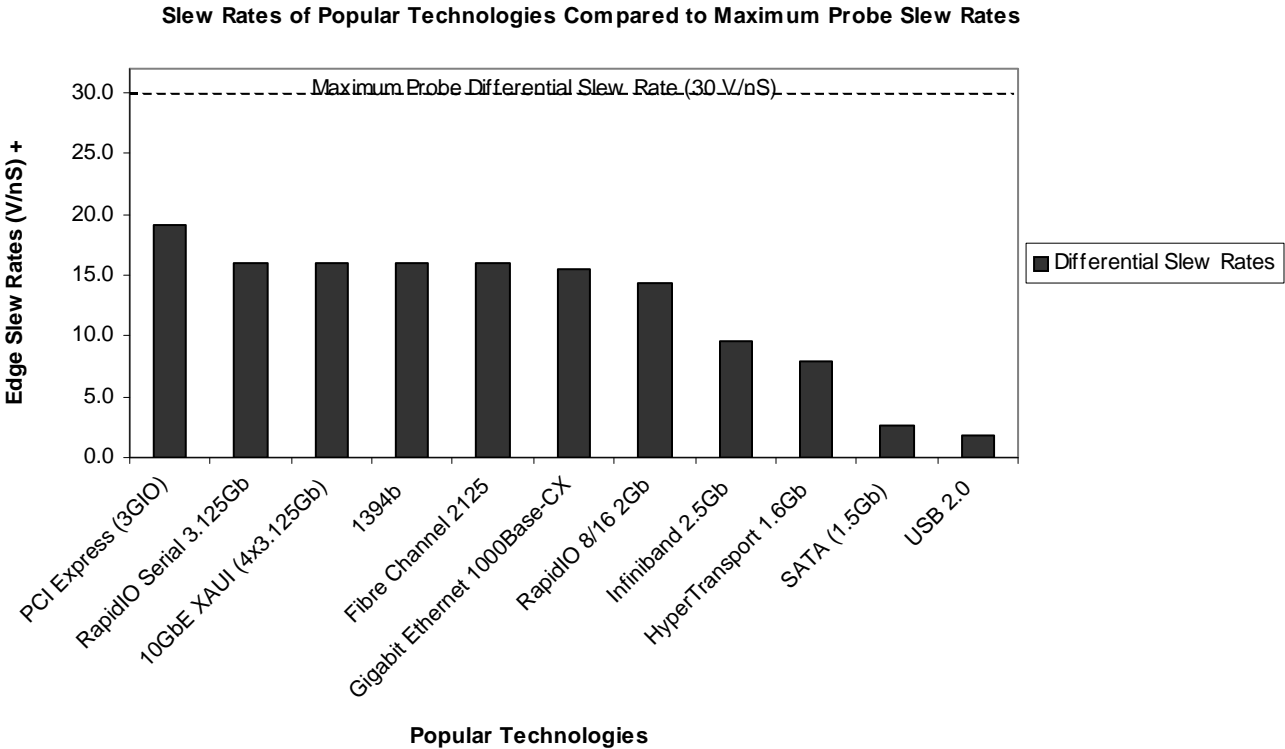

$$\frac{\text{Maximum Edge Amplitude} \times 0.6}{\text{Minimum 20\% to 80\% Rise Time}}$$

Differential and Single-ended Probe Configurations Slew Rate Requirements for Different Technologies

Figure 2-5

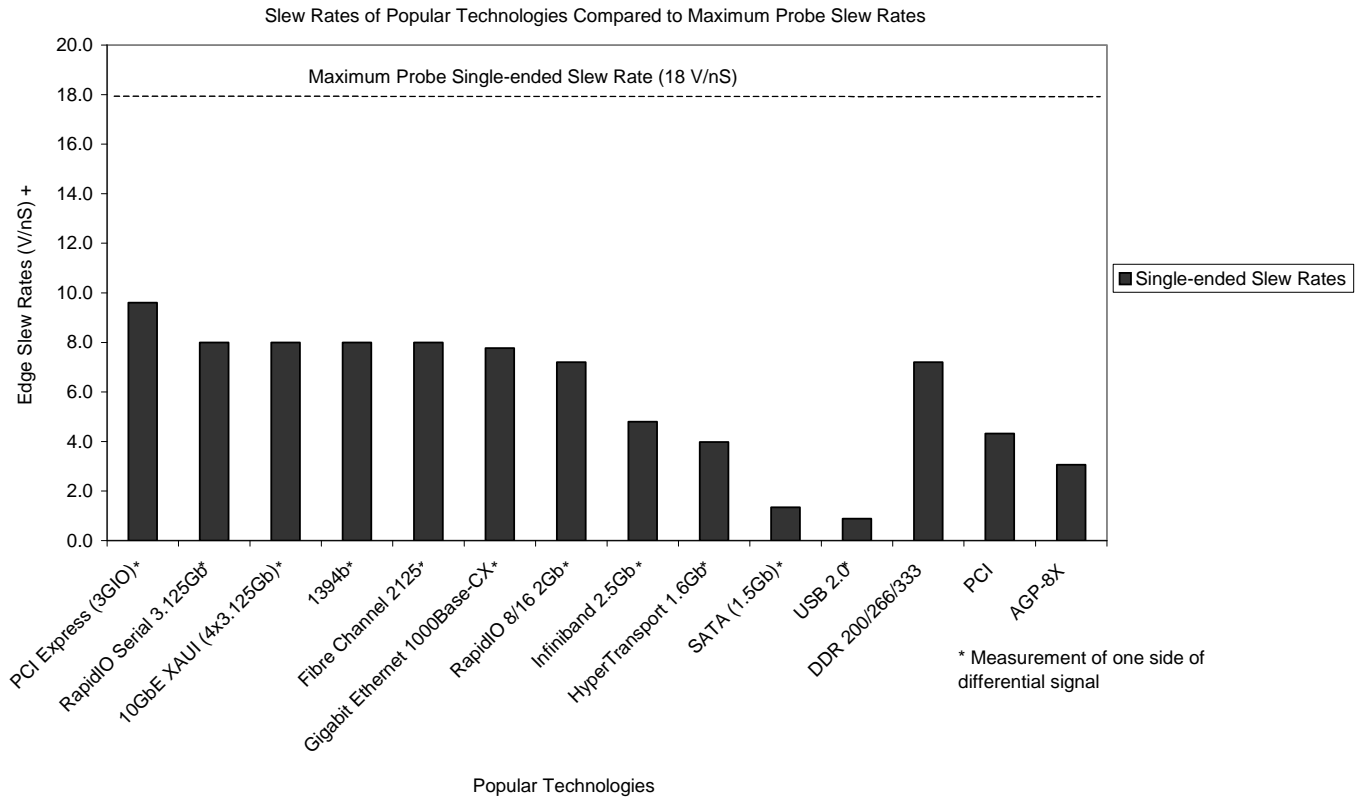

$$+ \frac{\text{Maximum Edge Amplitude} \times 0.6}{\text{Minimum 20\% to 80\% Rise Time}}$$

Recommended Configurations Overview

The recommended configurations are designed to give the best probe performance for different probing situations. The probe configurations are shown in the order of the best performance to the least performance.

Recommended configurations at a glance

Table 2-2

Probe Head Configurations	Bandwidth (GHz)	Cdiff ¹ (pF)	Cse ² (pF)	Starting Page of Performance Graphs	Usage
1st Choice N5381A Soldier-in differential (full bandwidth)	> 10 (1168A) > 12 (1169A)	0.21	0.35	2-24	<ul style="list-style-type: none"> Differential and Single-ended signals Solder-in hands free connection Hard to reach targets Very small fine pitch targets Characterization
2nd Choice N5382A Differential browser (full bandwidth)	> 10 (1168A) > 12 (1169A)	0.21	0.35	2-24	<ul style="list-style-type: none"> Differential and Single-ended signals Hand-held browsing Probe holders General purpose troubleshooting Ergonomic handle available
3rd Choice N5380A SMA ³ (full bandwidth)	> 10 (1168A) > 12 (1169A)	N/A	N/A	2-27	<ul style="list-style-type: none"> Full bandwidth Preserve oscilloscope channels as opposed to using the A minus B mode. Removes inherent cable loss through compensation. Common mode termination voltage can be applied Offset matched sma cables adapt to variable spacing
4th Choice N5425A ZIF (full bandwidth)	> 10 (1168A) > 12 (1169A)	0.33	0.53	2-30	<ul style="list-style-type: none"> Differential and Single-ended signals Solder-in with ZIF Tip connection Very small fine pitch target Slightly higher loading than solder-in probe head
5th Choice N5425A ZIF with N5451A Long Wired ZIF tip (7 mm resistor length)	~ 9.9 (0° span) ⁴ ~ 4.4 (60° span) ⁵	- -	0.6 0.58	2-34 2-36	<ul style="list-style-type: none"> Differential and Single-ended signals Solder-in with LW ZIF Tip connection Variable pitch targets, including larger pitches Higher loading than solder-in probe head
6th Choice N5425A ZIF with N5451A Long Wired ZIF tip (11 mm resistor length)	~ 5 (0° span) ⁴ ~ 3.3 (60° span) ⁵	- -	0.68 0.68	2-39 2-42	<ul style="list-style-type: none"> Differential and Single-ended signals Solder-in with LW ZIF Tip connection Variable pitch targets, including larger pitches Higher loading than solder-in probe head

¹ Capacitance seen by differential signals

² Capacitance seen by single-ended signals

³ Always use the N5380-64701 SMA Head Support with this probe head to prevent damage to the probe amplifier

⁴ 0° span between the two LW ZIF resistor leads

⁵ 60° span between the two LW ZIF resistor leads

Differential and Single-ended Probe Configurations Recommended Configurations Overview

Other configurations at a glance

Table 2-3

Probe Head Configurations	Bandwidth (GHz)	Cdiff ¹ (pF)	Cse ² (pF)	Starting Page of Performance Graphs	Usage
7th Choice E2677A Solder-in differential (high bandwidth resistors)	> 10 (1168A) > 12 (1169A)	0.27	0.44	2-46	<ul style="list-style-type: none"> Differential and Single-ended signals Solder-in hands free connection Hard to reach targets Very small fine pitch targets Characterization
8th Choice E2678A Socketed differential (high bandwidth resistors)	> 10 (1168A) > 12 (1169A)	0.34	0.56	2-48	<ul style="list-style-type: none"> Differential and Single-ended signals Removable connection using solder-in resistor pins Hard to reach targets
9th Choice E2675A Differential browser	~ 5.2	0.32	0.57	2-50	<ul style="list-style-type: none"> Differential and Single-ended signals Hand-held browsing Probe holders General purpose troubleshooting Ergonomic handle available
10th Choice E2679A Solder-in single-ended (high bandwidth resistors)	~ 5.2	N/A	0.50	2-52	<ul style="list-style-type: none"> Single-ended signals only Solder-in hands free connection when physical size is critical Hard to reach targets Very small fine pitch targets
11th Choice E2676A Single-ended browser	~ 6	N/A	0.65	2-54	<ul style="list-style-type: none"> Single-ended signals only Hand or probe holder where physical size is critical General purpose troubleshooting Ergonomic handle available
12th Choice E2678A Socketed differential with damped wire accessories	~ 1.2	0.63	0.95	2-56	<ul style="list-style-type: none"> Differential and Single-ended signals For very wide spaced targets Connection to 25 mil square pins when used with supplied sockets
13th Choice E2695A SMA ³	~ 8	N/A	N/A	2-58	<ul style="list-style-type: none"> Not full bandwidth but good signal fidelity Preserve oscilloscope channels as opposed to using the A minus B mode. Removes inherent cable loss through compensation. Common mode termination voltage can be applied Offset sma cables adapt to variable spacing

¹ Capacitance seen by differential signals

² Capacitance seen by single-ended signals

³ Always use the N5380-64701 SMA Head Support with this probe head to prevent damage to the probe amplifier

1st Choice: Solder-in Differential Probe Head (full bandwidth)

This configuration has a bandwidth of greater than 10 GHz for the 1168A and 12 GHz for the 1169A (see the graphs starting on page 2-46). The configuration consists of the following parts:

- N5381A — Solder-in Differential Probe Head
- 01169-81301 — tin-plated nickel wires (2 each)

The 01169-81301 wire has been trimmed and formed using trim gauge 01169-23801.

Figure 2-6

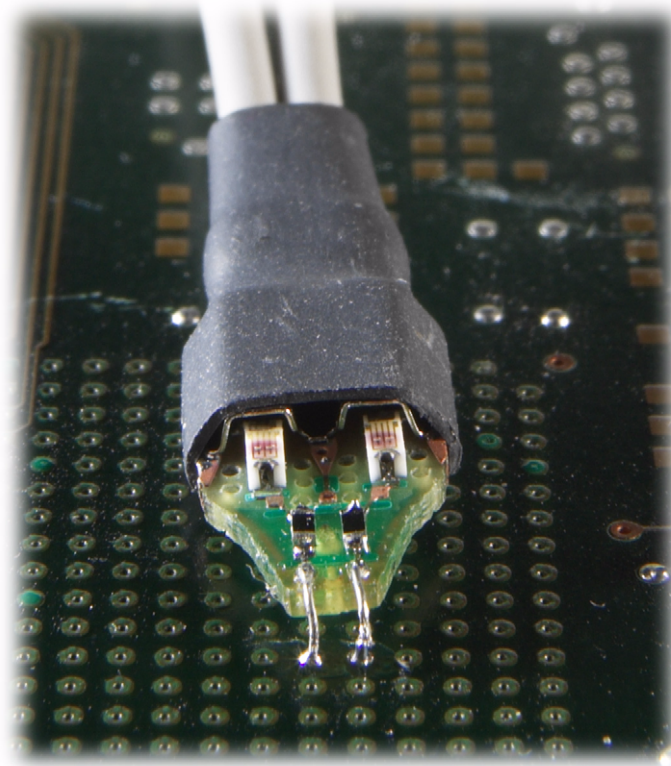

Differential and Single-ended Probe Configurations Recommended Configurations Overview

2nd Choice: Differential Browser Probe Head (full bandwidth)

This configuration has a bandwidth of greater than 10 GHz for the 1168A and 12 GHz for the 1169A (see the graphs starting on page 2-46). The configuration consists of the following parts:

- N5382A — Differential Browser Probe Head
- 01130-43202 — Ergonomic handle
- 01169-21304 — tin-plated steel wires (2 each)

The 01169-21304 wire has been trimmed and formed using trim gauge 01169-23801.

Figure 2-7

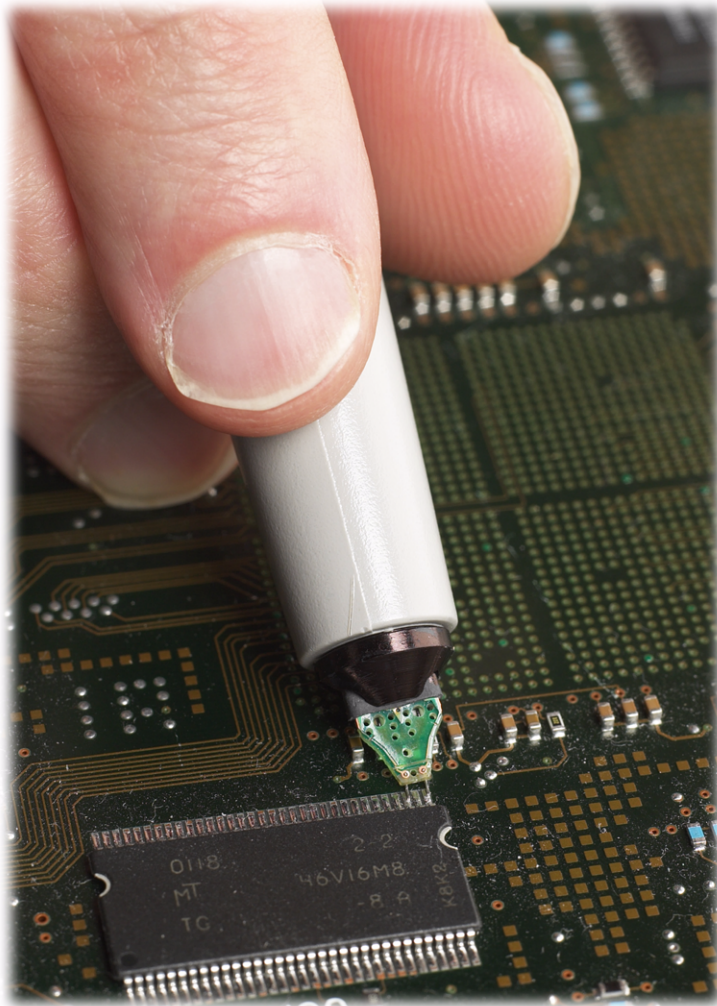

3rd Choice: SMA Probe Head (full bandwidth)

This configuration has a bandwidth of greater than 10 GHz for the 1168A and 12 GHz for the 1169A (see the graphs starting on page 2-46). The two outside SMA connectors are for input signal connection and the center SMA connector can be used to provide a dc bias for the termination. The configuration consists of the following parts:

- N5380A — SMA Probe Head

When using this probe head, always use the N5380-64701 SMA Head Support to prevent damage to the probe amplifier.

Figure 2-8

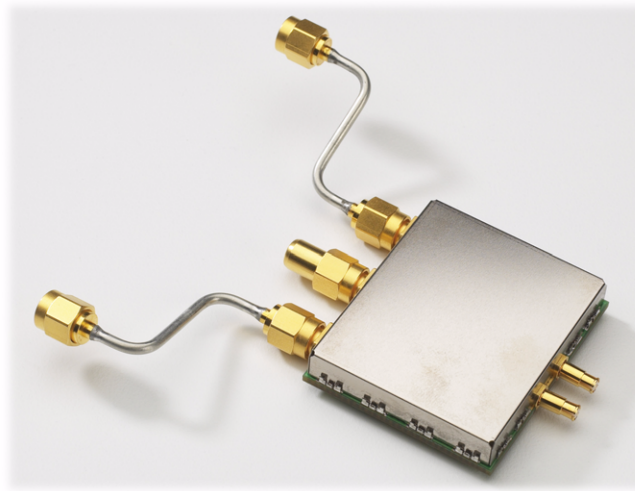

SMA Probe Head Schematic

N5380A SMA Probe Head

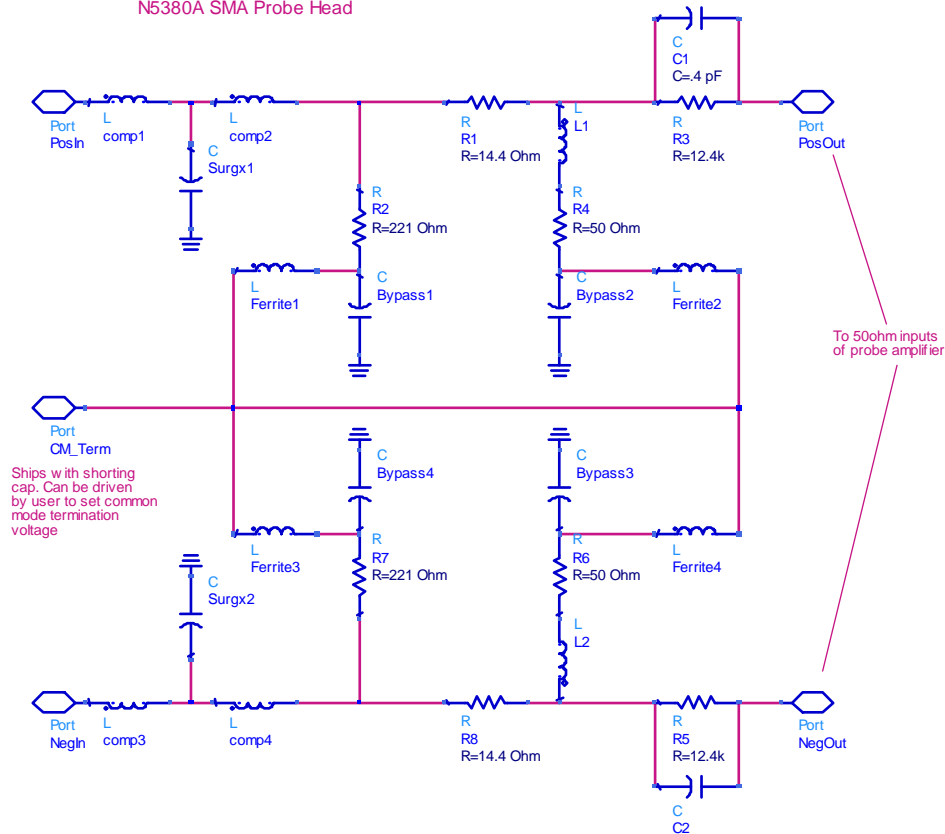

Differential and Single-ended Probe Configurations Recommended Configurations Overview

4th Choice: ZIF Probe Head

This configuration has a bandwidth of greater than 10 GHz for the 1168A and 12 GHz for the 1169A (see the graphs starting on page 2-30). The configuration consists of the following parts:

- N5425A — ZIF Probe Head
- N5426A — ZIF Probe Head Accessory

Figure 2-9

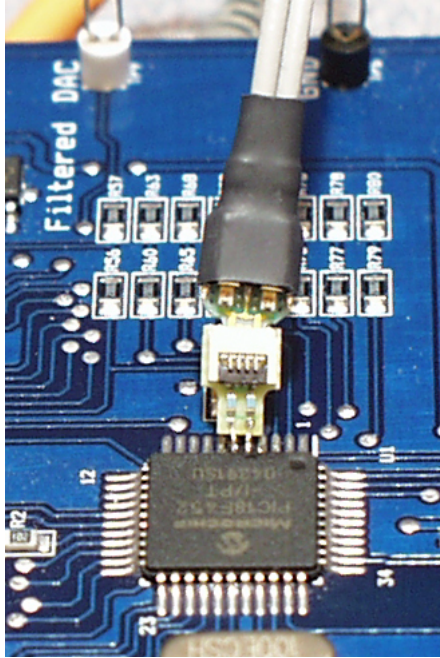

ZIF Probe Head

5th Choice: ZIF Probe Head with Long Wired ZIF Tip - 7mm Resistor Length

This configuration has a bandwidth of greater than 9 GHz (see the graphs starting on page 2-34). The configuration consists of the following parts:

- N5425A — ZIF Probe Head
- N5451A — Long Wired ZIF Probe Head Accessory

The N5451A resistors have been trimmed and formed using template N5451A-94301.

Figure 2-10

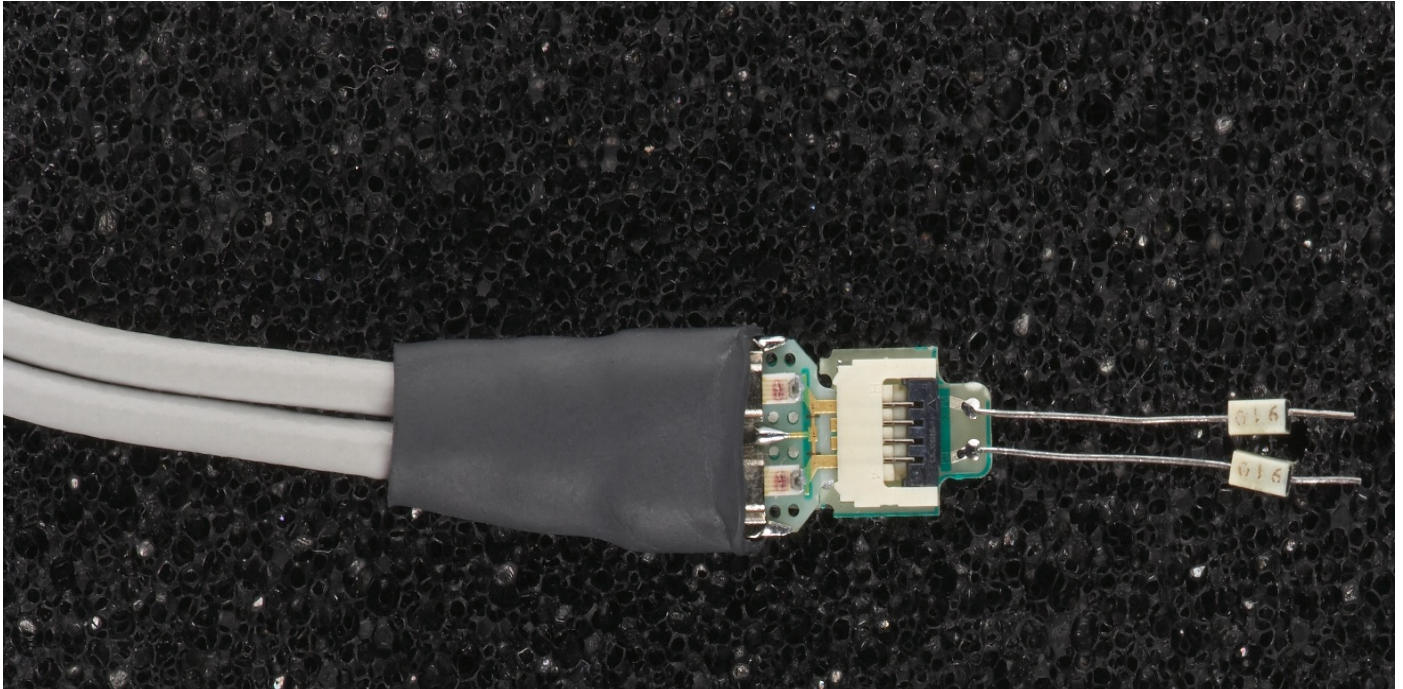

Resistor wire lengths shown are not 7 mm and the figure has been enlarged to show detail.

Differential and Single-ended Probe Configurations Recommended Configurations Overview

6th Choice: ZIF Probe Head with Long Wired ZIF Tip - 11 mm Resistor Length

This configuration has a bandwidth of 5 GHz (see the graphs starting on page 2-39). The configuration consists of the following parts:

- N5425A — ZIF Probe Head
- N5451A — Long Wired ZIF Probe Tip

The N5451A resistors have been trimmed and formed using template N5451A-94301.

Figure 2-11

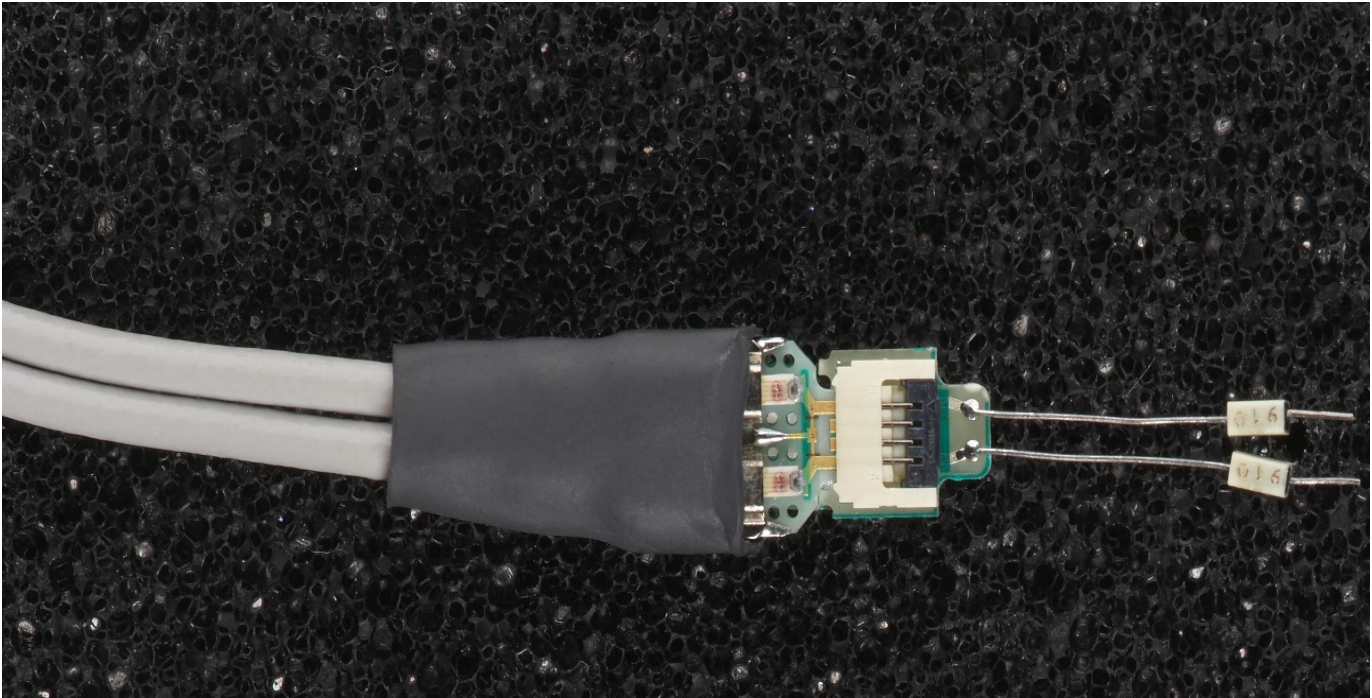

Resistor wire lengths shown are not 11 mm and the figure has been enlarged to show detail.

Other Configurations Overview

Other configurations of probe heads are available in the E2669A connectivity kit. Not all of these configurations will give the best probe performance of the 1168A and 1169A. The probe configurations are shown in the order of the best performance to the least performance.

7th Choice: Solder-in Differential Probe Head (high bandwidth resistors)

This configuration has a bandwidth of greater than 10 GHz for the 1168A and 12 GHz for the 1169A (see the graphs starting on page 2-46). The configuration consists of the following parts:

- E2677A — Solder-in Differential Probe Head
- 01131-81510 — 91 Ω mini-axial lead resistors (2 each)

The 01131-81510 resistor has been trimmed and formed using template 01131-94311.

Figure 2-12

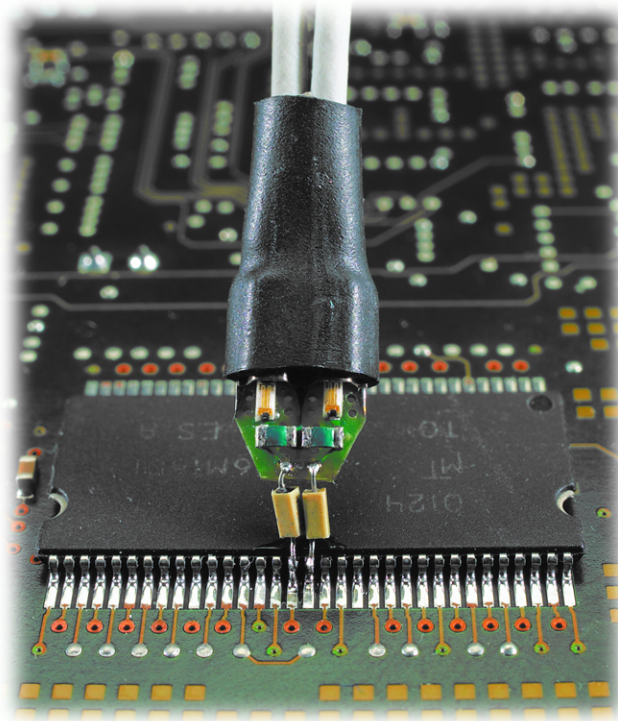

Differential and Single-ended Probe Configurations Other Configurations Overview

8th Choice: Socketed Differential Probe Head (high bandwidth resistors)

This configuration has a bandwidth of greater than 10 GHz for the 1168a and 12 GHz for the 1169A (see the graphs starting on page 2-48). This configuration consists of the following parts:

- E2678A — Socketed Differential Probe Head
- 01130-81506 — 82 Ω axial lead resistors (2 each)

The 01130-81506 resistor has been trimmed and formed using template 01131-94308.

Figure 2-13

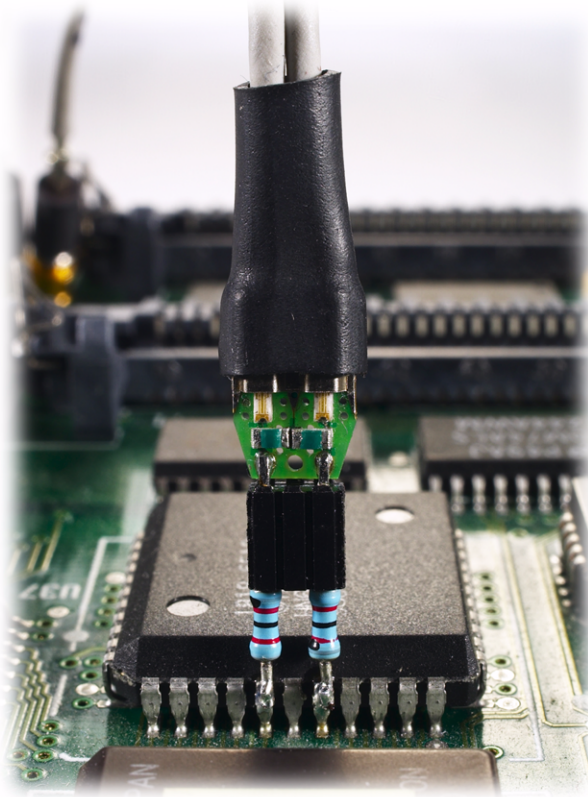

9th Choice: Differential Browser Probe Head

This configuration has a bandwidth approximately equal to 5.2 GHz for the 1168A and 6 GHz for the 1169A (see the graphs starting on page 2-50). This configuration consists of the following parts:

- E2675A — Differential Browser Probe Head
- 01131-62102 — 91 Ω resistor probe tips (2 each)
- 01131-43201 — Ergonomic handle (optional)

Figure 2-14

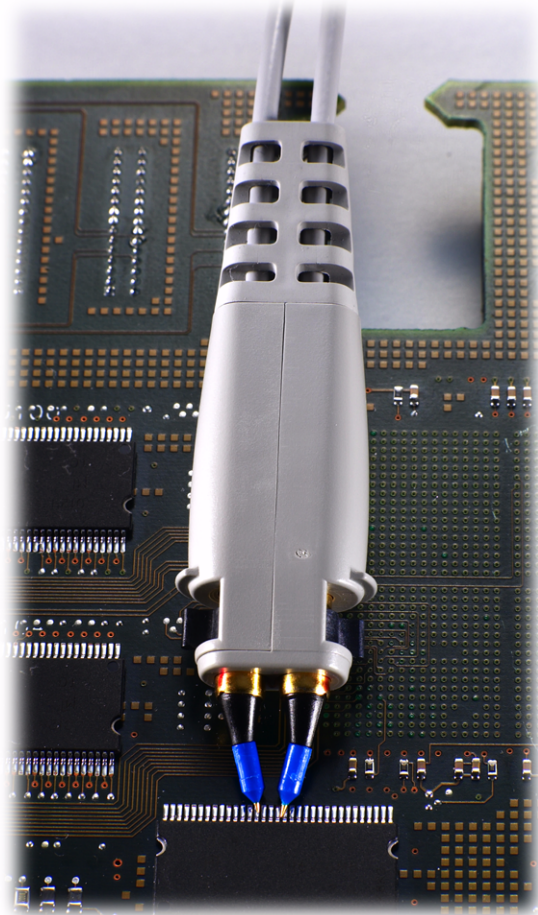

Differential and Single-ended Probe Configurations Other Configurations Overview

10th Choice: Solder-in Single-ended Probe Head (high bandwidth resistors)

This configuration has a bandwidth approximately equal to 5.2 GHz for the 1168A and 6 GHz for the 1169A (see the graphs starting on page 2-52). This configuration consists of the following parts:

- E2679A — Solder-in Single-ended Probe Head
- 01131-81510 — 91 Ω mini-axial lead resistor
- 01131-81504 — 0 Ω mini-axial lead resistor

The 01131-81510 and 01131-81504 resistors have been trimmed and formed using template 01131-94311.

Figure 2-15

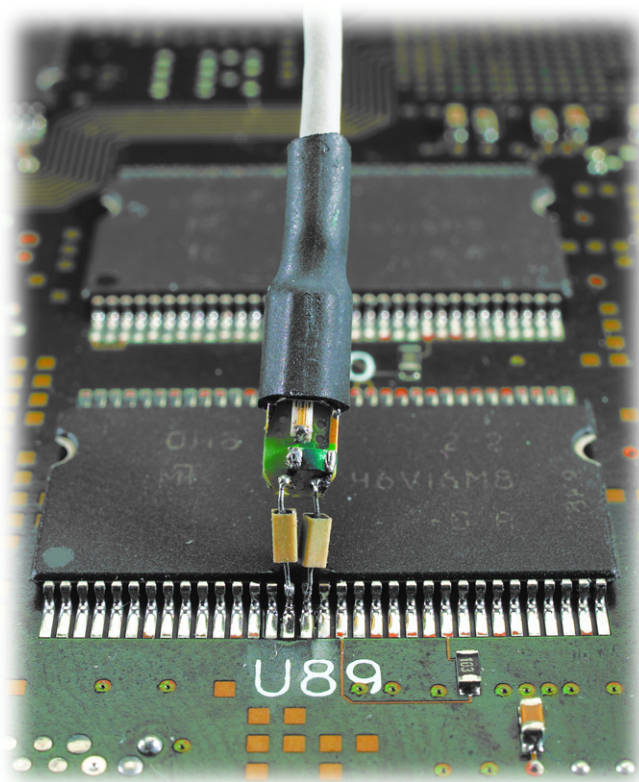

11th Choice: Single-ended Browser Probe Head

This configuration has a bandwidth approximately equal to 6 GHz (see the graphs starting on page 2-54). This configuration consists of the following parts:

- E2676A — Single-ended Browser Probe Head
- 01131-43202 — Ergonomic handle (optional)
- 01131-62102 — 91 Ω resistor probe tip
- 01130-60005 — Ground collar assembly

Figure 2-16

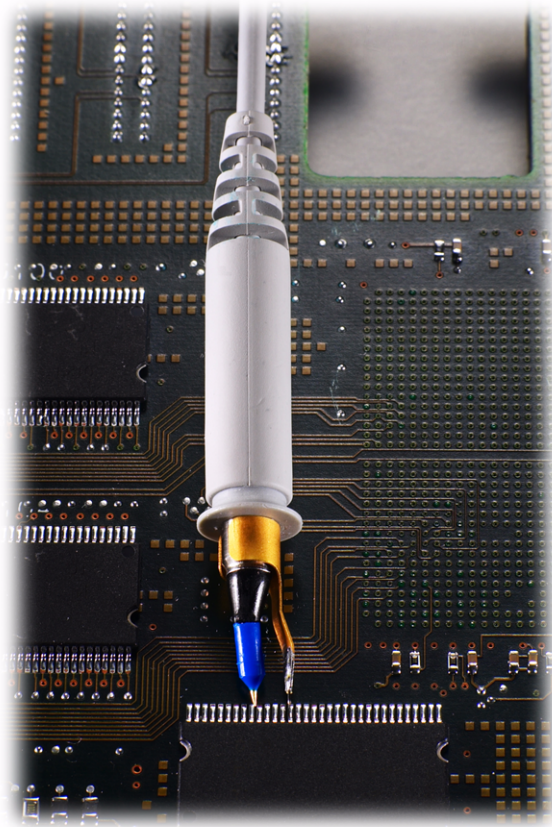

Differential and Single-ended Probe Configurations Other Configurations Overview

12th Choice: Socketed Differential Probe Head with damped wire accessory

This configuration has a bandwidth approximately equal to 1.2 GHz (see the graphs starting on page 2-56). This configuration consists of the following parts:

- E2678A — Socketed Differential Probe Head
- 01130-21302 — 160 Ω damped wire accessory (2 each)

Figure 2-17

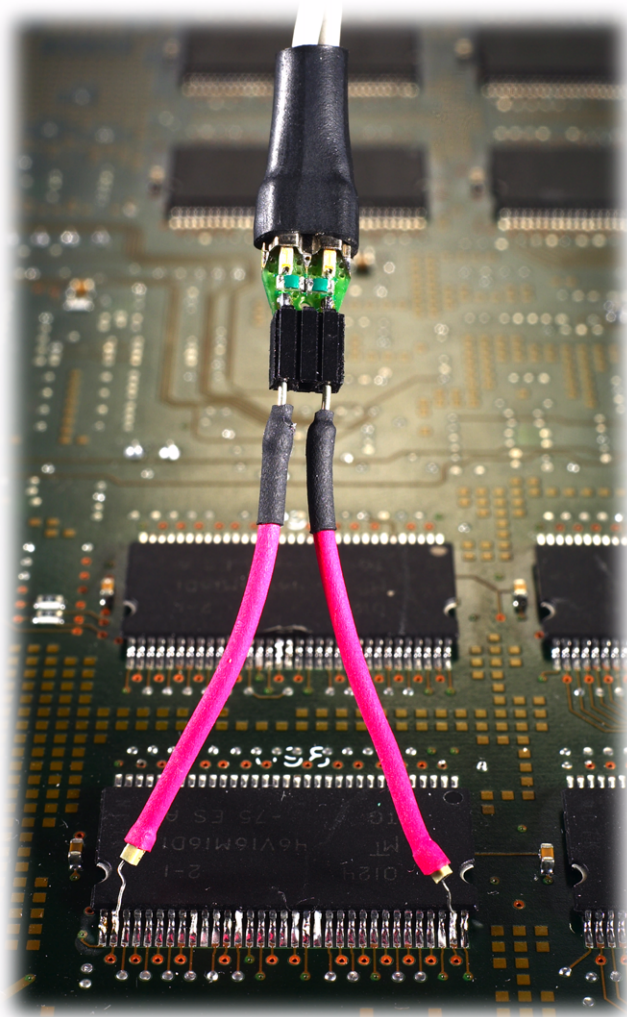

Detailed Information for Recommended Configurations

This section contains graphs of the performance characteristics of the 1168A and 1169A active probes using the different probe heads that come with the N5381A, N5382A, N5380A, N5425A, and N5451A kits.

Differential and Single-ended Probe Configurations
1 N5381A Solder-in Differential Probe Head (Full Bandwidth) and 2 N5382A Differential Browser Probe Head (Full Bandwidth)

1 N5381A Solder-in Differential Probe Head (Full Bandwidth) and 2 N5382A Differential Browser Probe Head (Full Bandwidth)

Unless otherwise noted, time and frequency responses shown here are for the probe only. When the probe is used with the 80000 series oscilloscope, magnitude and phase correction can be applied to further optimize the overall response.

Figure 2-18

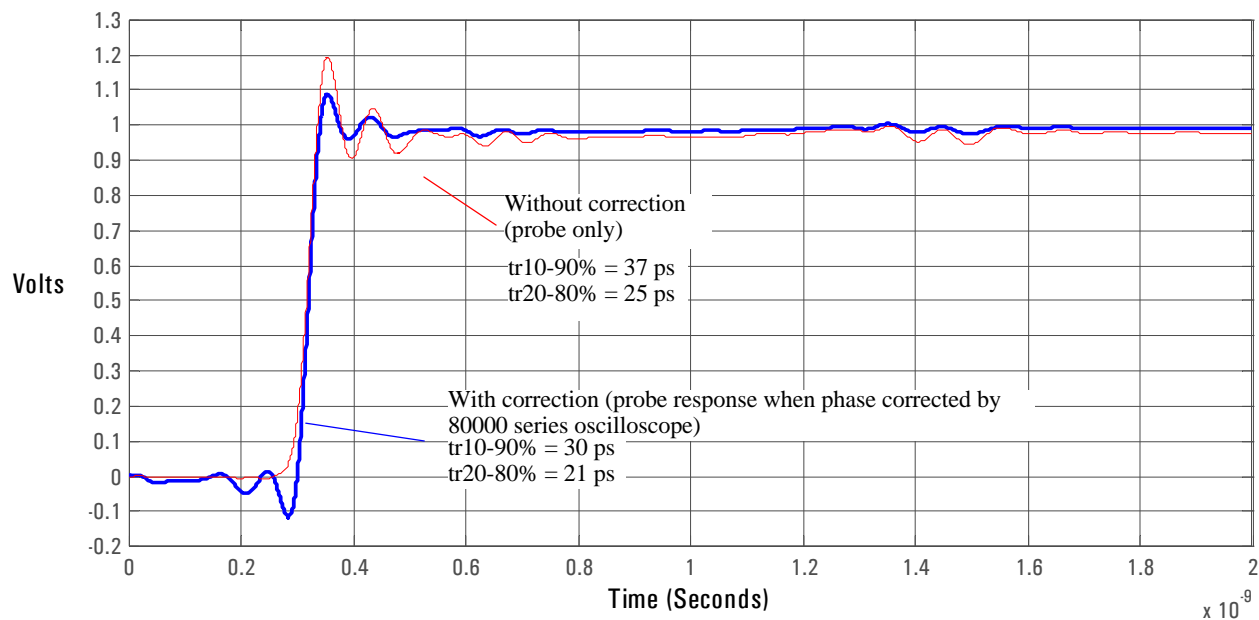

Graph of step response with and without phase correction. Normalized to an ideal input step.

Figure 2-19

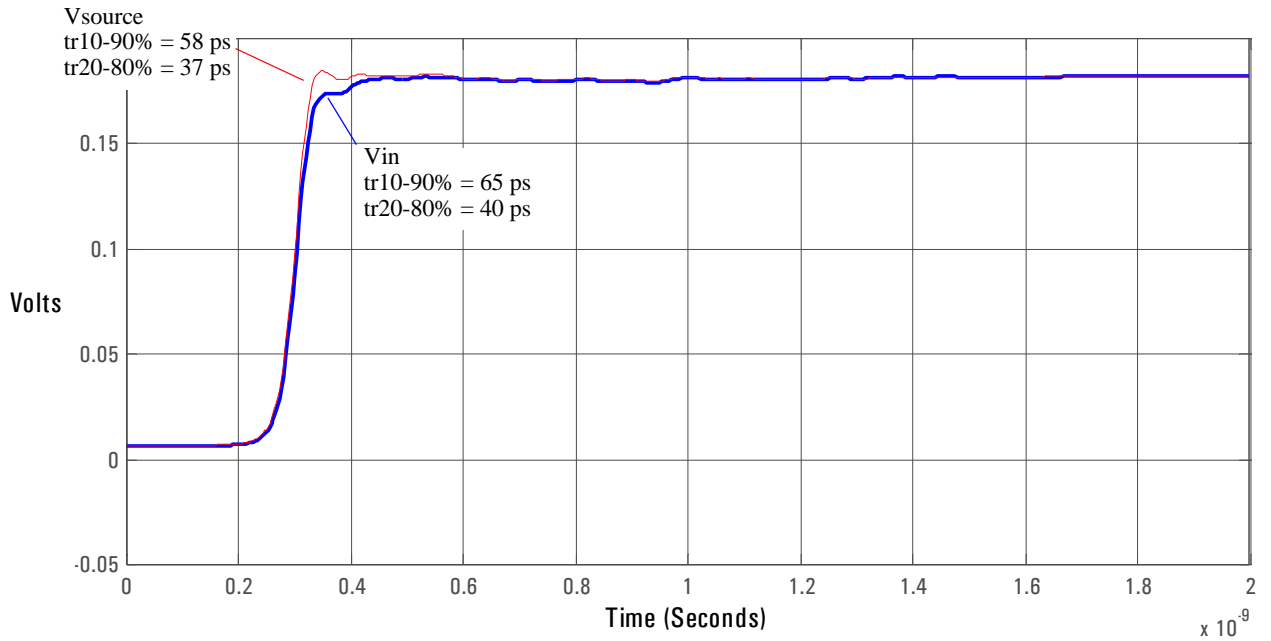

Graph of 25 Ω 58 ps step generator with and without probe connected.

Figure 2-20

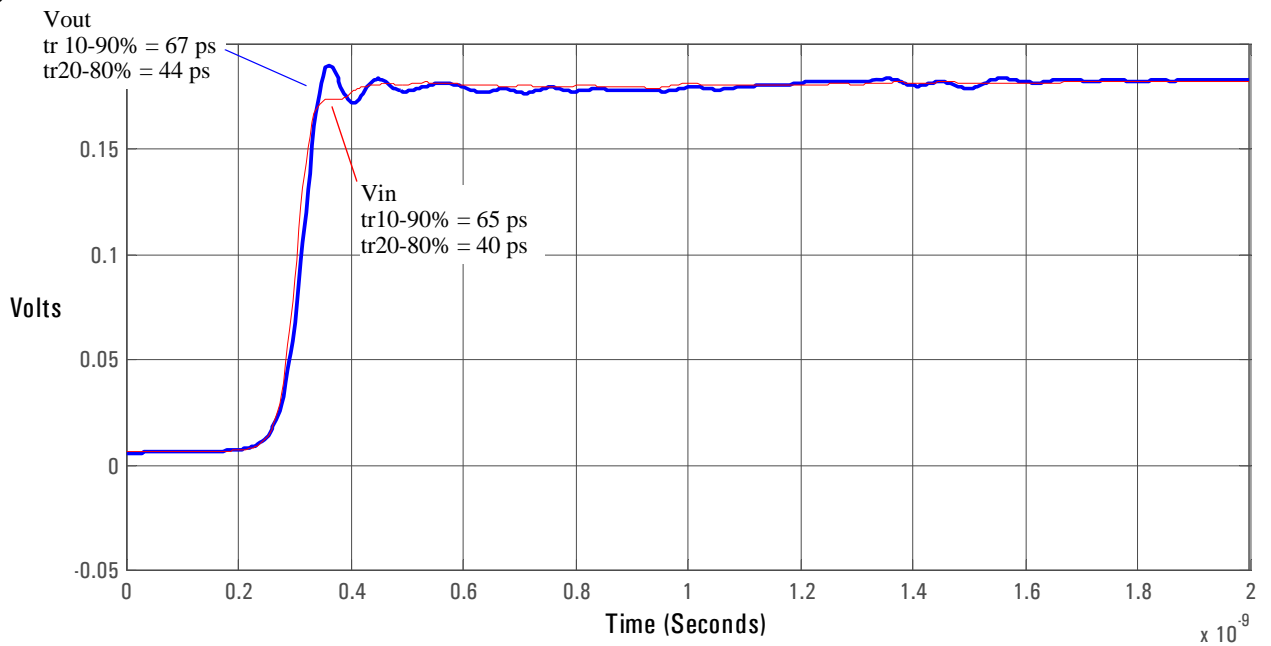

Graph of V_{in} and V_{out} of probe with a 25 Ω 58 ps step generator.

Differential and Single-ended Probe Configurations
1 N5381A Solder-in Differential Probe Head (Full Bandwidth) and 2 N5382A Differential Browser
Probe Head (Full Bandwidth)

Figure 2-21

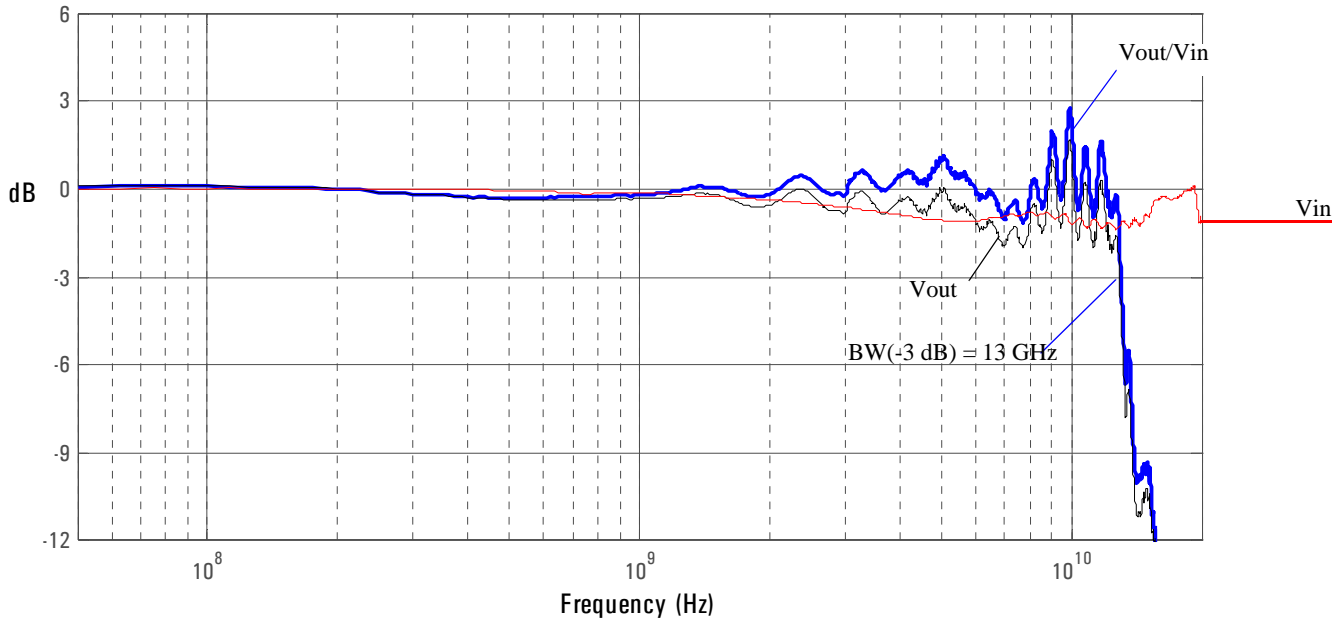

Graph of $\text{dB}(V_{in})$ and $\text{dB}(V_{out}) + 10.8\text{ dB}$ of probe with a $25\ \Omega$ source and $\text{dB}(V_{out}/V_{in}) + 10.8\text{ dB}$ frequency response.

Figure 2-22

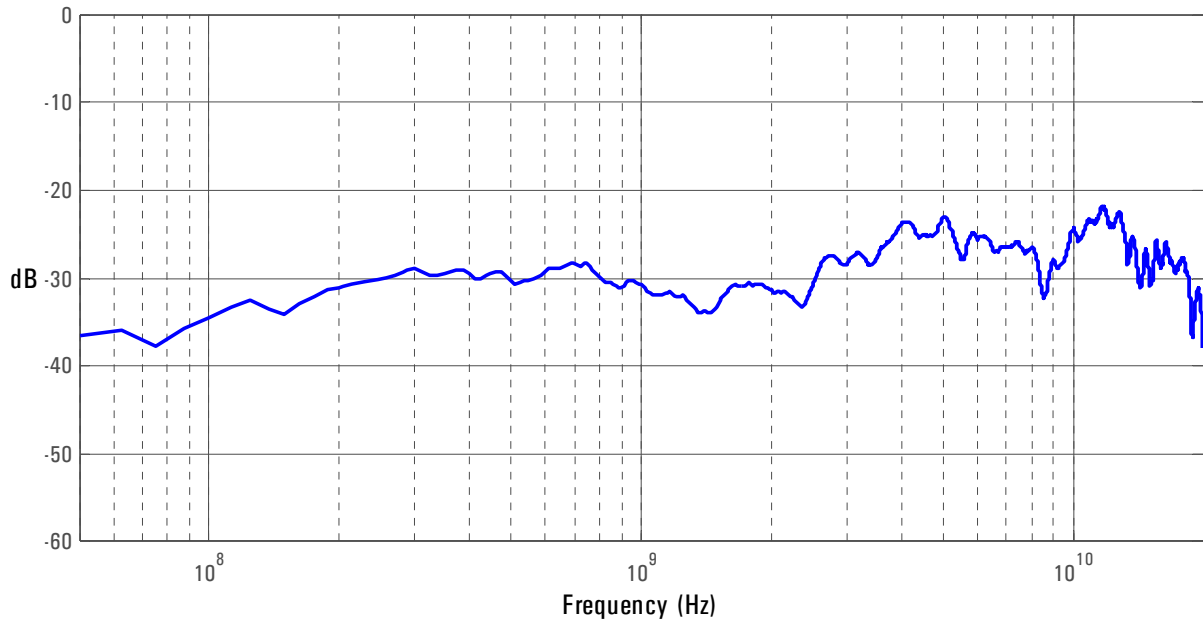

Graph of $\text{dB}(V_{out}/V_{in}) + 10.8\text{ dB}$ frequency response when inputs driven in common (common mode rejection).

Figure 2-23

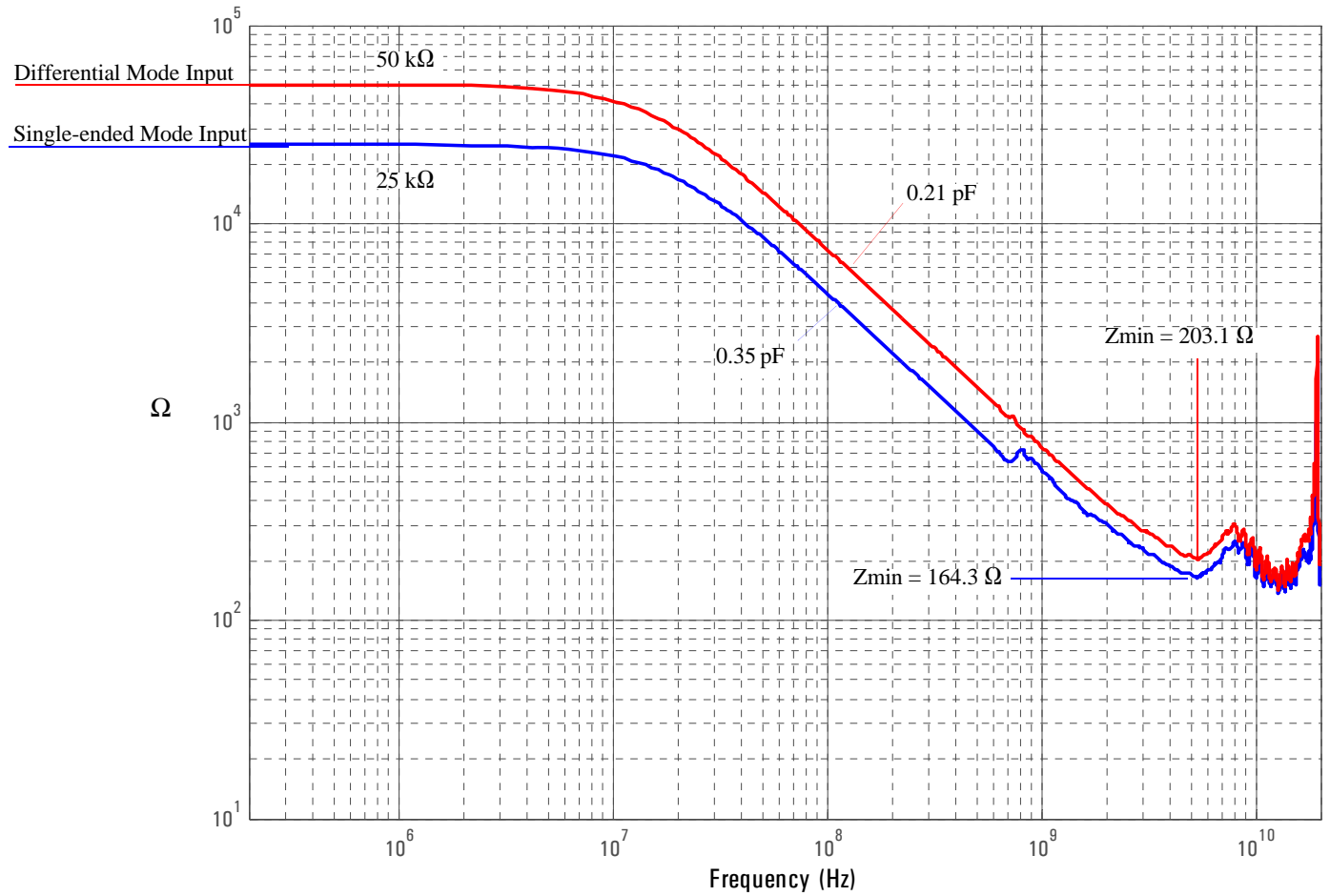

Magnitude plot of probe input impedance versus frequency.

3 N5380A SMA Probe Head (Full Bandwidth)

Unless otherwise noted, time and frequency responses shown here are for the probe only. when the probe is used with the 80000 series oscilloscope, magnitude and phase correction is applied to further optimize the overall response.

Figure 2-24

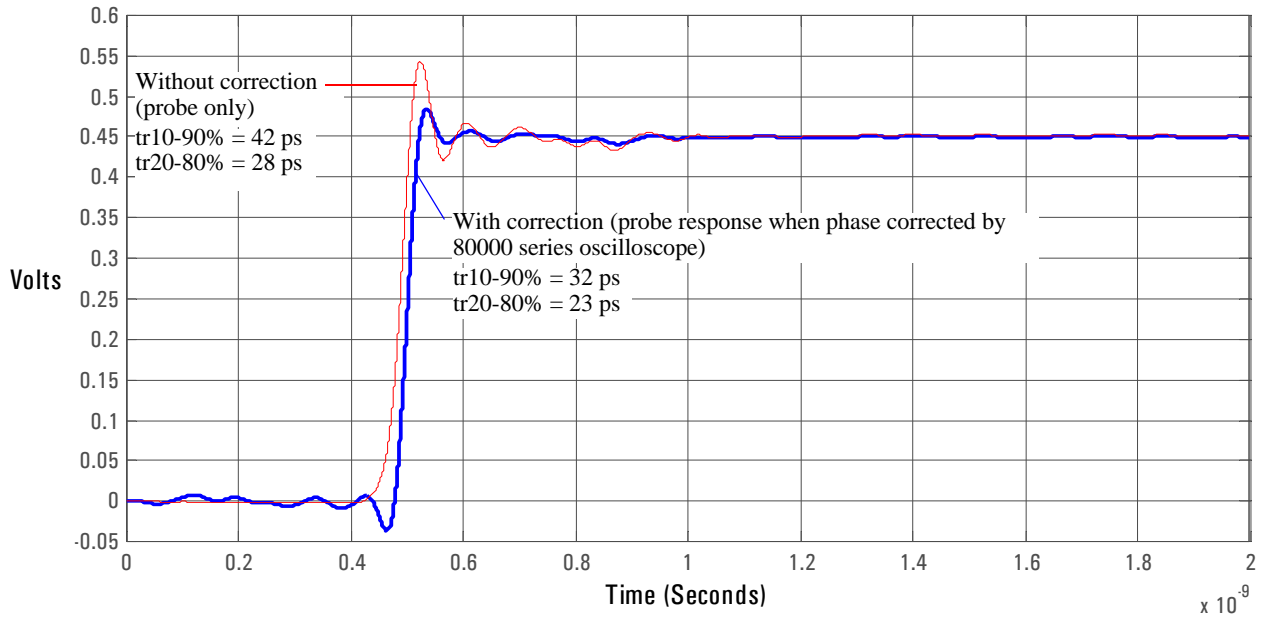

Graph of step response with and without phase correction. Normalized to an ideal input step.

Figure 2-25

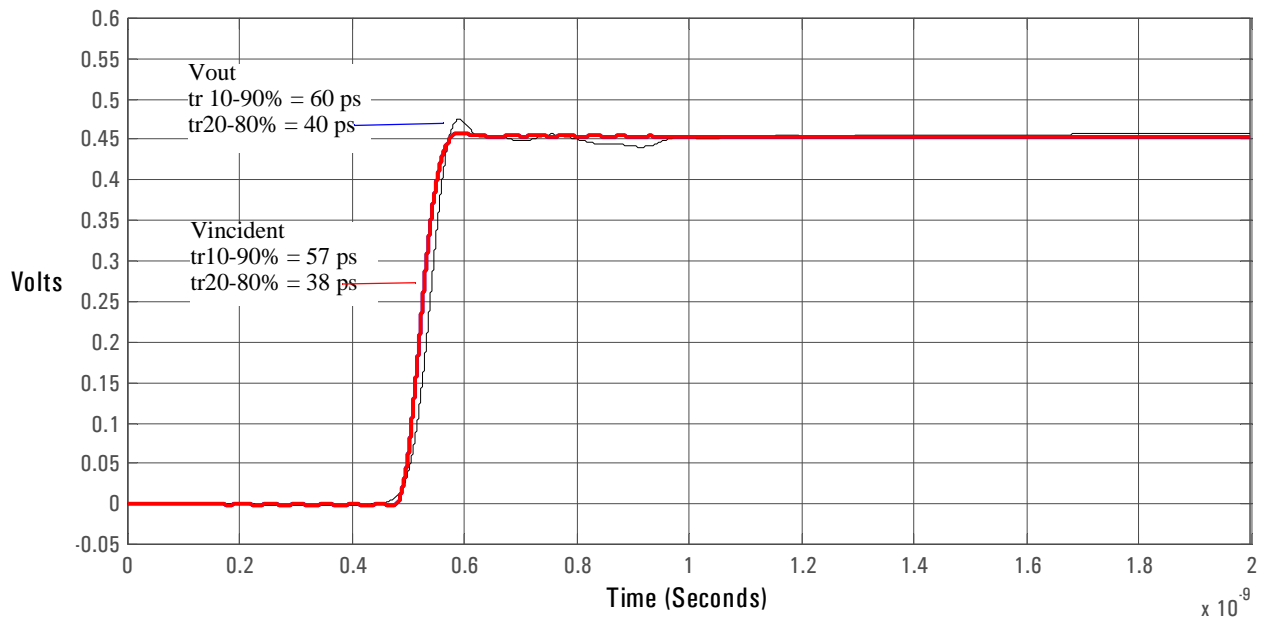

Graph of Vincident and Vout of probe with a 57 ps step.

Figure 2-26

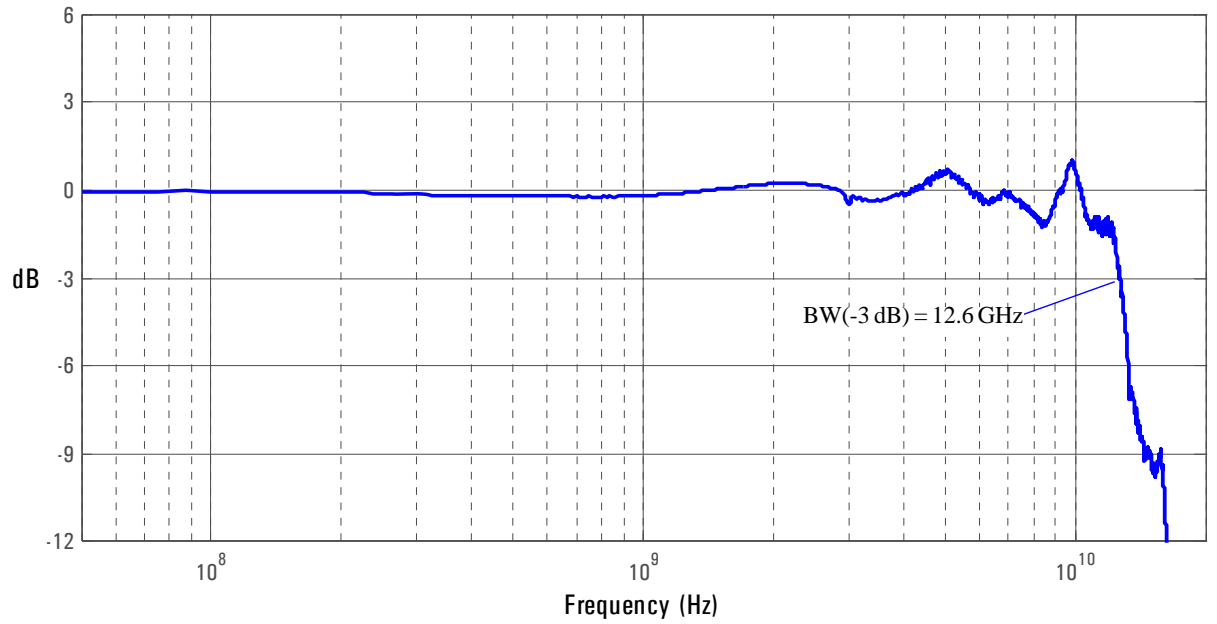

Magnitude plot of differential insertion loss +6.8 dB.

Figure 2-27

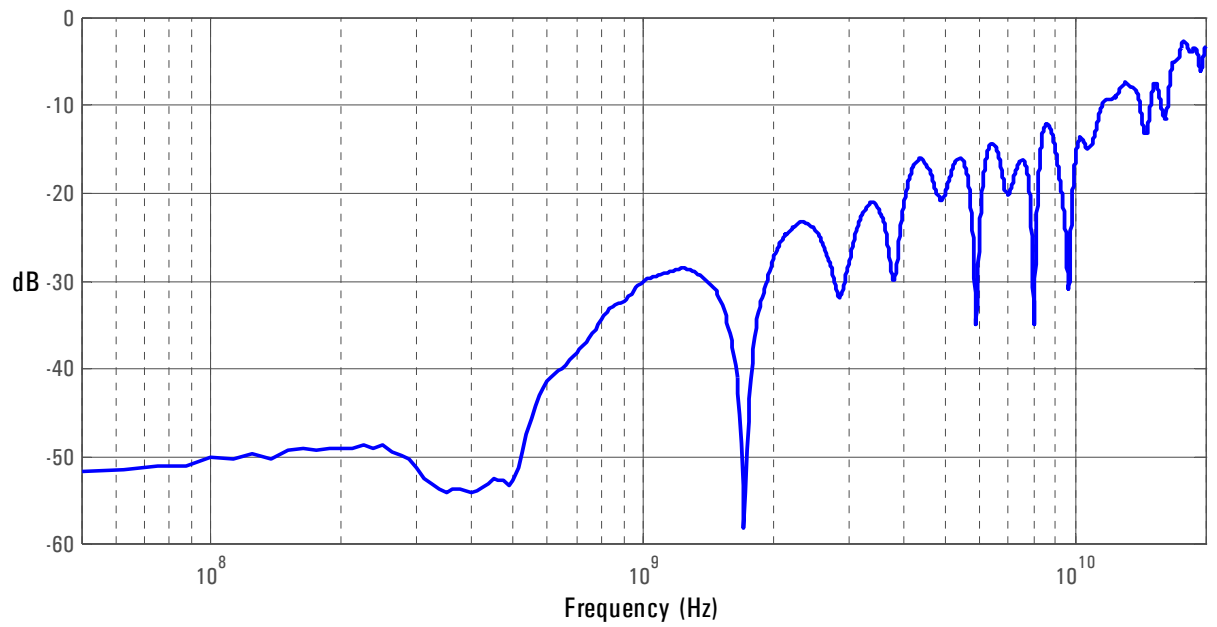

Magnitude plot of differential return loss.

Differential and Single-ended Probe Configurations
3 N5380A SMA Probe Head (Full Bandwidth)

Figure 2-28

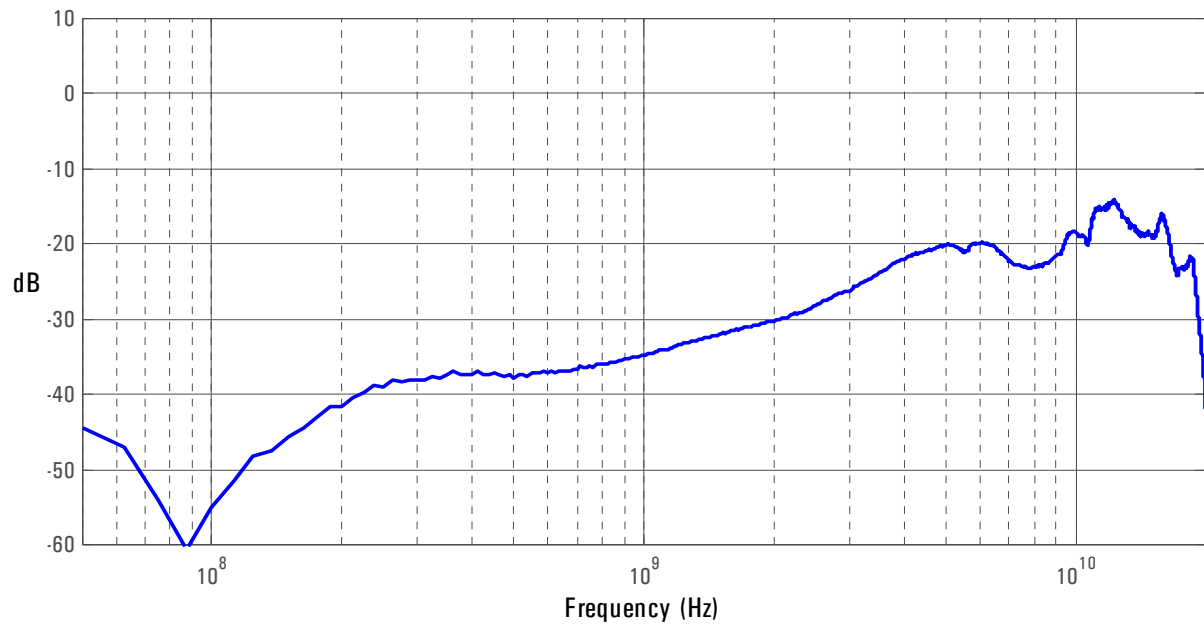

Magnitude plot of common mode response +6.8dB (common mode rejection).

4 N5425A ZIF Probe Head (Full Bandwidth)

Unless otherwise noted, time and frequency responses shown here are for the probe only. when the probe is used with the 80000 series oscilloscope, magnitude and phase correction is applied to further optimize the overall response.

Figure 2-29

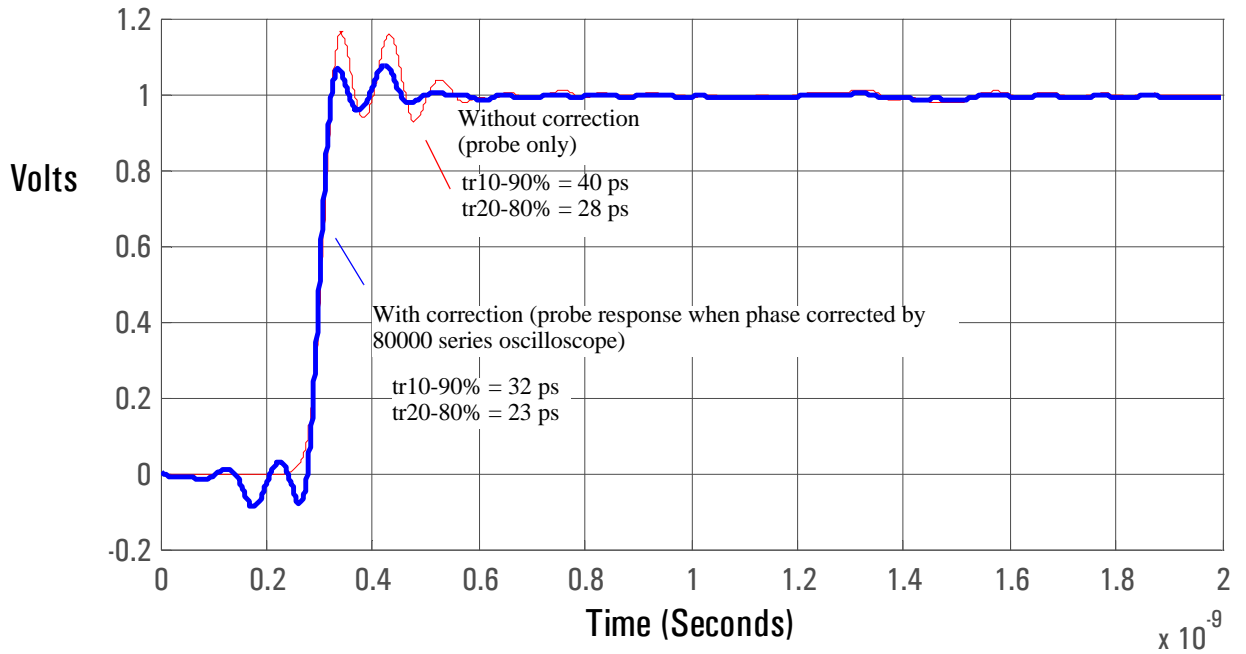

Graph of step response with and without phase correction. Normalized to an ideal input step.

Figure 2-30

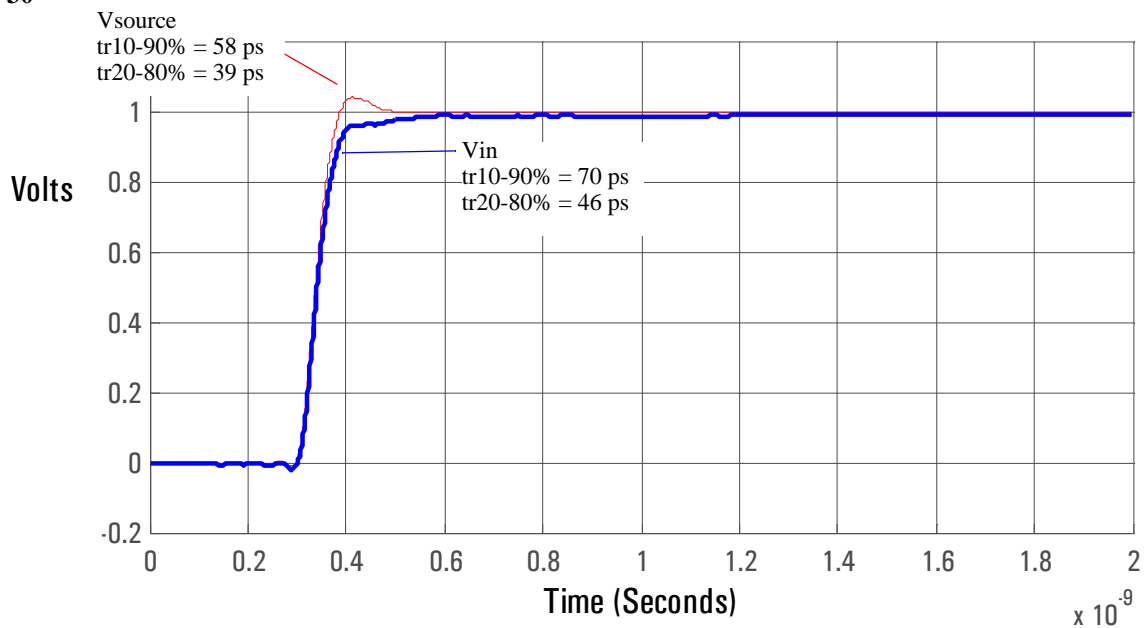

Graph of a 25 Ω 58 ps step with and without the probe connected.

Differential and Single-ended Probe Configurations
 4 N5425A ZIF Probe Head (Full Bandwidth)

Figure 2-31

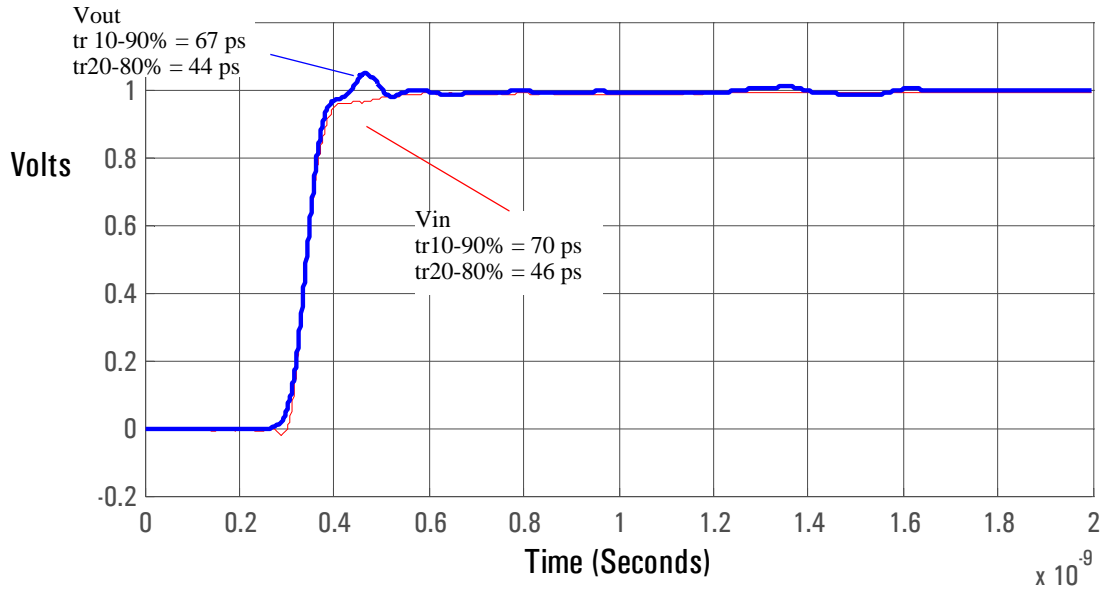

Graph of Vin and Vout of probe with a 25 Ω 58 ps step.

Figure 2-32

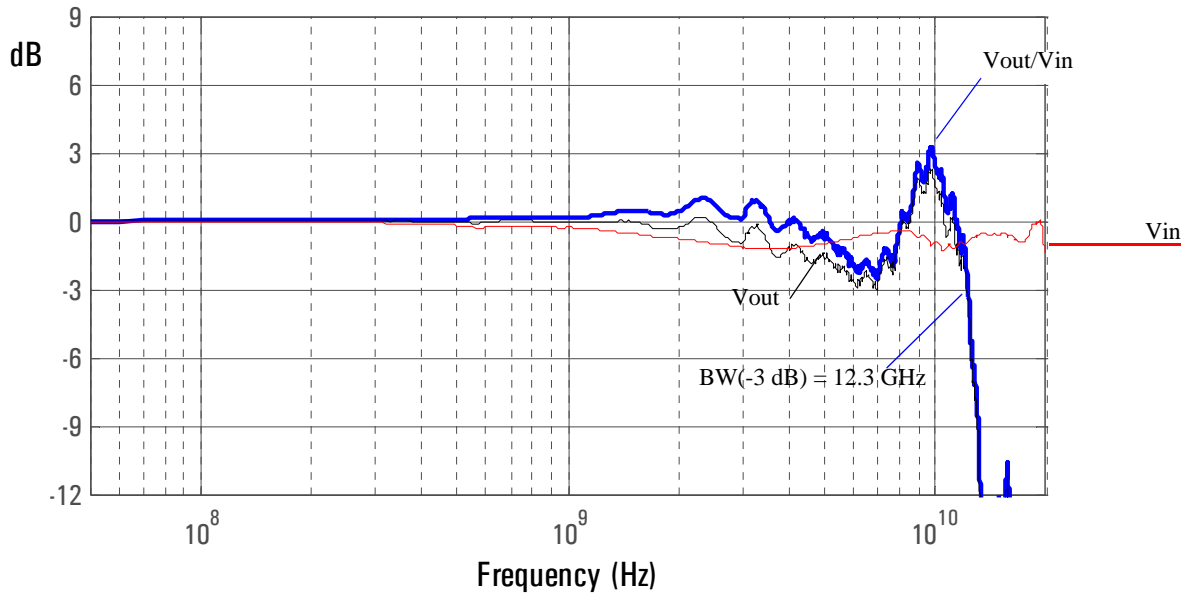

Graph of dB(Vin) and dB(Vout) + 10.8 dB of probe with a 25 Ω source and dB(Vout/Vin) + 10.8 dB frequency response.

Figure 2-33

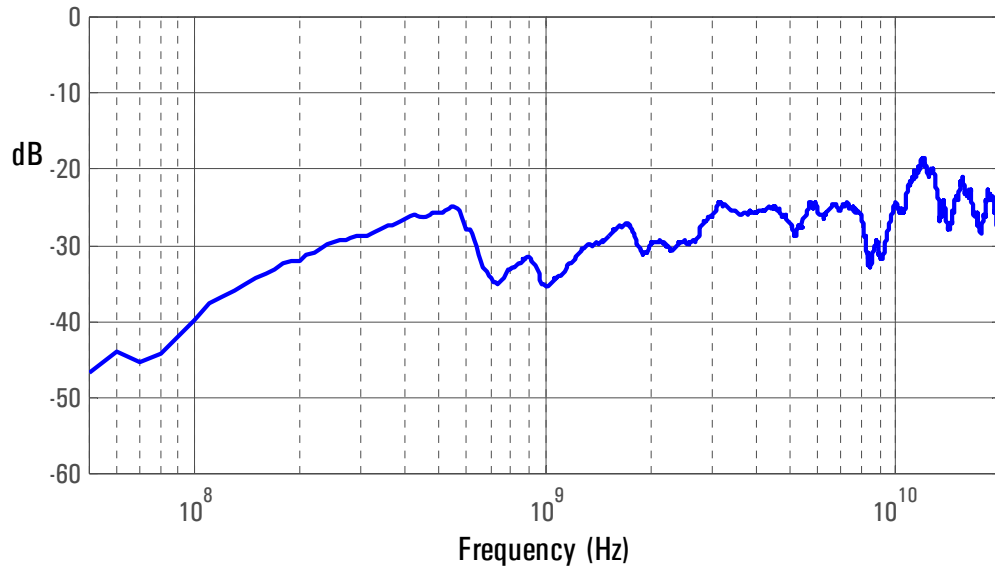

Graph of $\text{dB}(V_{\text{out}}/V_{\text{in}}) + 10.8 \text{ dB}$ frequency response when inputs driven in common (common mode rejection).

Figure 2-34

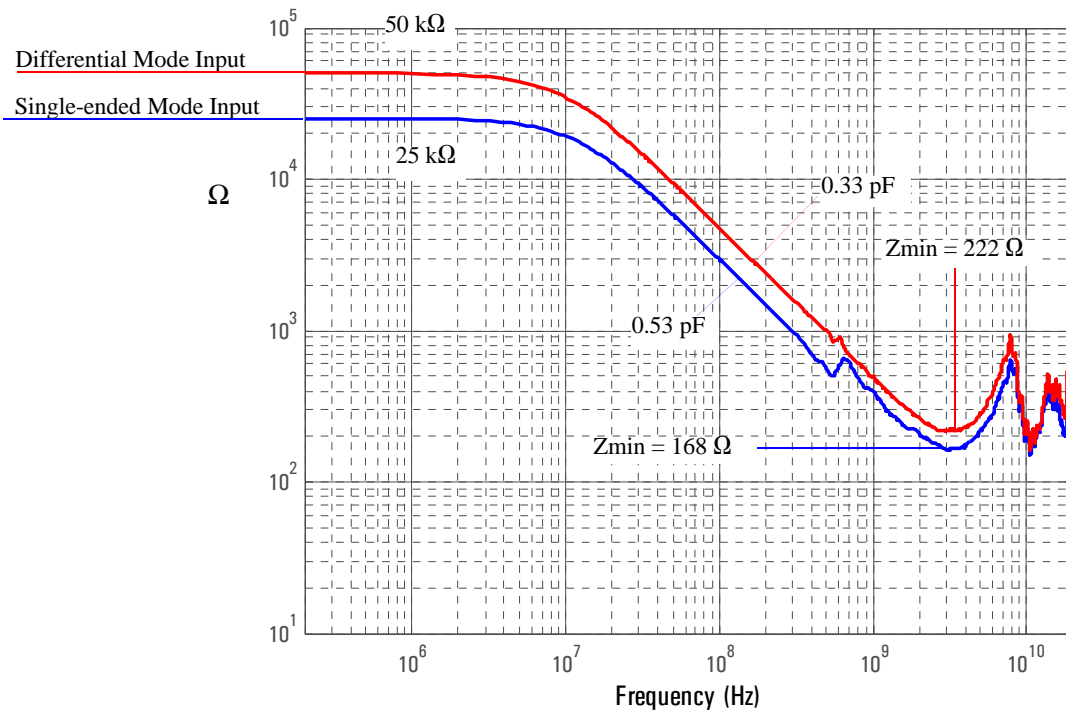

Magnitude plot of probe input impedance versus frequency.

Differential and Single-ended Probe Configurations 4 N5425A ZIF Probe Head (Full Bandwidth)

ZIF Probe Head Accessory Impedance (N5426A)

The impedance plot shown in Figure 2-35 is of the ZIF probe head accessory without the probe head connected.

Figure 2-35

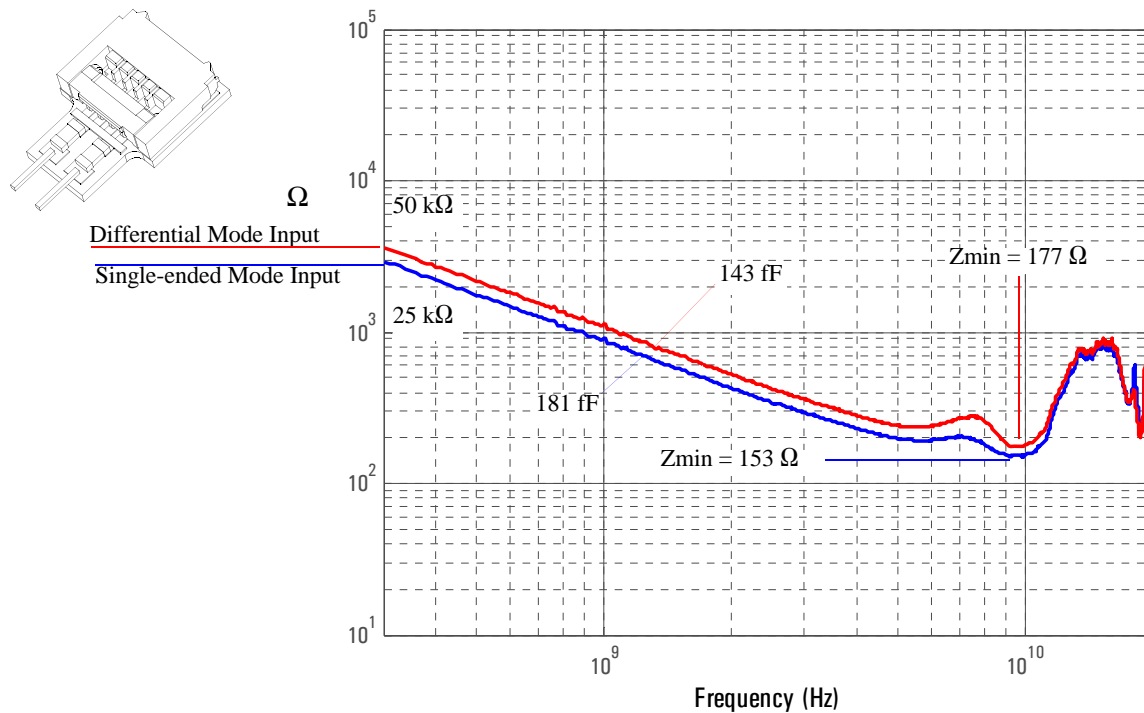

Magnitude plot of accessory input impedance versus frequency.

5 and 6 ZIF Probe Head with N5451A Long-Wired ZIF Tip

Unless otherwise noted, time and frequency responses shown here are for the probe only. When the probe is used with the 80000 series oscilloscope, magnitude and phase correction is applied to further optimize the overall response.

Plots for 7 mm Lead Length and Zero Degrees of Separation Between the Resistor Leads

Figure 2-36

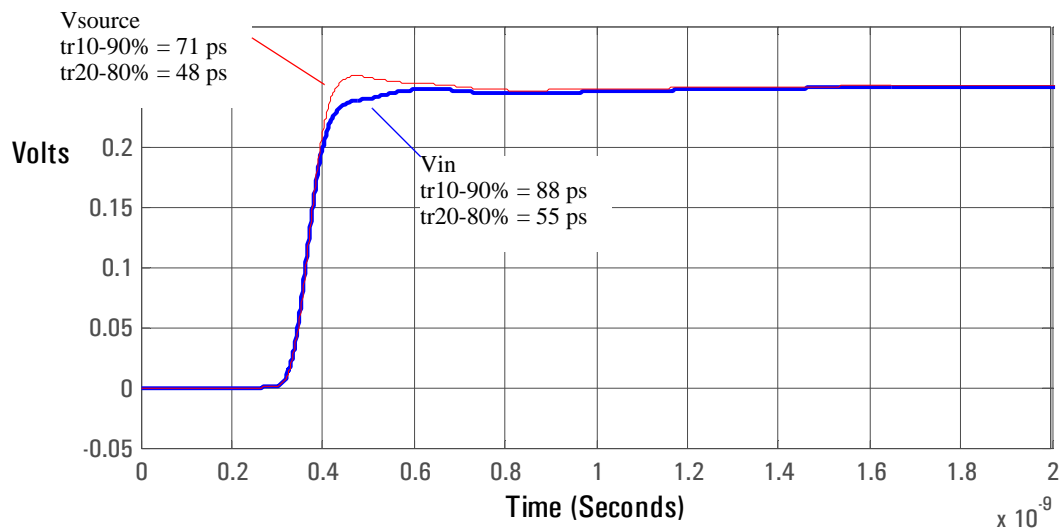

Graph of a 25 Ω 71 ps step generator with and without the probe connected.

Figure 2-37

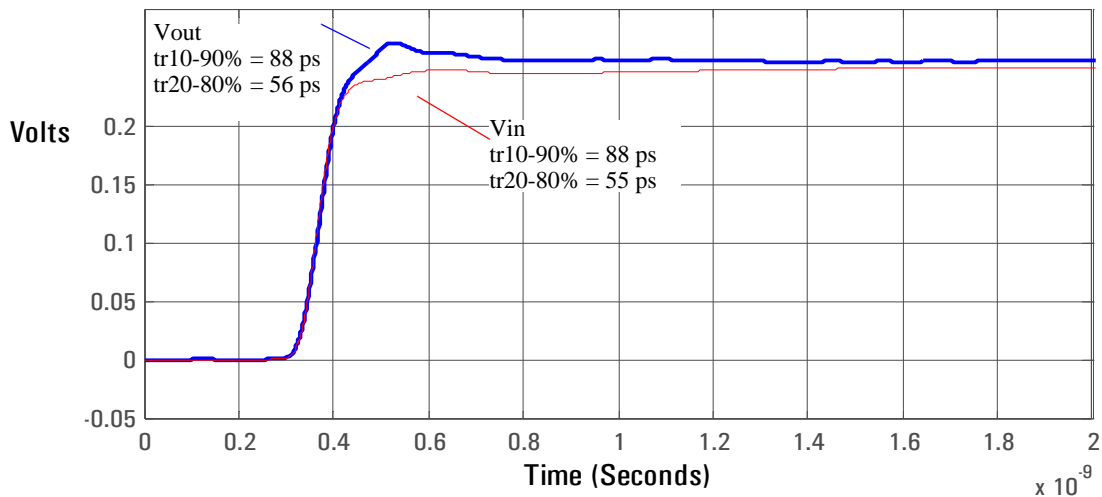

Graph of V_{in} and V_{out} of probe with a 25 Ω 71 ps step generator.

Differential and Single-ended Probe Configurations
5 and 6 ZIF Probe Head with N5451A Long-Wired ZIF Tip

Figure 2-38

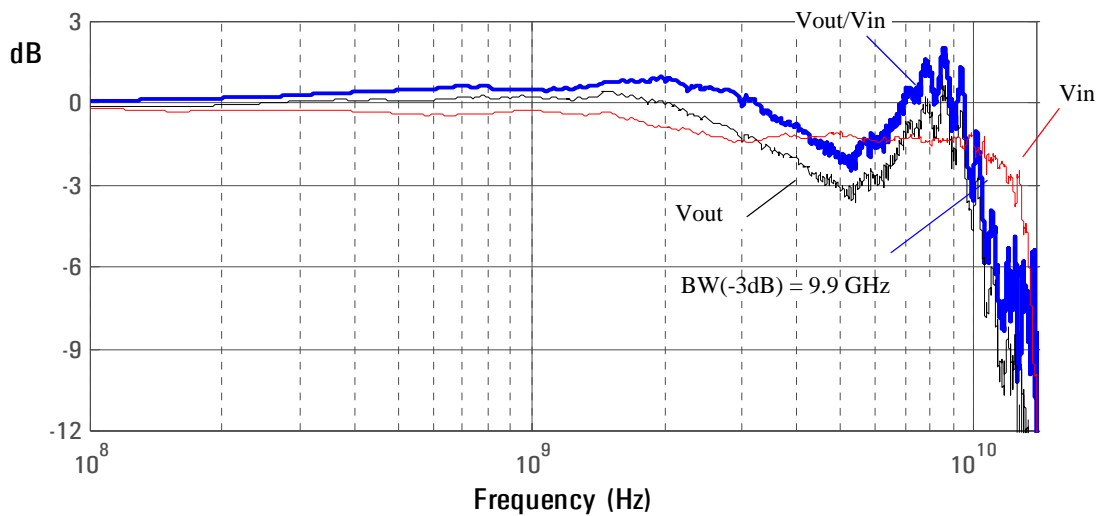

Graph of $dB(V_{in})$ and $dB(V_{out}) + 10.8\text{ dB}$ of probe with a $25\ \Omega$ source and $dB(V_{out}/V_{in}) + 10.8\text{ dB}$ frequency response.

Figure 2-39

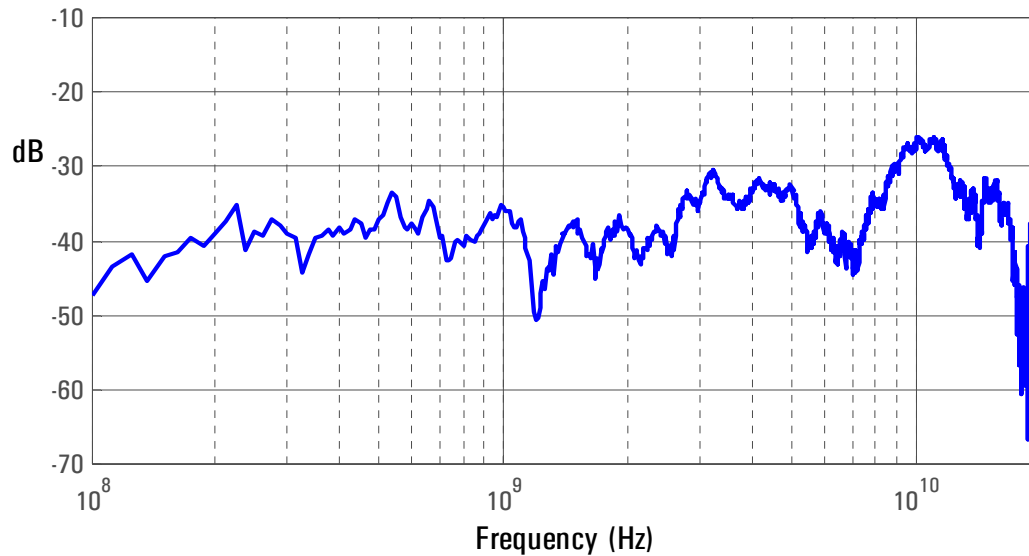

Graph of $dB(V_{out}/V_{in}) + 10.8\text{ dB}$ frequency response when inputs driven in common (common mode rejection).

Figure 2-40

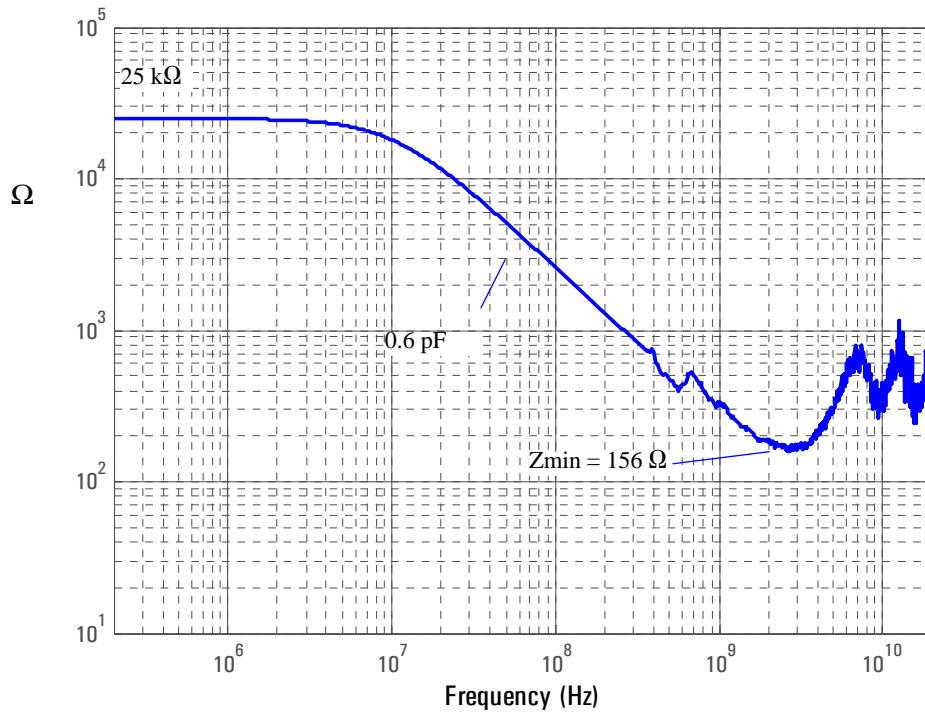

Magnitude plot of probe input impedance versus frequency (single ended mode input).

Plots for 7 mm Lead Length and Sixty Degrees of Separation between the Resistor Leads

Figure 2-41

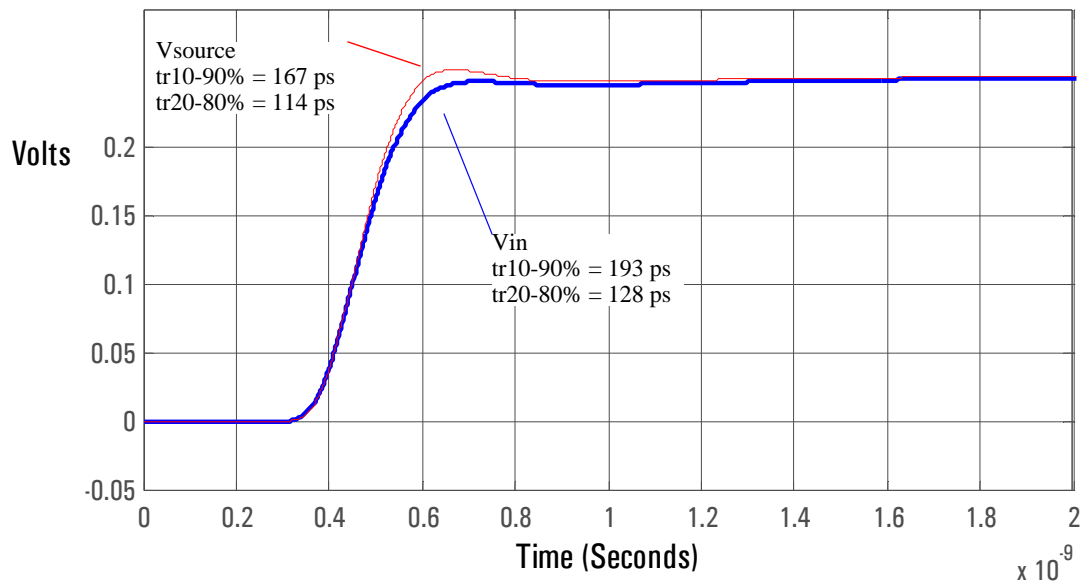

Graph of a $25\ \Omega$ 167 ps step generator with and without the probe connected.

Differential and Single-ended Probe Configurations
5 and 6 ZIF Probe Head with N5451A Long-Wired ZIF Tip

Figure 2-42

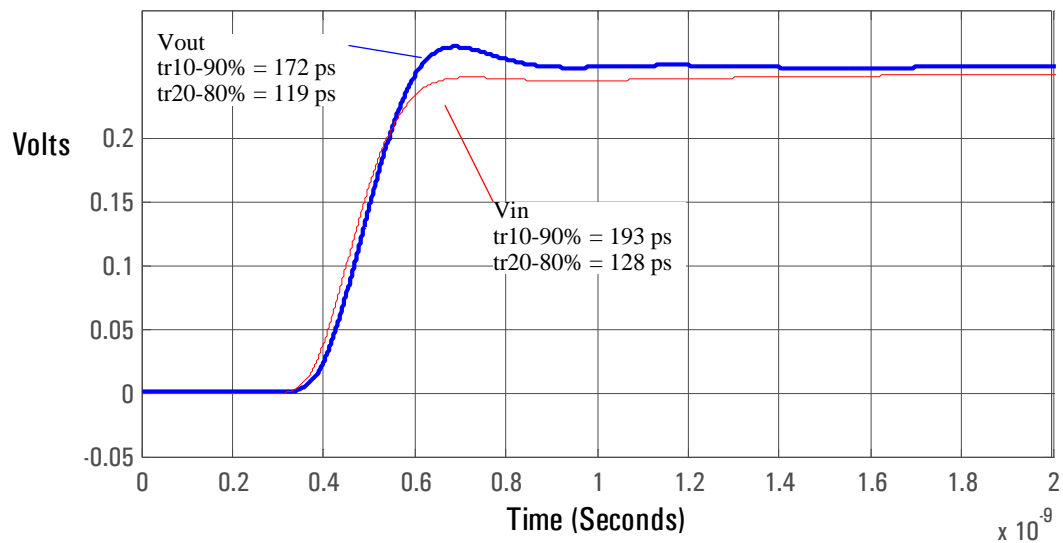

Graph of Vout and Vin of probe with a 25 Ω 167 ps step generator.

Figure 2-43

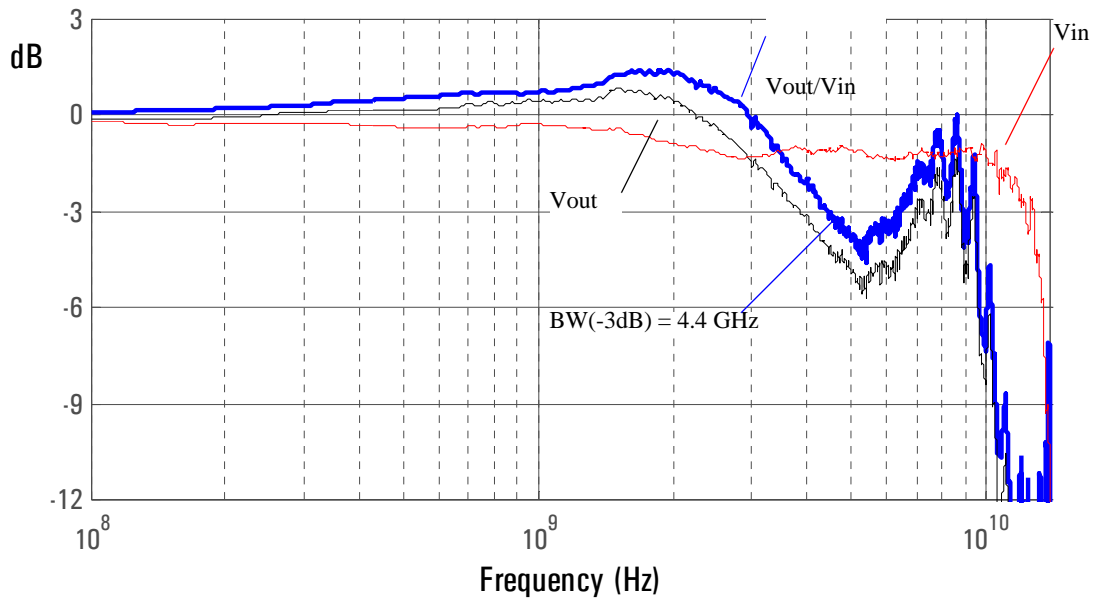

Graph of dB(Vin) and dB(Vout) + 10.8 dB of probe with a 25 Ω source and dB(Vout/Vin) + 10.8 dB frequency response.

Figure 2-44

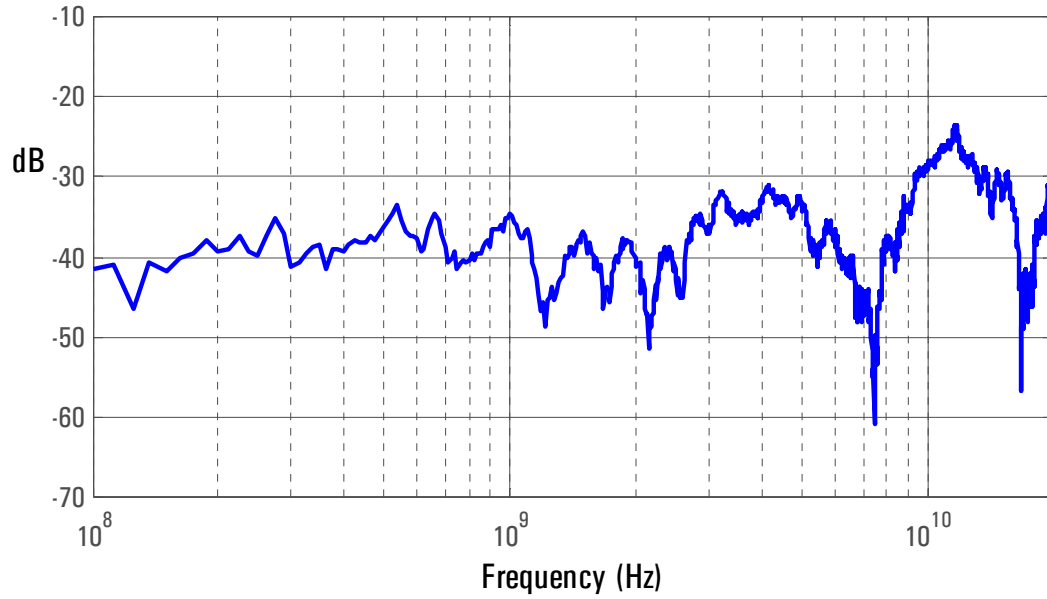

Graph of $\text{dB}(V_{\text{out}}/V_{\text{in}}) + 10.8$ dB frequency response when inputs driven in common (common mode rejection).

Figure 2-45

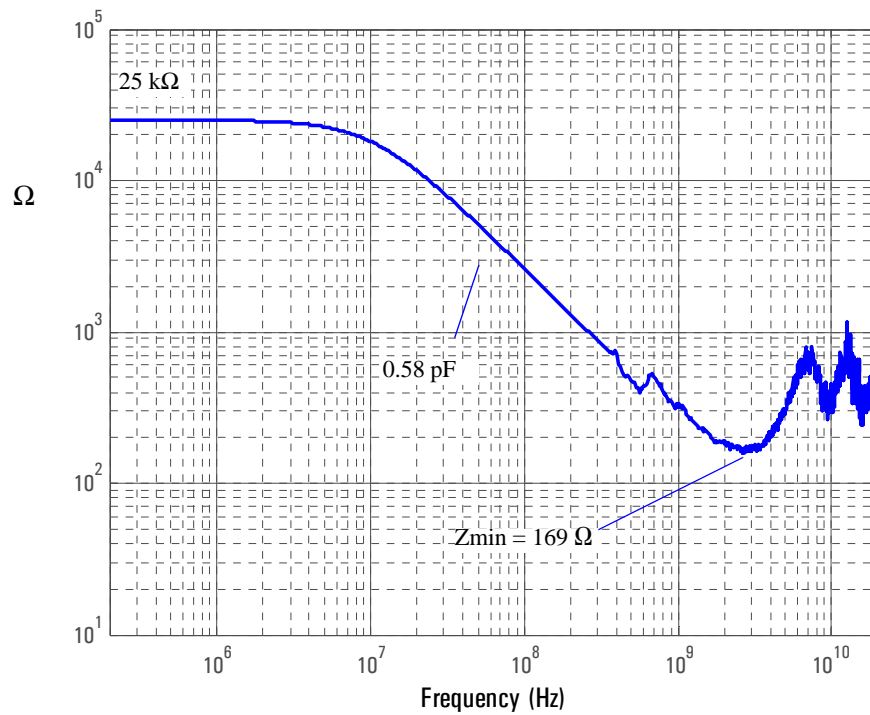

Magnitude plot of probe input impedance versus frequency (single-ended mode input).

Plots for 11 mm Lead Length and Zero Degrees of Separation Between the Resistor Leads

Figure 2-46

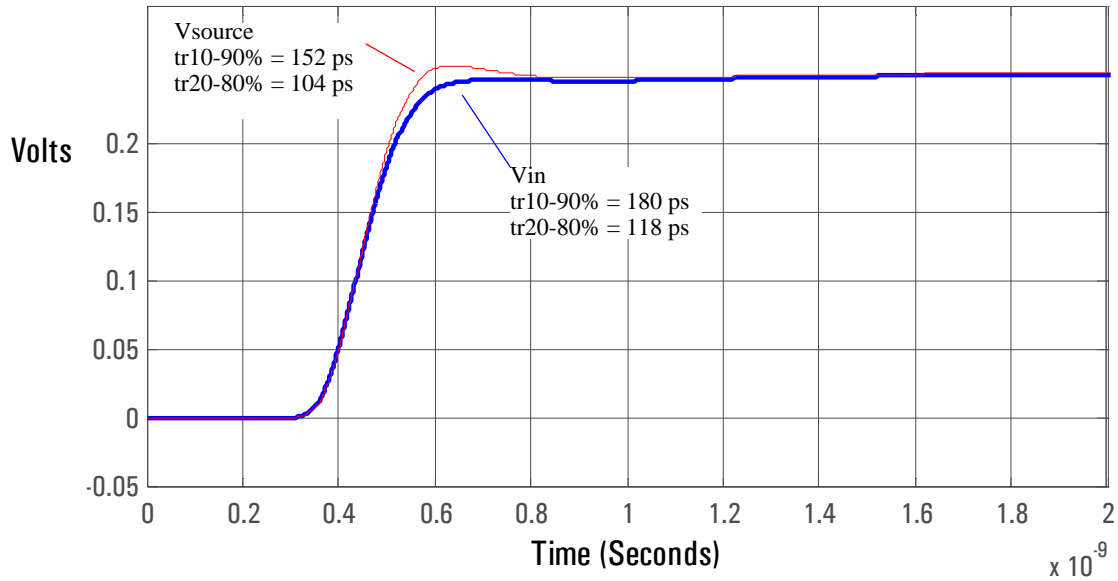

Graph of 25 Ω 152 ps step generator with and without the probe connected.

Figure 2-47

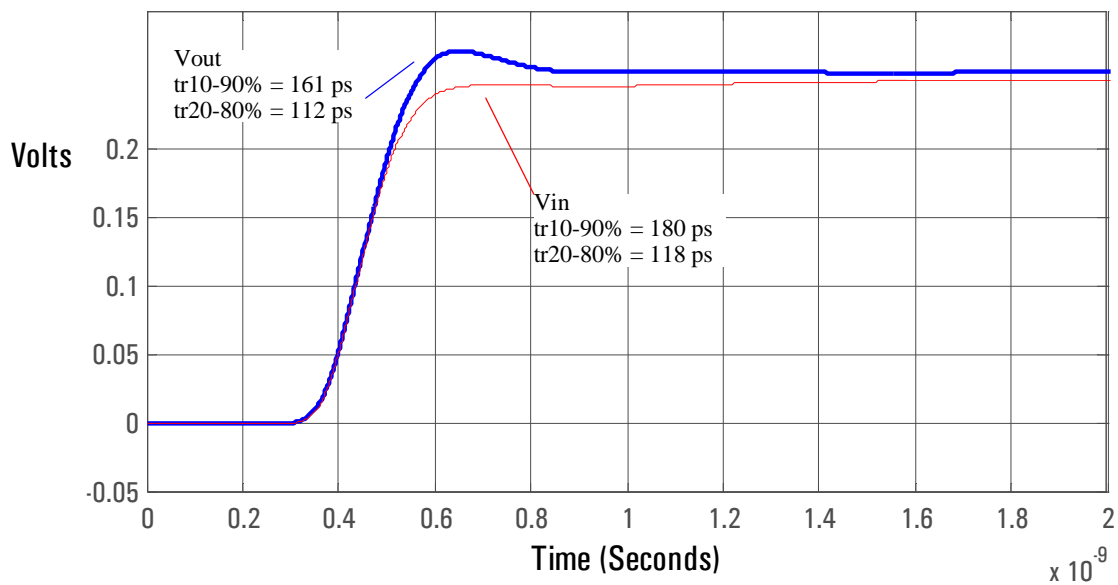

Graph of V_{in} and V_{out} of probe with a 25 Ω 152 ps step generator.

Figure 2-48

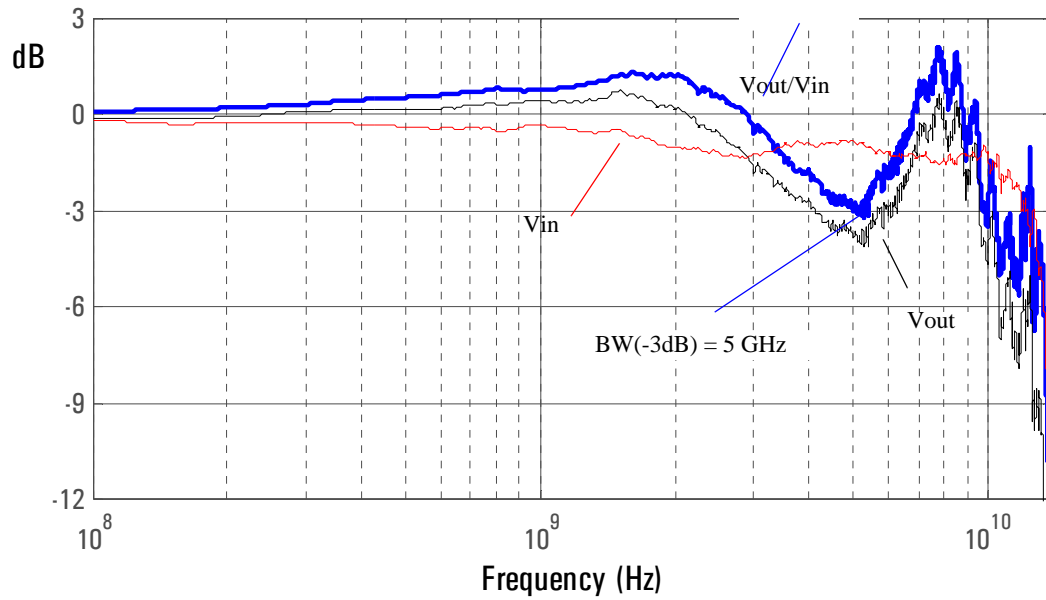

Graph of $\text{dB}(V_{in})$ and $\text{dB}(V_{out}) + 10.8 \text{ dB}$ of probe with a 25Ω source and $\text{dB}(V_{out}/V_{in}) + 10.8 \text{ dB}$ frequency response.

Figure 2-49

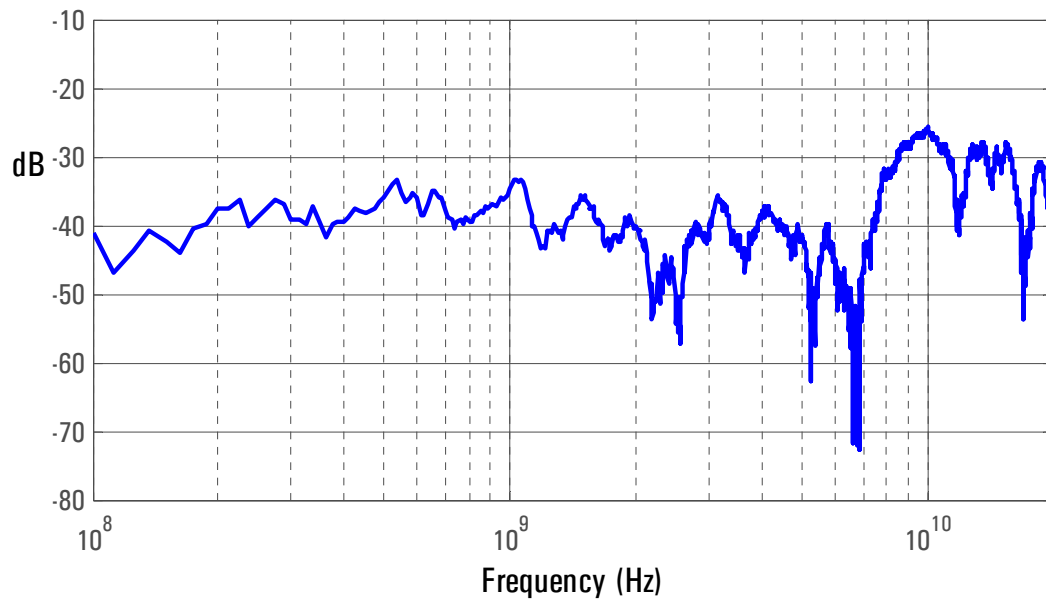

Graph of $\text{dB}(V_{out}/V_{in}) + 10.8 \text{ dB}$ frequency response when inputs driven in common (common mode rejection).

Differential and Single-ended Probe Configurations
5 and 6 ZIF Probe Head with N5451A Long-Wired ZIF Tip

Figure 2-50

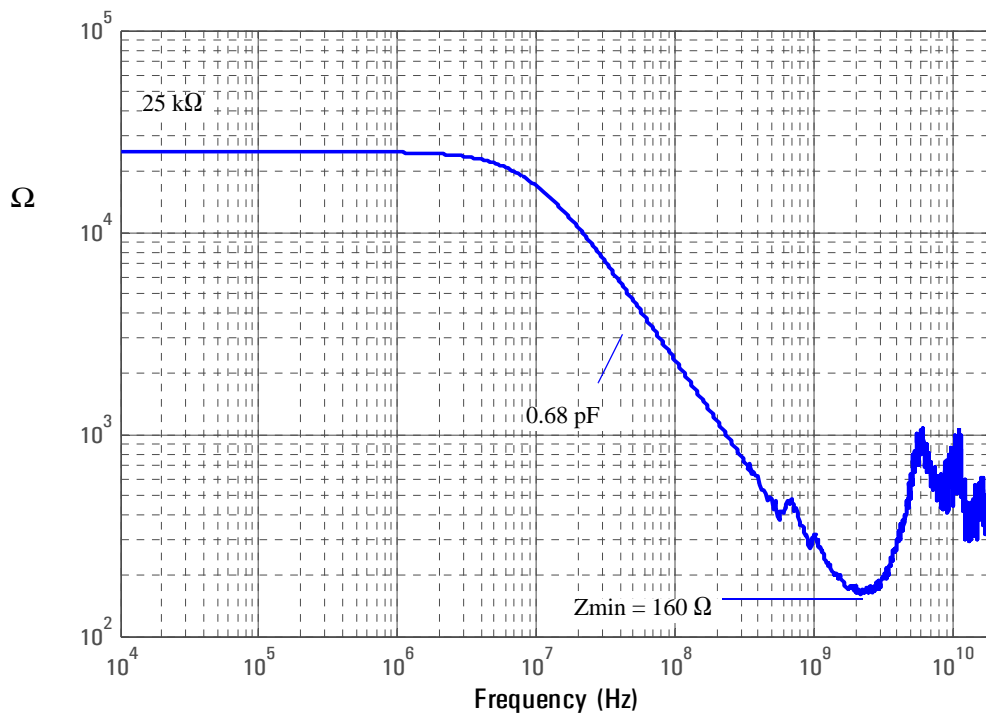

Magnitude plot of probe input impedance versus frequency (single-ended mode input).

Plots for 11 mm Lead Length and Sixty Degrees of Separation between the Resistor Leads

Figure 2-51

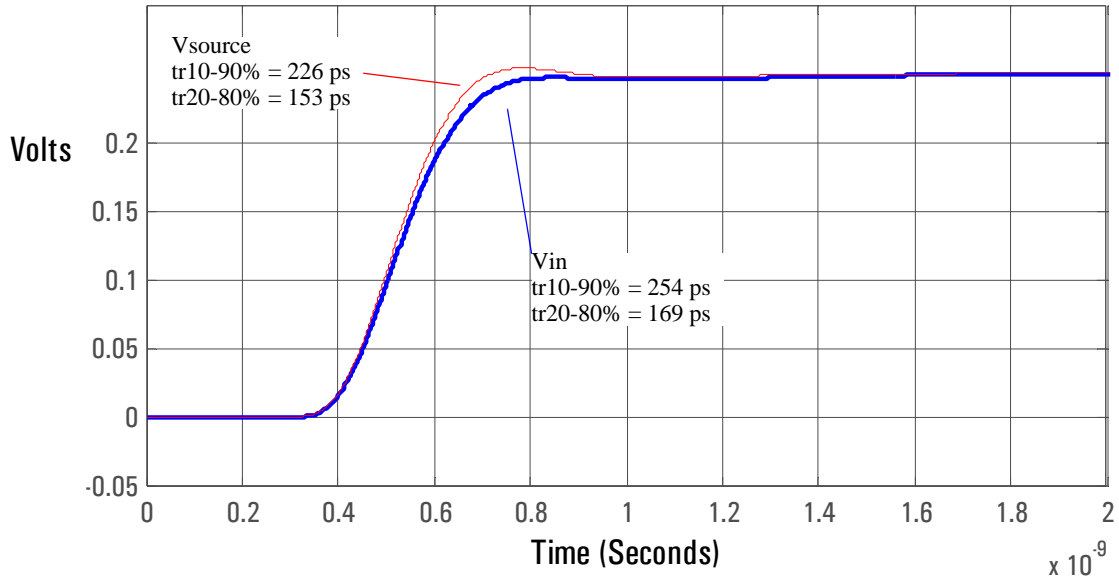

Graph of 25 Ω 226 ps step generator with and without the probe connected.

Figure 2-52

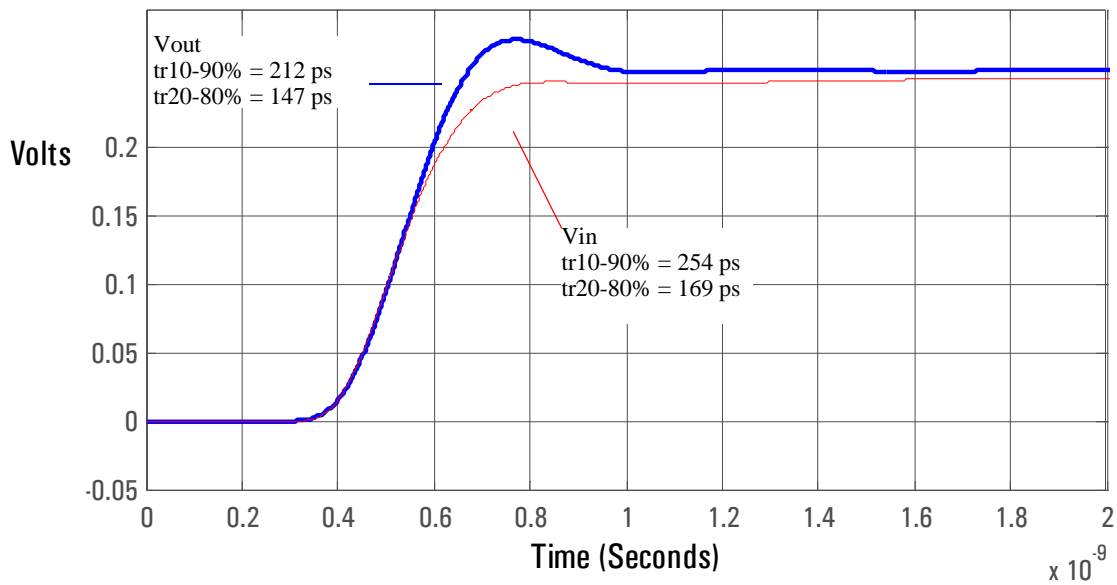

Graph of V_{in} and V_{out} of probe with a 25 Ω 226 ps step generator.

Differential and Single-ended Probe Configurations
5 and 6 ZIF Probe Head with N5451A Long-Wired ZIF Tip

Figure 2-53

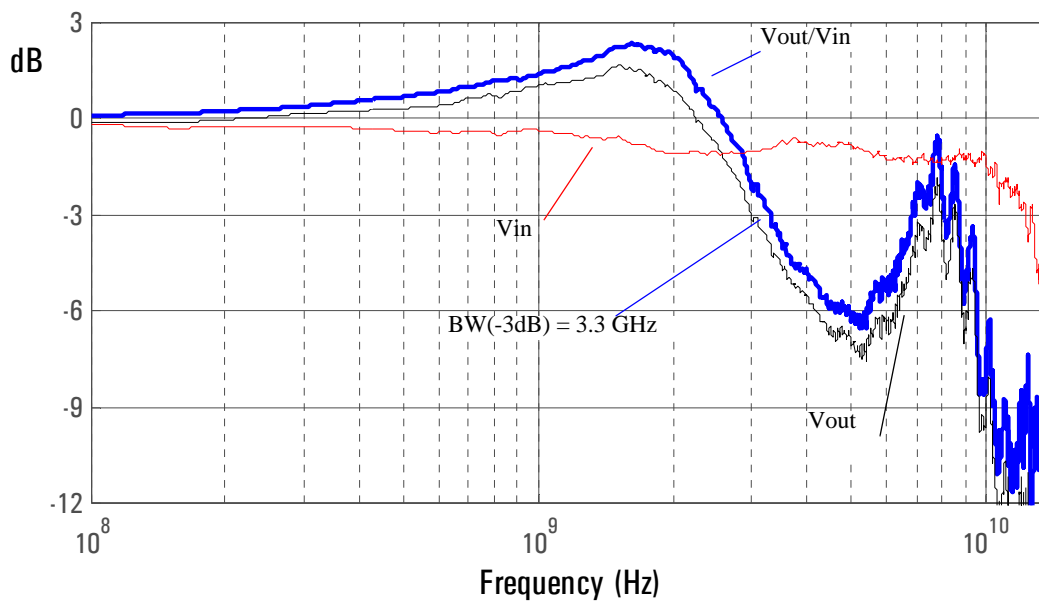

Graph of $\text{dB}(V_{in})$ and $\text{dB}(V_{out}) + 10.8 \text{ dB}$ of probe with a 25Ω source and $\text{dB}(V_{out}/V_{in}) + 10.8 \text{ dB}$ frequency response.

Figure 2-54

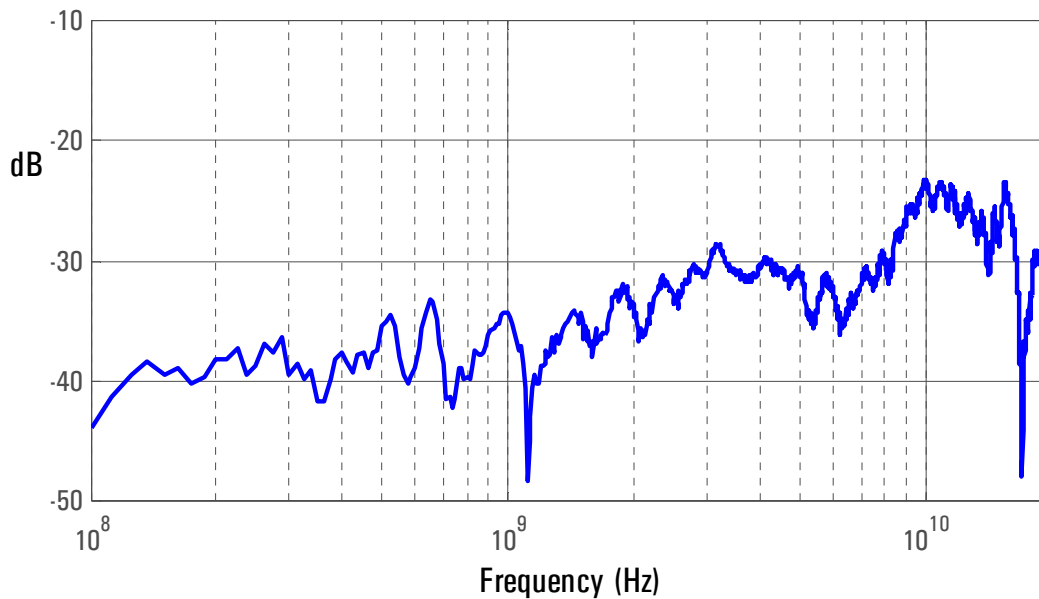

Graph of $\text{dB}(V_{out}/V_{in}) + 10.8 \text{ dB}$ frequency response when inputs driven in common (common mode rejection).

Figure 2-55

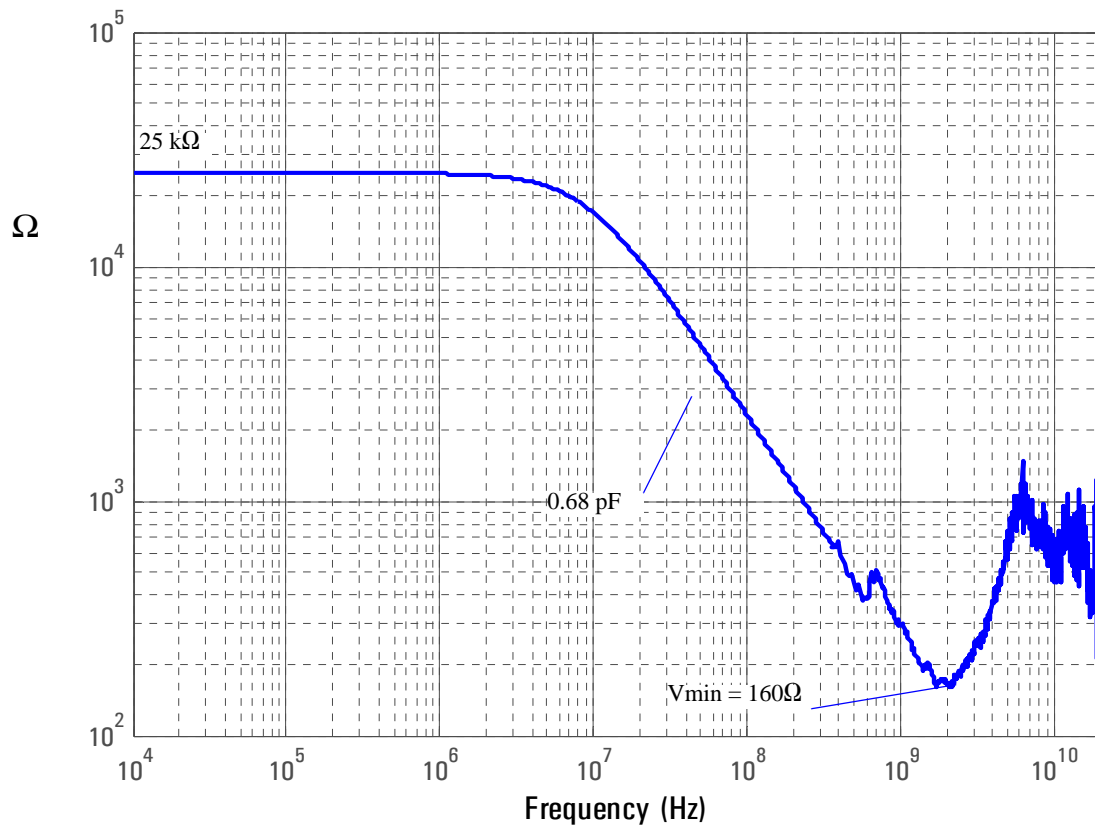

Magnitude plot of probe input impedance versus frequency (single-ended mode input).

Detailed Information for Other Configurations

This section contains graphs of the performance characteristics of the 1169A active probe using the different probe heads that come with the E2669A differential connectivity kit and the E2695A SMA probe head.

7 E2677A Solder-in Differential Probe Head (High Bandwidth)

For solder-in applications, the N5381A probe head is preferred. Variations in the manufacture and positioning of the mini-axial lead resistors used with the E2677A cause variations in the response. If you must use the E2677A, insure that the mini-axial lead resistors are positioned directly adjacent to each other and touching.

Figure 2-1

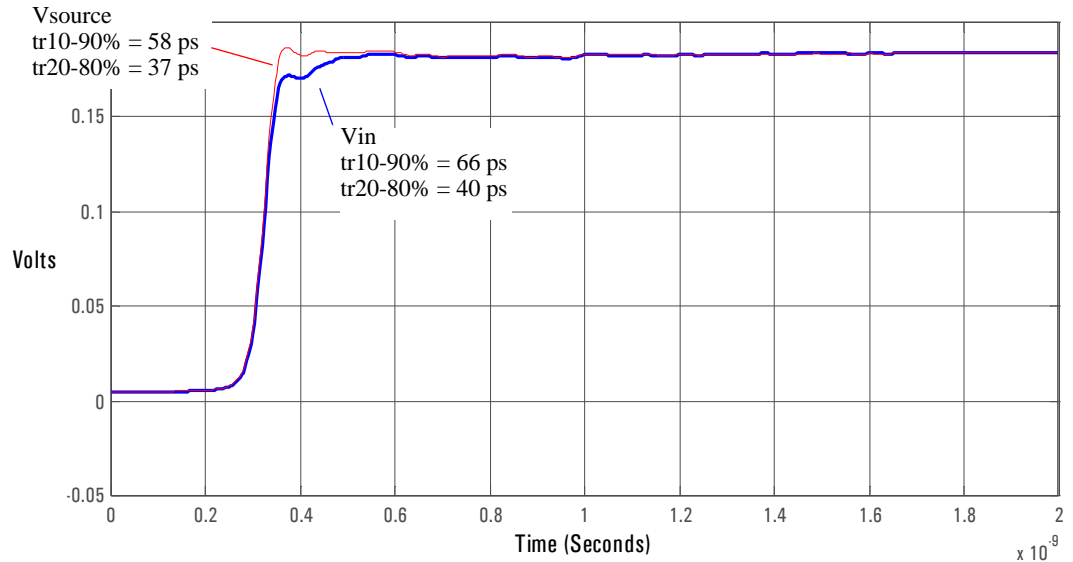

Graph of 25 Ω 58 ps step generator with and without probe connected.

Figure 2-2

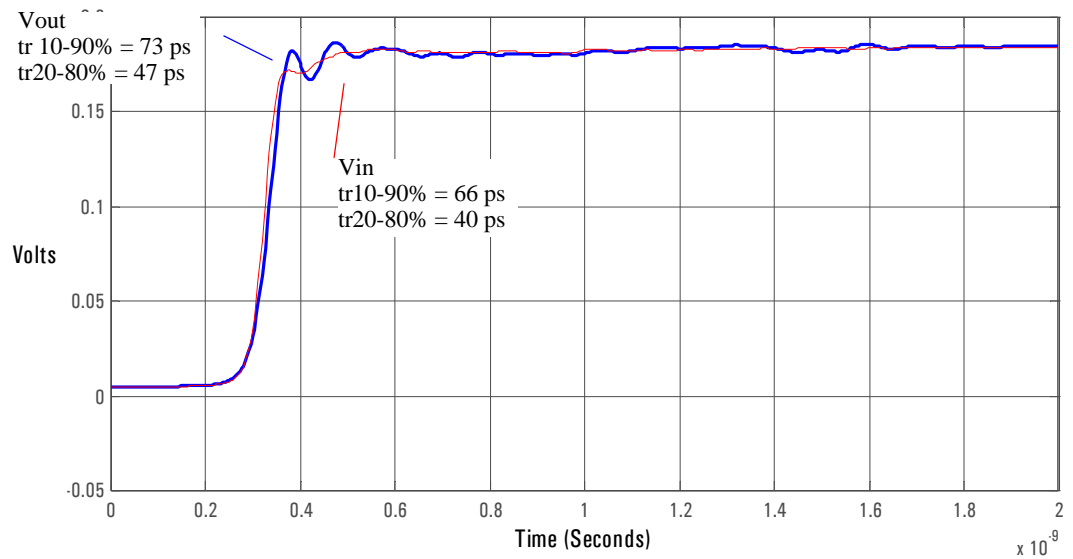

Graph of V_{in} and V_{out} of probe with a 25 Ω 58 ps step generator.

Figure 2-3

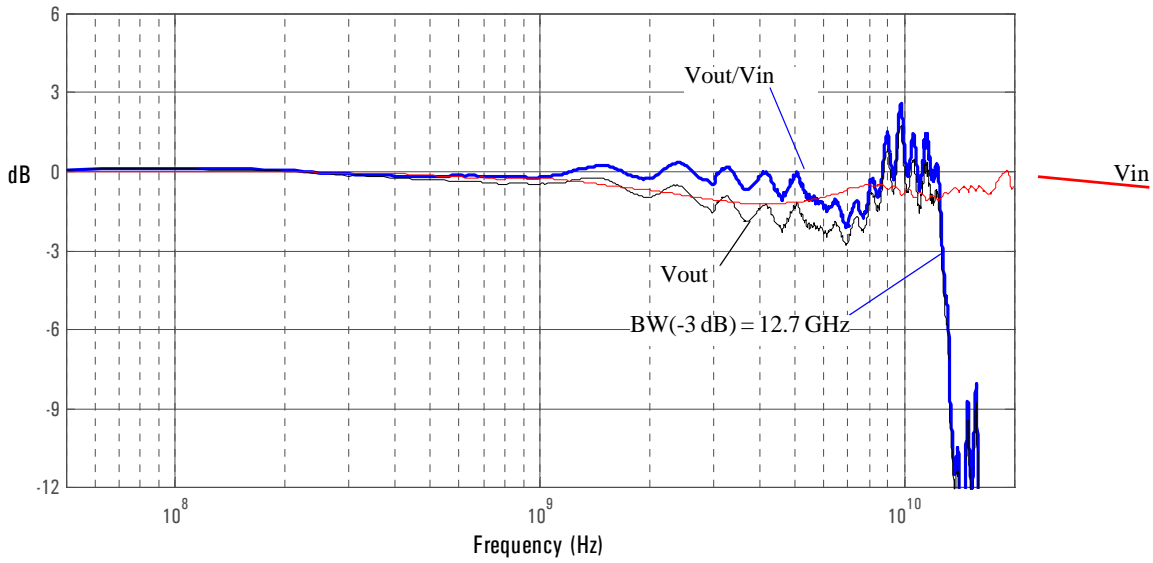

Graph of dB(V_{in}) and dB(V_{out}) + 10.8 dB of probe with a 25 Ω source and dB(V_{out}/V_{in}) + 10.8 dB frequency response.

Figure 2-4

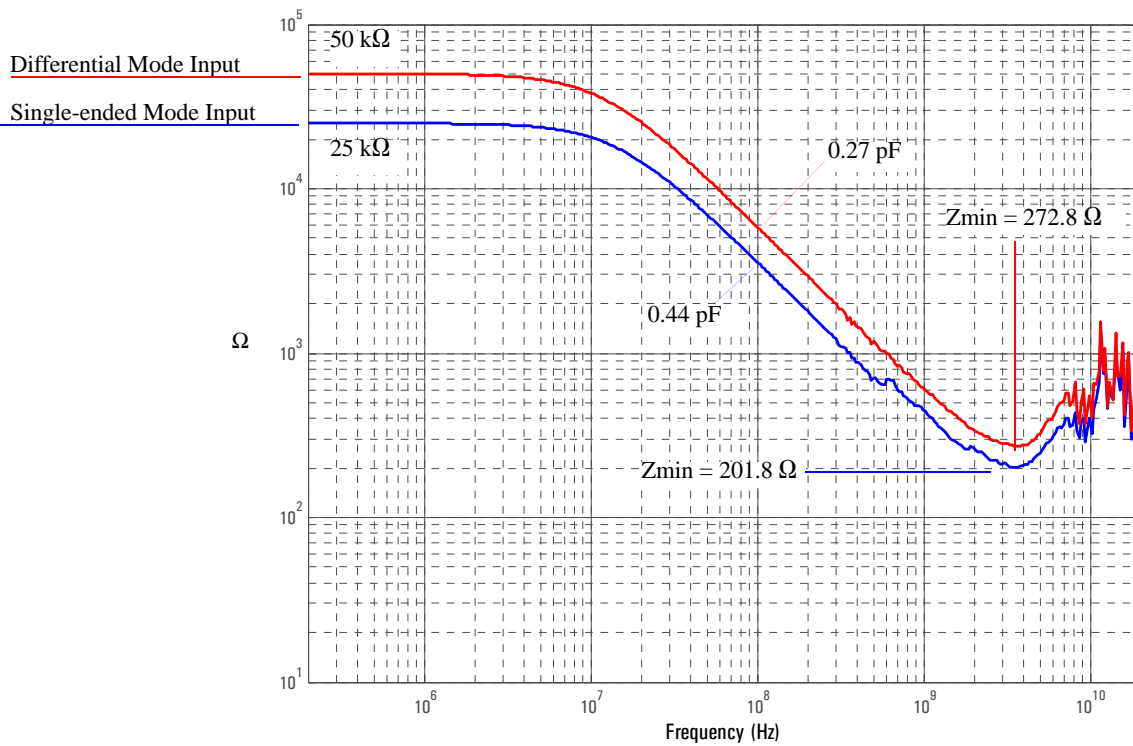

Magnitude plot of probe input impedance versus frequency.

8 E2678A Socketed Differential Probe Head (High Bandwidth)

Figure 2-5

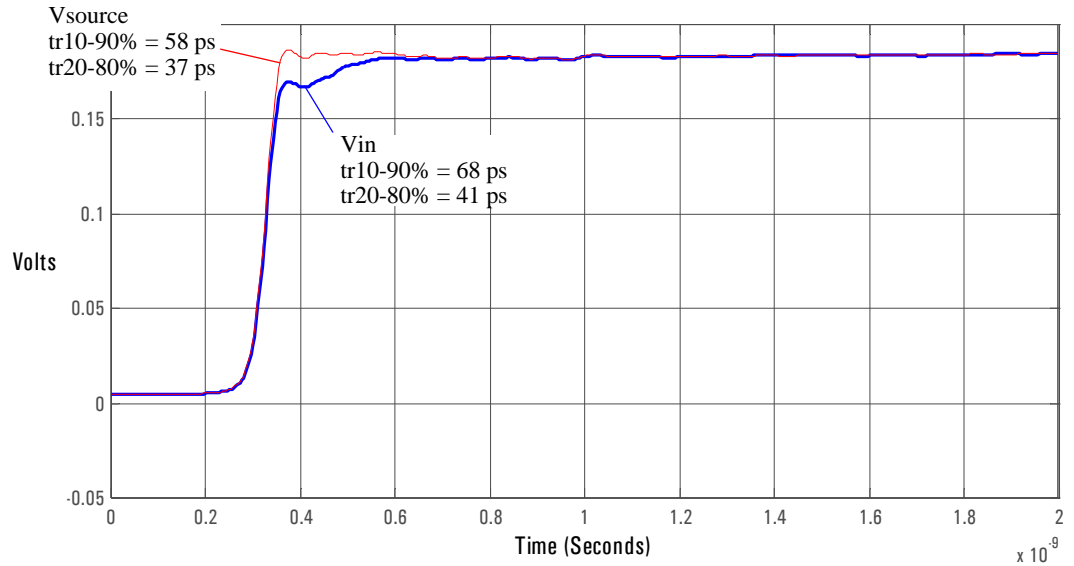

Graph of 25 Ω 58 ps step generator with and without probe connected.

Figure 2-6

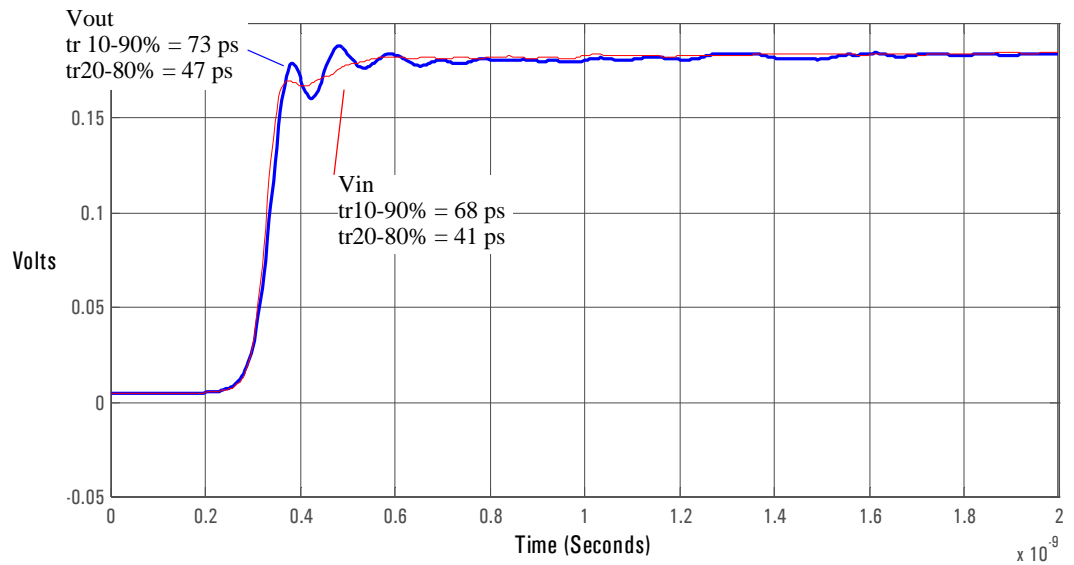

Graph of Vin and Vout of probe with a 25 Ω 58 ps step generator.

Differential and Single-ended Probe Configurations
8 E2678A Socketed Differential Probe Head (High Bandwidth)

Figure 2-7

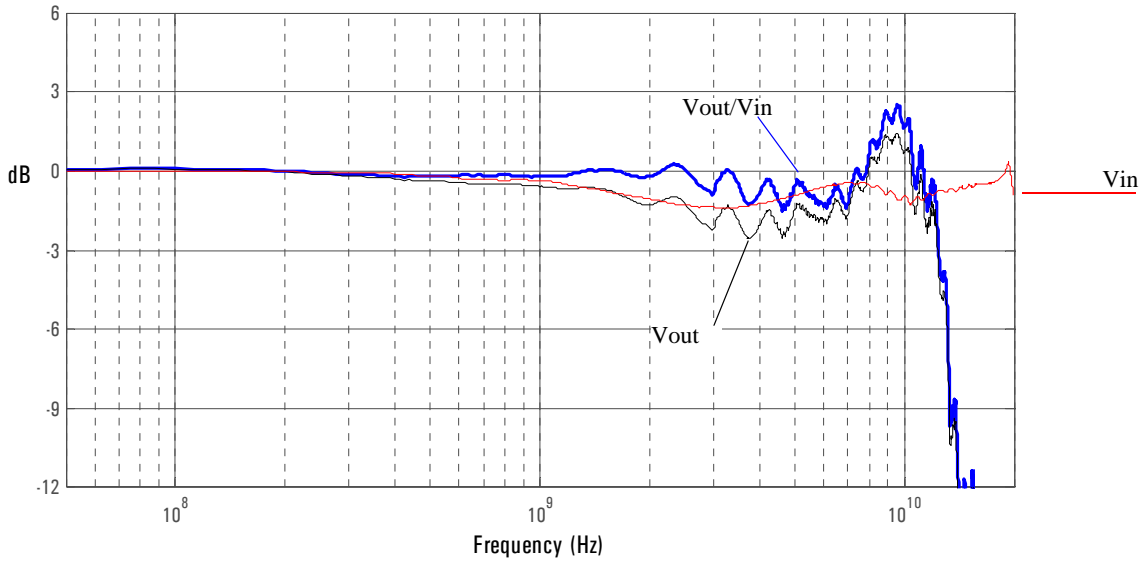

Graph of dB(V_{in}) and dB(V_{out}) + 10.8 dB of probe with a $25\ \Omega$ source and dB(V_{out}/V_{in}) + 10.8 dB frequency response.

Figure 2-8

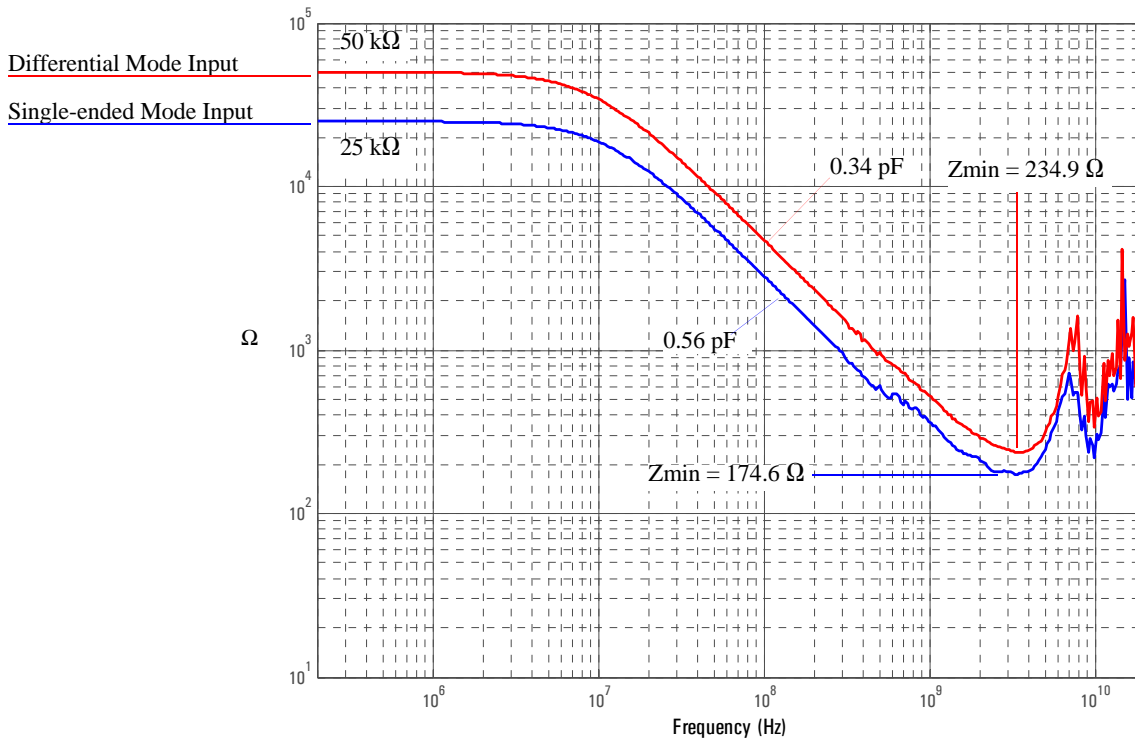

Magnitude plot of probe input impedance versus frequency.

9 E2675A Differential Browser

Figure 2-9

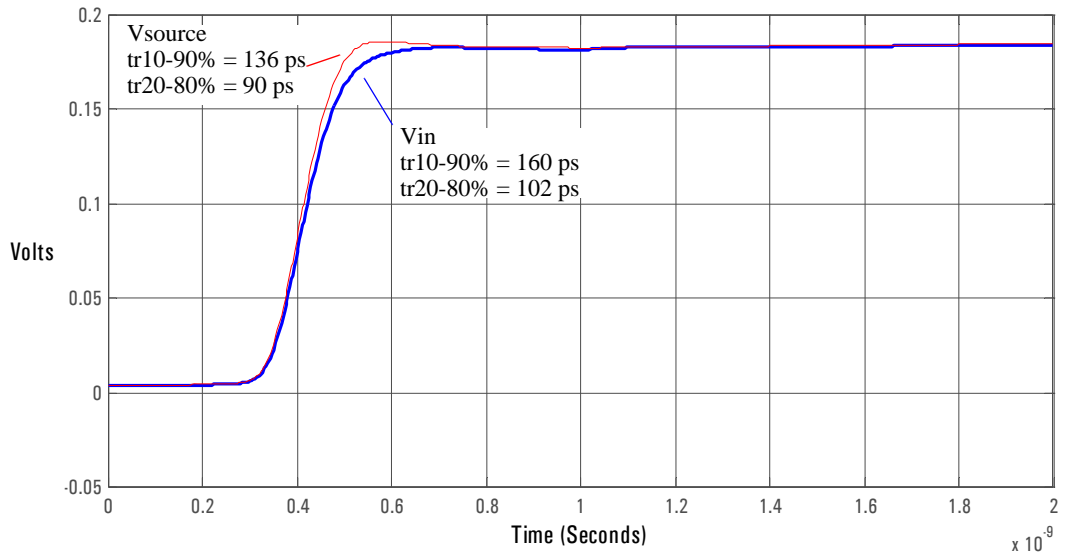

Graph of 25 Ω 136 ps step generator with and without probe connected.

Figure 2-10

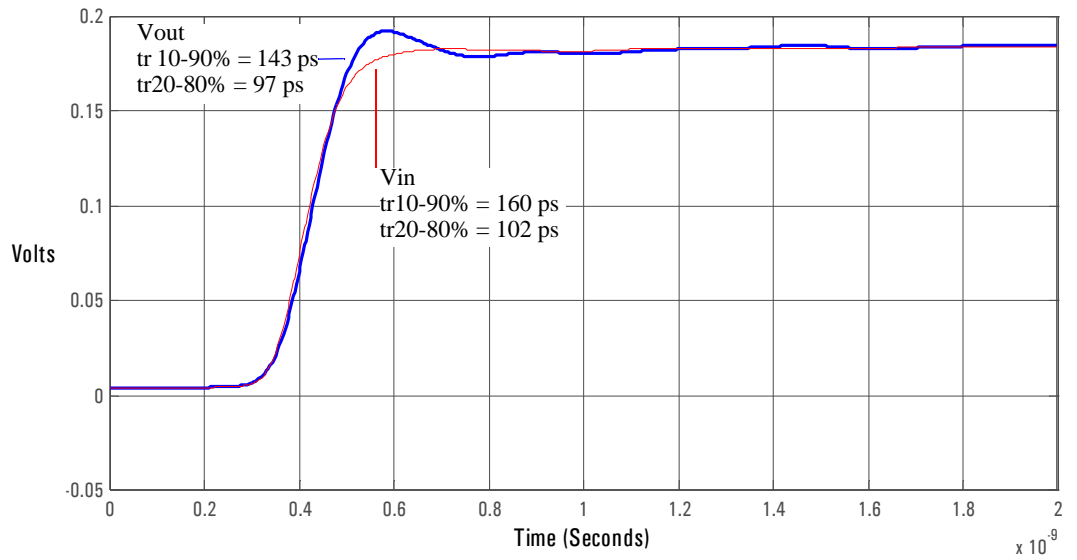

Graph of V_{in} and V_{out} of probe with a 25 Ω 136 ps step generator.

Differential and Single-ended Probe Configurations
9 E2675A Differential Browser

Figure 2-11

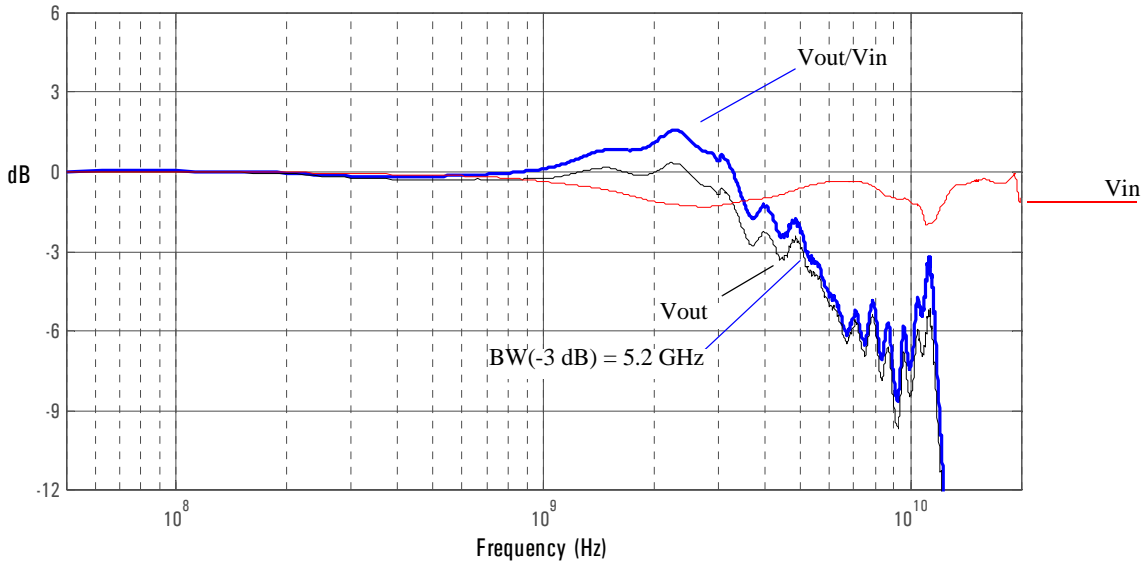

Graph of $\text{dB}(V_{in})$ and $\text{dB}(V_{out}) + 10.8\text{ dB}$ of probe with a $25\ \Omega$ source and $\text{dB}(V_{out}/V_{in}) + 10.8\text{ dB}$ frequency response.

Figure 2-12

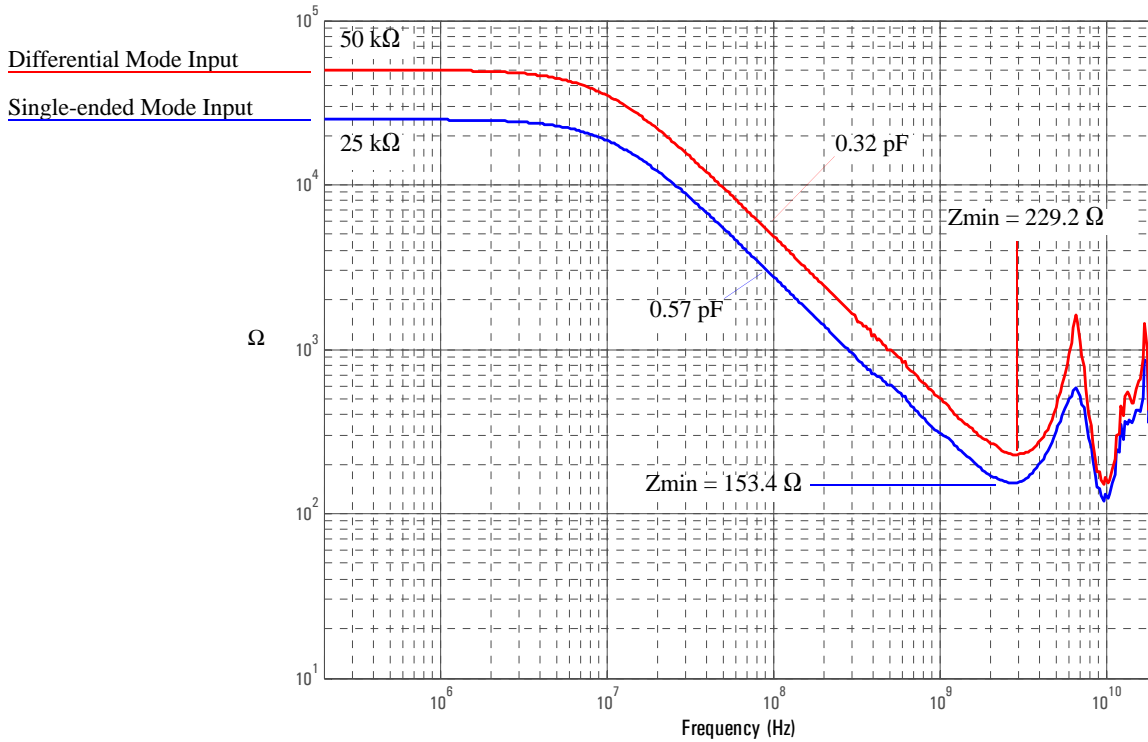

Magnitude plot of probe input impedance versus frequency.

10 E2679A Solder-in Single-ended Probe Head (High Bandwidth)

Figure 2-13

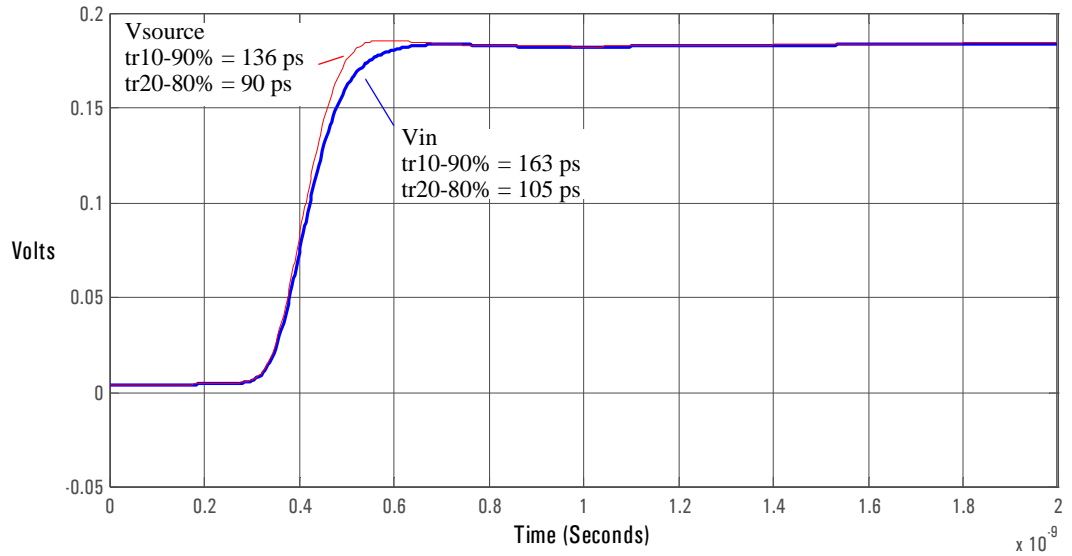

Graph of 25 Ω 136 ps step generator with and without probe connected.

Figure 2-14

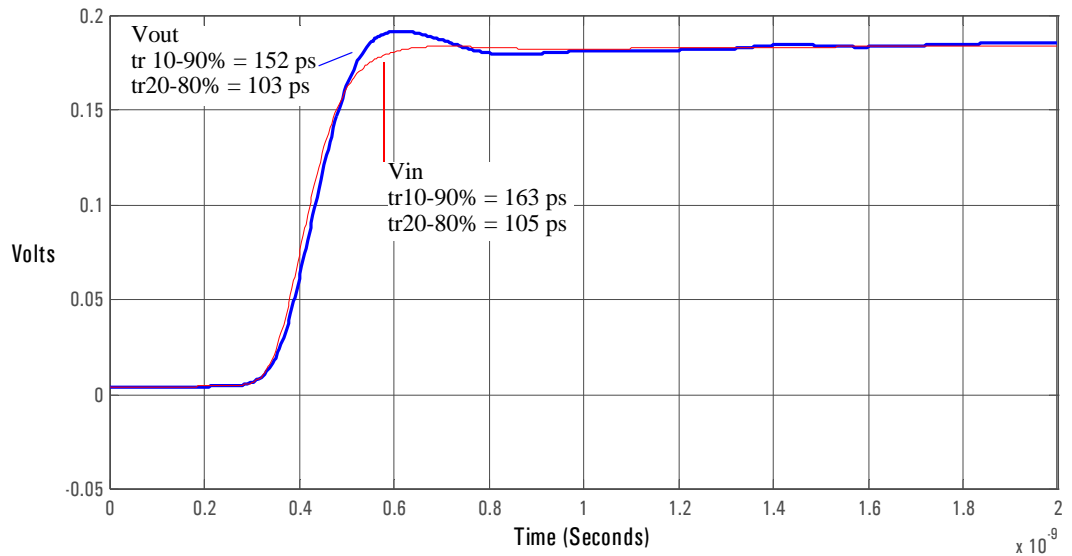

Graph of V_{in} and V_{out} of probe with a 25 Ω 136 ps step generator.

Differential and Single-ended Probe Configurations
10 E2679A Solder-in Single-ended Probe Head (High Bandwidth)

Figure 2-15

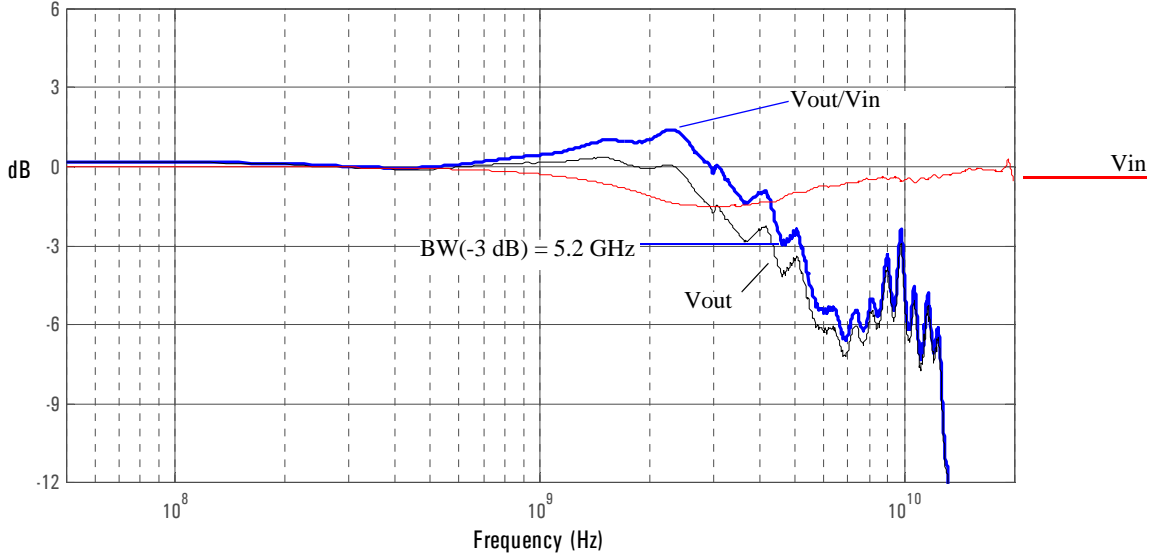

Graph of $\text{dB}(V_{in})$ and $\text{dB}(V_{out}) + 10.8\text{ dB}$ of probe with a $25\ \Omega$ source and $\text{dB}(V_{out}/V_{in}) + 10.8\text{ dB}$ frequency response.

Figure 2-16

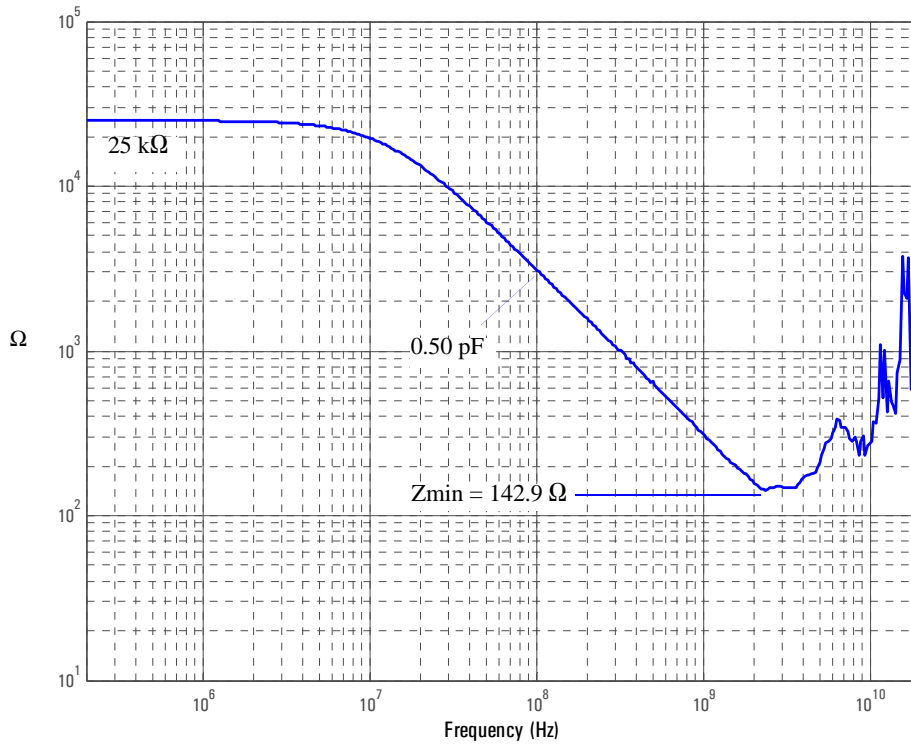

Magnitude plot of probe input impedance versus frequency.

11 E2676A Single-ended Browser

Figure 2-17

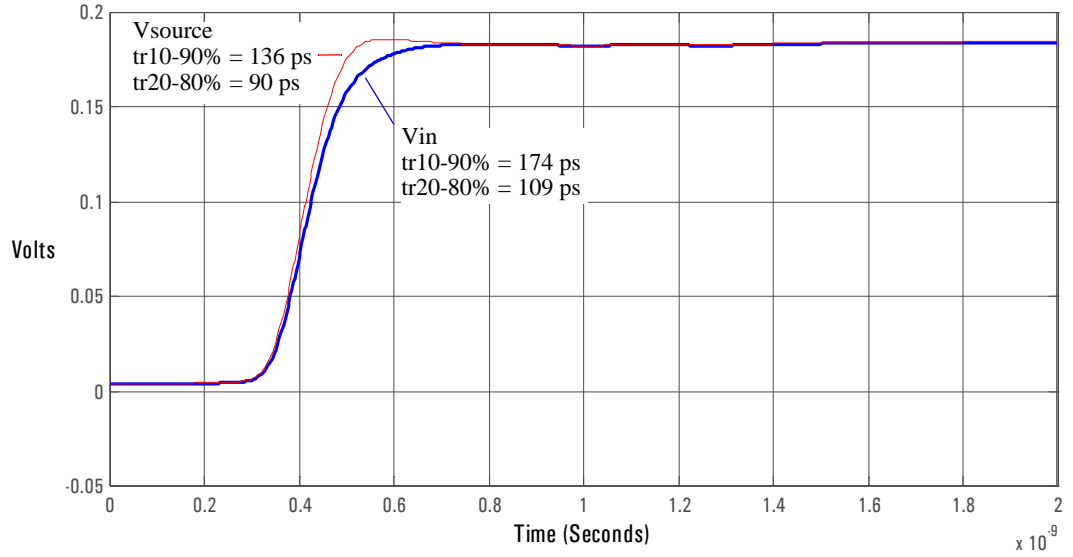

Graph of 25 Ω 100 ps step generator with and without probe connected.

Figure 2-18

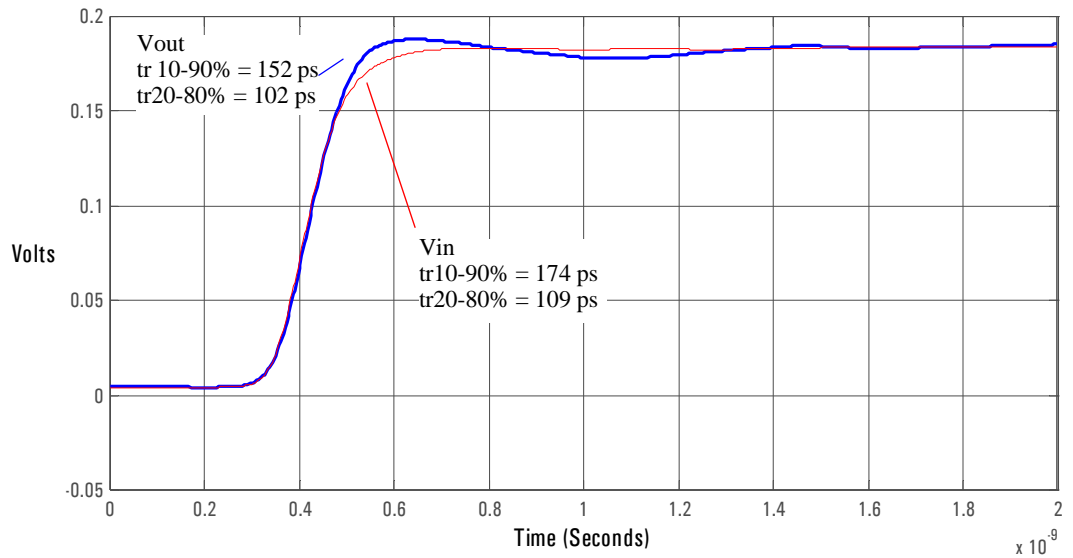

Graph of V_{in} and V_{out} of probe with a 25 Ω 100 ps step generator.

Differential and Single-ended Probe Configurations
11 E2676A Single-ended Browser

Figure 2-19

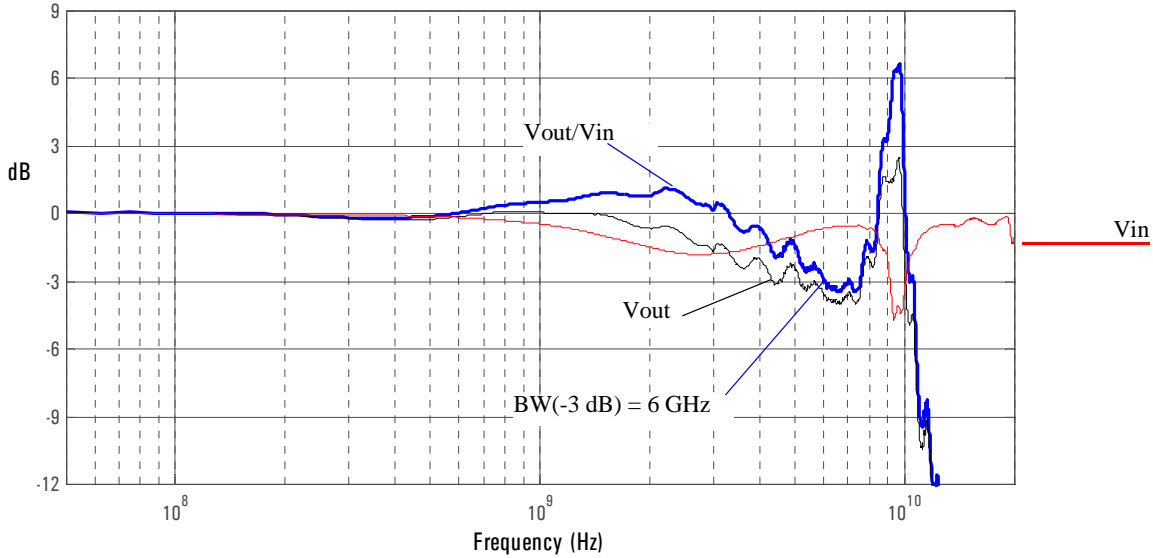

Graph of $\text{dB}(V_{in})$ and $\text{dB}(V_{out}) + 10.8\text{ dB}$ of probe with a $25\ \Omega$ source and $\text{dB}(V_{out}/V_{in}) + 10.8\text{ dB}$ frequency response.

The ground inductance and structure of the E2676A Single-ended Browser causes a resonant peak at $\sim 10\text{ GHz}$. This probe head was designed for the 1134A 7 GHz probe system. The input signal should be limited to an equivalent bandwidth of about 4.2 GHz (110 ps, 10-90%) to prevent ringing at 10 GHz

Figure 2-20

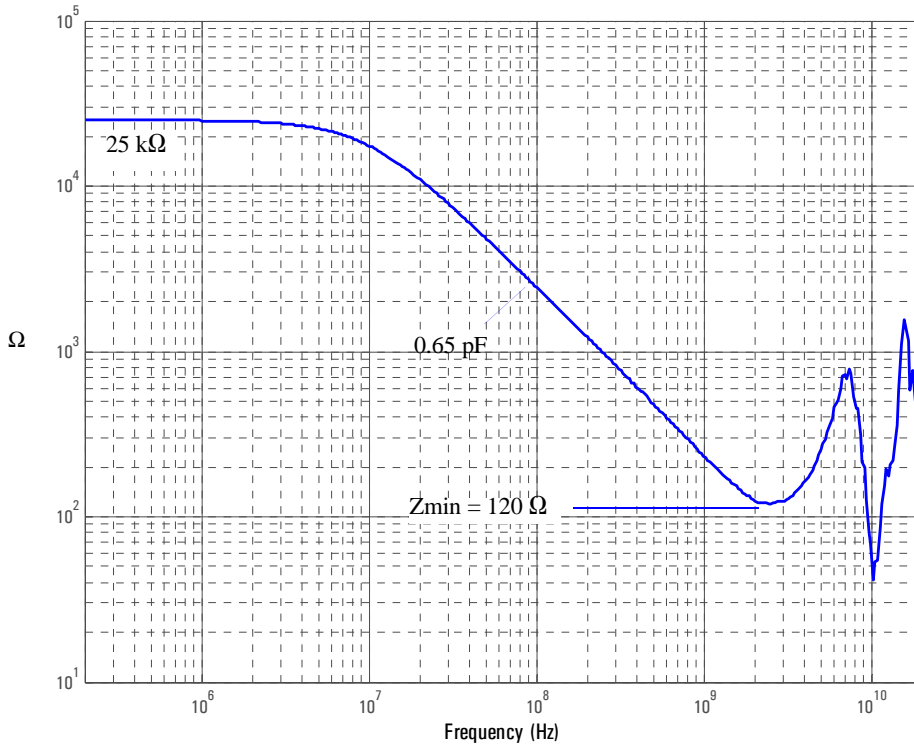

Magnitude plot of probe input impedance versus frequency.

12 E2678A Socketed Differential Probe Head with Damped Wire Accessory

Due to reflections on the long wire accessories, signals being probed should be limited to ~ 240 ps rise time measured at the 10% and 90% amplitude levels. This is equivalent to ~ 1.5 GHz bandwidth.

Figure 2-21

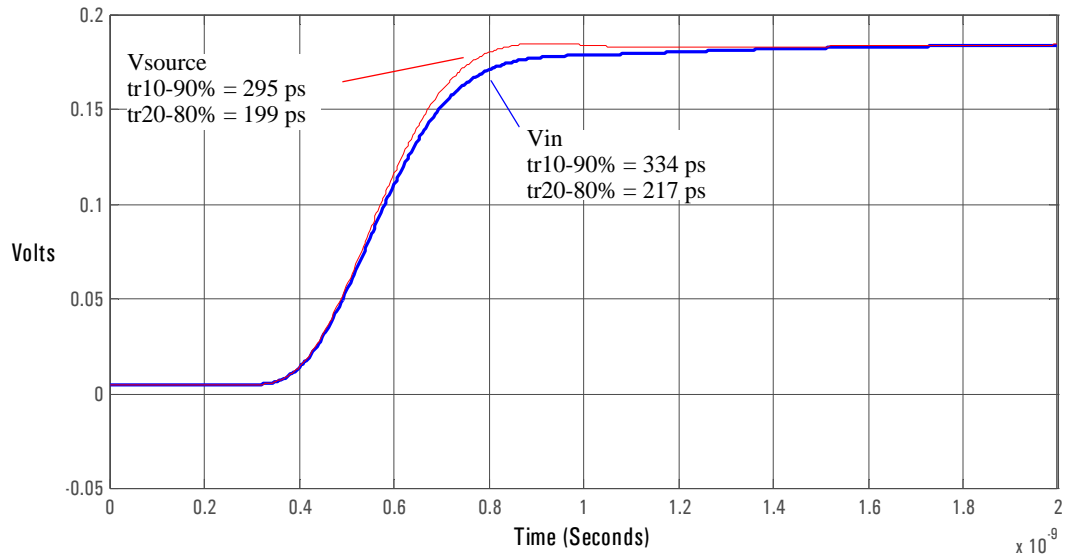

Graph of 25 Ω 295 ps step generator with and without probe connected.

Figure 2-22

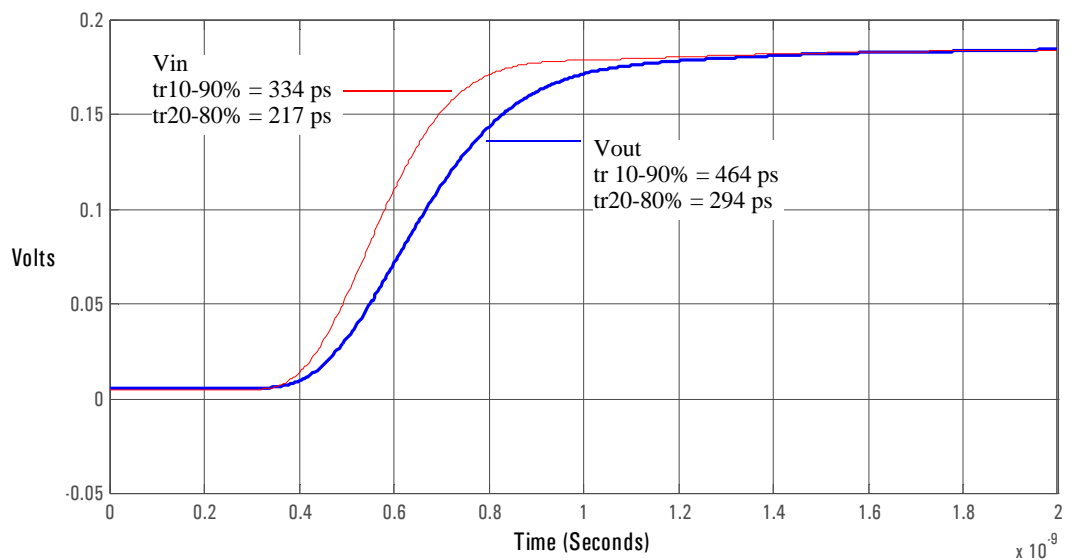

Graph of V_{in} and V_{out} of probe with a 25 Ω 295 ps step generator.

Differential and Single-ended Probe Configurations
12 E2678A Socketed Differential Probe Head with Damped Wire Accessory

Figure 2-23

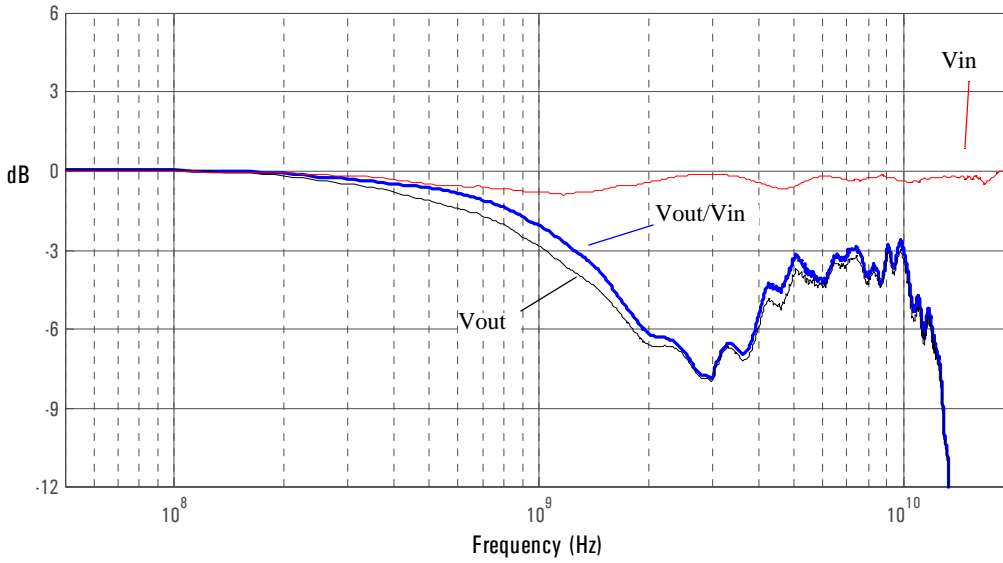

Graph of $\text{dB}(V_{in})$ and $\text{dB}(V_{out}) + 10.8 \text{ dB}$ of probe with a 25Ω source and $\text{dB}(V_{out}/V_{in}) + 10.8 \text{ dB}$ frequency response.

Figure 2-24

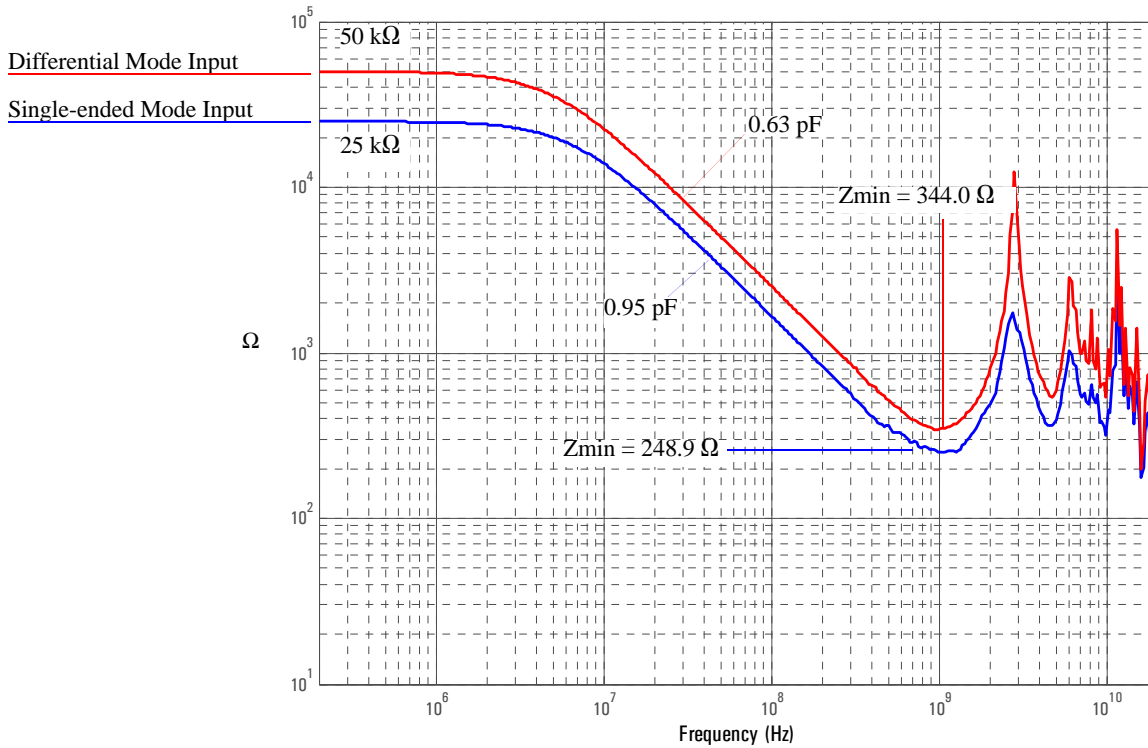

Magnitude plot of probe input impedance versus frequency.

13 E2695A SMA Probe Head

Figure 2-25

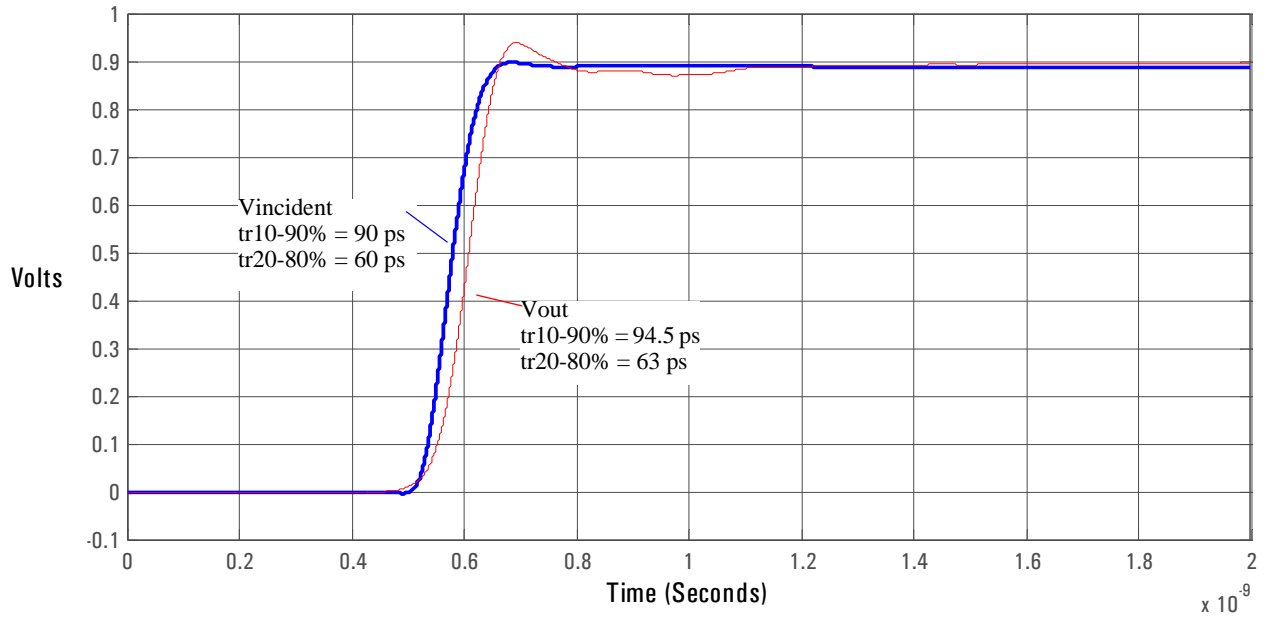

Graph of Vincident and Vout of probe with a 90 ps step.

Figure 2-26

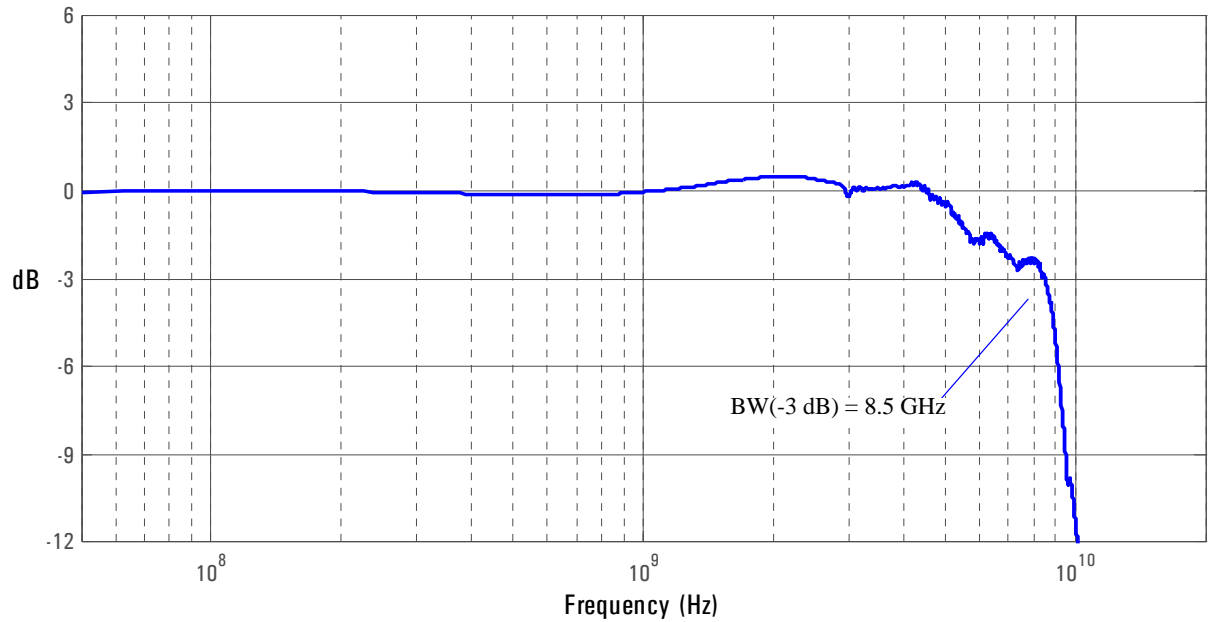

Magnitude response of differential insertion loss +1.03 dB.

N5380A SMA Probe Head with the 1134A InfiniiMax Probe

Figure 2-27

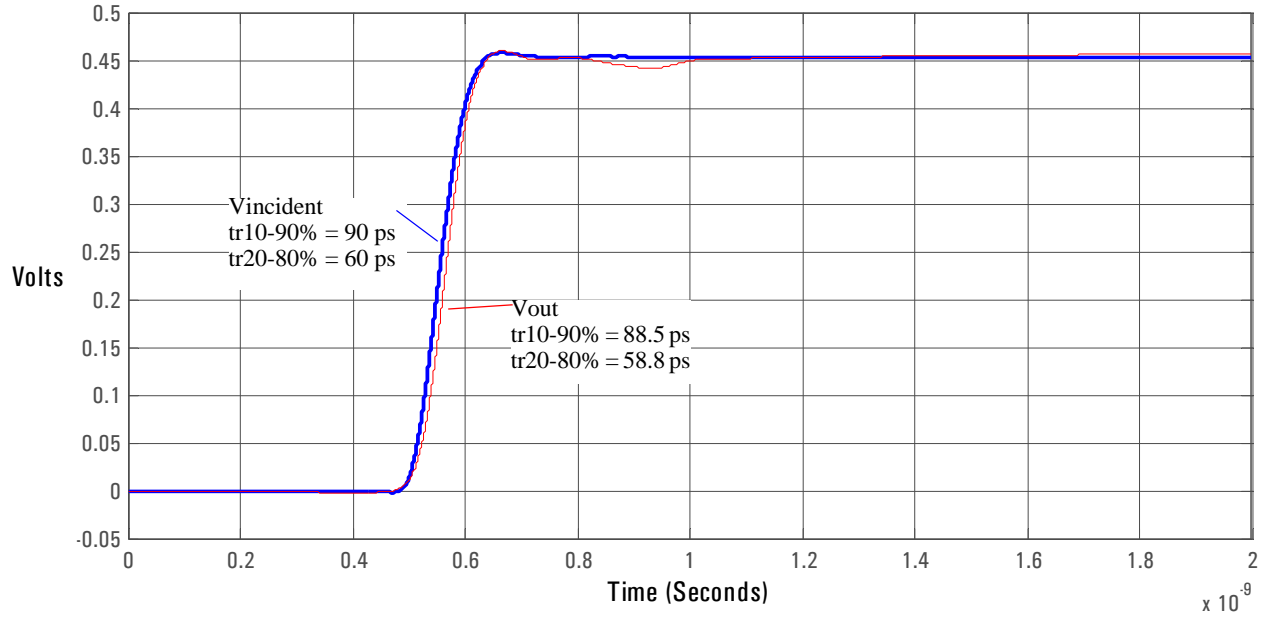

Graph of Vincident and Vout of probe with a 90 ps step.

Figure 2-28

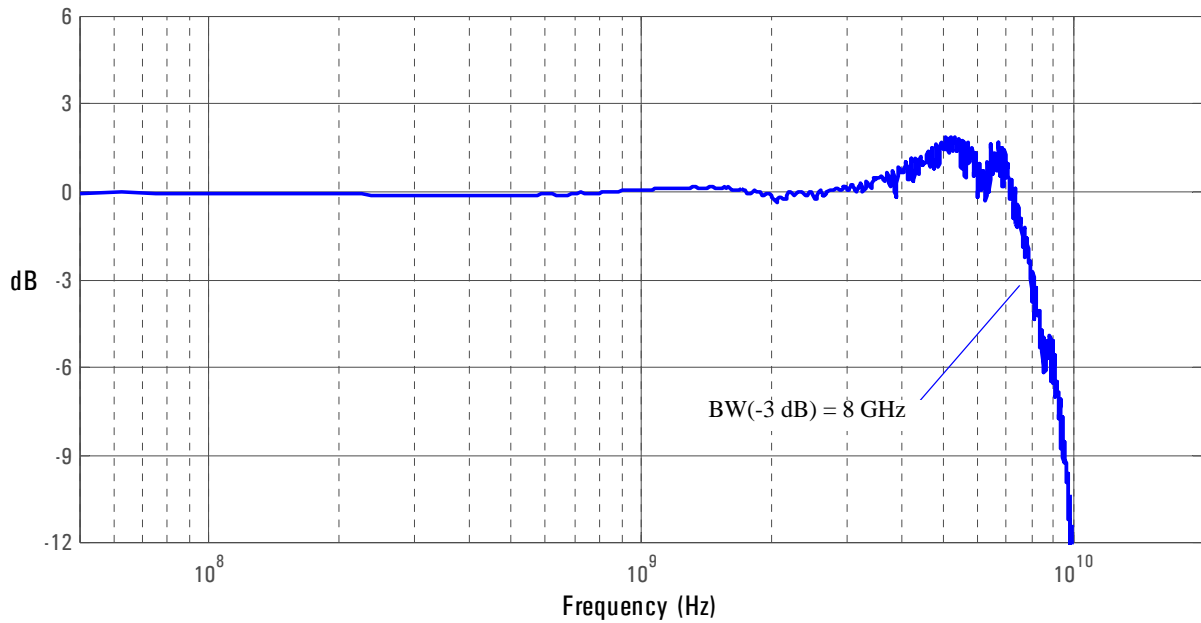

Magnitude response of differential insertion loss +16.03 dB.

N5381A Solder-in Differential Probe Head with 2 x Longer Wires

The following graph shows the probe response to a 25 Ω , 58 ps step generator with the recommended wire length, twice the recommended wire length with wires parallel to each other, and twice the recommended wire length with wires spread 90 degrees.

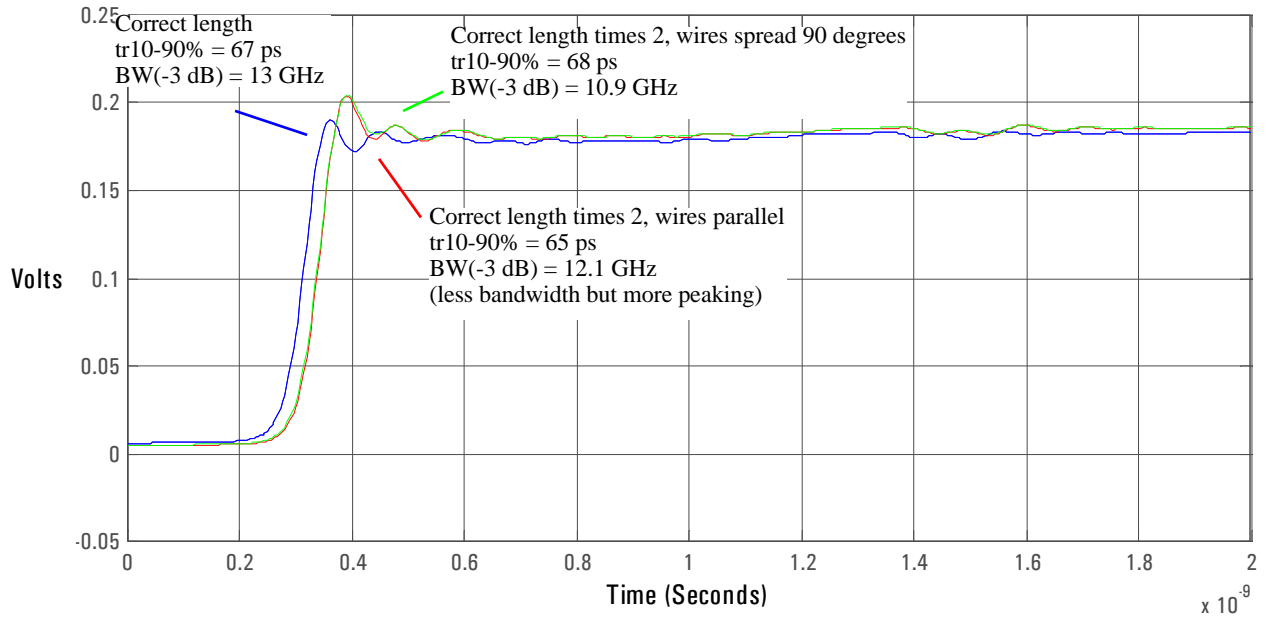

N2887A/N2888A Soft Touch Probe Heads

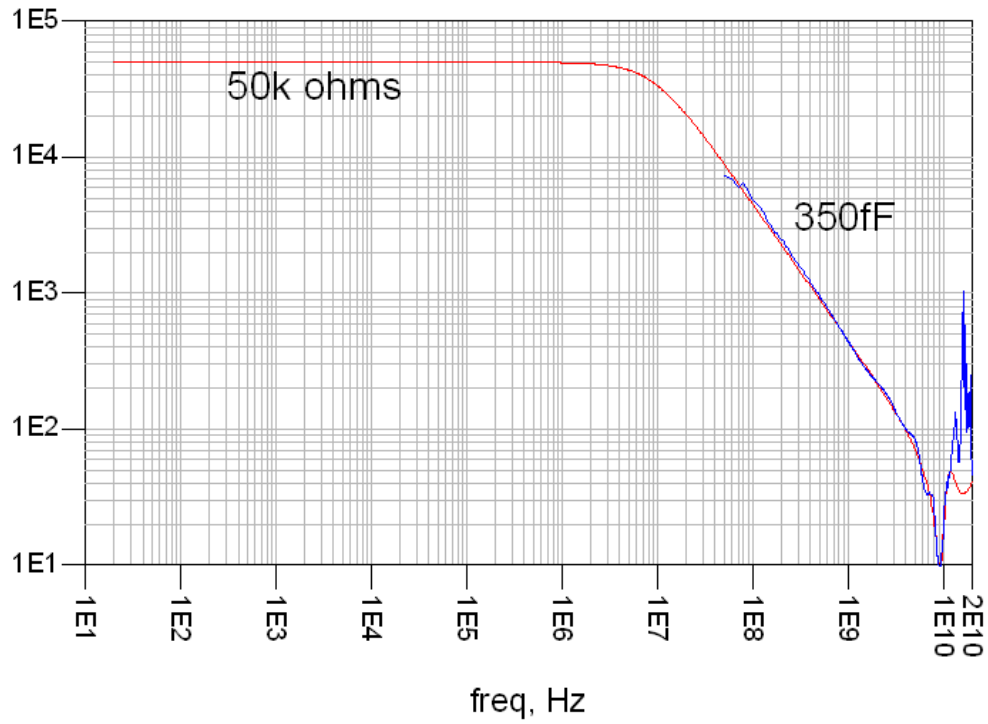

Differential input impedance (red = model, blue = measured)

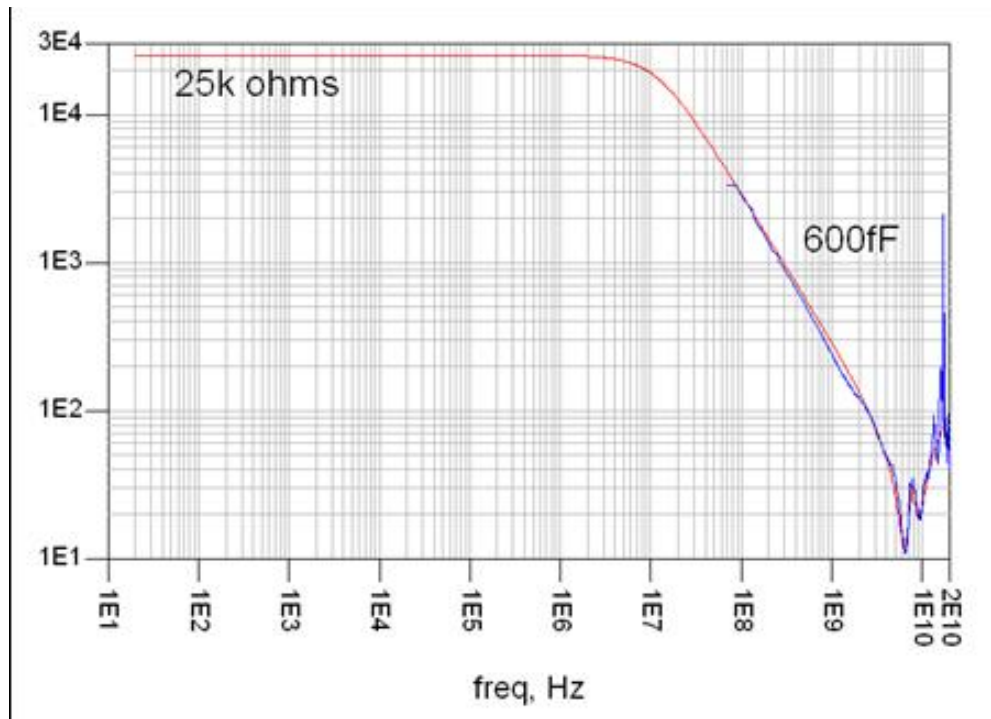

Single-ended input impedance (red = model, blue = measured)

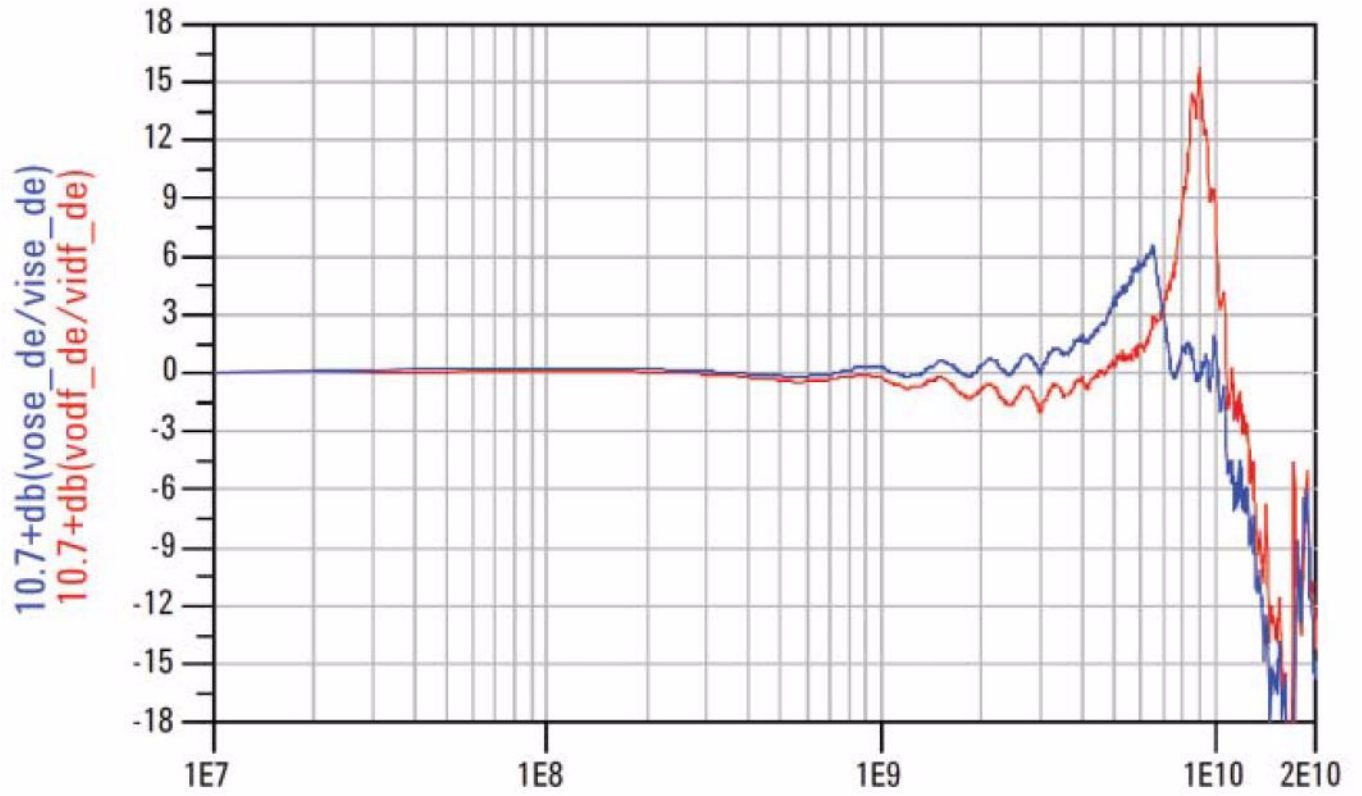

Frequency response, N2887A with an 1169A 12 GHz amplifier (red = differential, blue = single-ended)

**Differential and Single-ended Probe Configurations
N2887A/N2888A Soft Touch Probe Heads**

Input Impedance SPICE Models for N5425A, N5426A, N5381A, N5382A, and N2887A/N2888A Probe Heads

This document contains SPICE models that can be used to predict the probe loading effects of the InfiniiMax II active probes. Important points about these SPICE models are:

- SPICE models shown here are only for input impedance which allows modeling of the probe loading effects. Probe transfer function is generally flat to the specified bandwidth.
- These input impedance is a function of the probe head type only. The probe amp bandwidth (10 GHz 1168A or 12 GHz 1169A) does not have any effect on the input impedance of the probe heads.

An input impedance plot is given that shows the matching of the measured data to the modeled data. Matching is generally very good up to the specified bandwidth of the probe head.

Input Impedance SPICE Model for N5381A and N5382A Probe Heads

*SPICE Model for InfiniiMax 1160 Series
 *N5381A (&N5382A) Differential Probe Heads

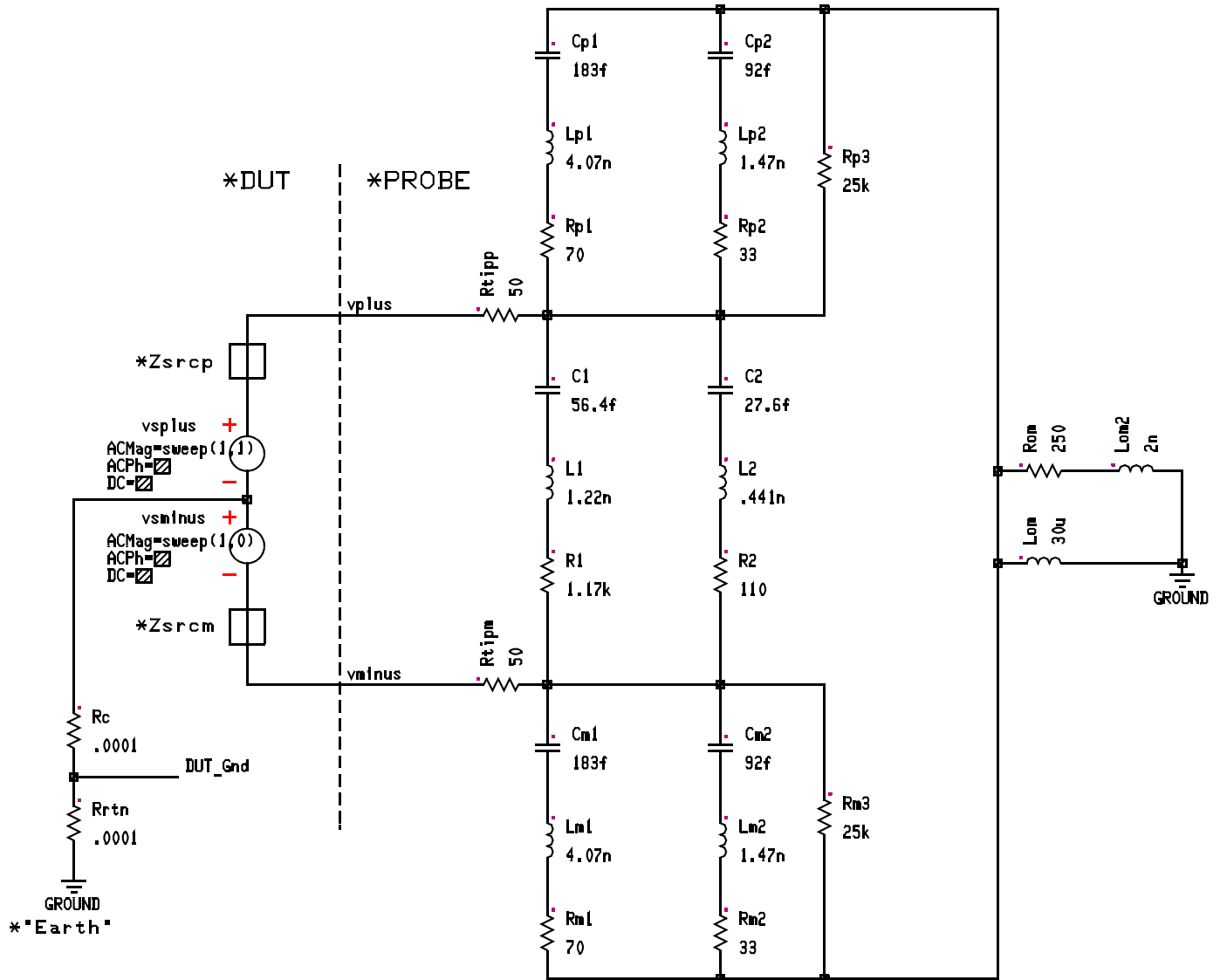

Spice Models

Input Impedance SPICE Model for N5381A and N5382A Probe Heads

- Rrtn (or Zrtn) is dependent on connection from DUT ground to "Earth" ground. Most likely modeled by a parallel RL similar to Rom || Lom. Will have slight effect on single-ended input Z and no effect on differential input Z.

When using differential probe to probe single-ended signals:

- vplus connected to DUT signal
- vminus connected to DUT ground which means that $R_c = 0$, $v_{\text{minus}} = 0$, and $Z_{\text{srcm}} = 0$.
- Input impedance is defined to be $v_{\text{plus}}/i(v_{\text{plus}})$

When using differential probe to probe differential signals:

- R_c (or Z_c) will depend on the DUT circuit.
- vplus connected to DUT plus signal
- vminus connected to DUT minus signal.
- Input impedance is defined to be $(v_{\text{plus}} - v_{\text{minus}})/i(v_{\text{plus}})$

SPICE Deck

```
C2 %44 %40 27.6f
Cm2 %41 %38 92f
Cp2 %43 %36 92f
Cp1 %43 %34 183f
Cm1 %41 %31 183f
C1 %44 %28 56.4f
vsminus %16 %vminus ACMag=sweep(1,0)
vsplus %vplus %16 ACMag=sweep(1,1)
Lom2 %47 %0 2n
Lom %43 %0 30u
L2 %40 %39 .441n
Lm2 %38 %37 1.47n
Lp2 %36 %35 1.47n
Lp1 %34 %33 4.07n
Lm1 %31 %30 4.07n
L1 %28 %32 1.22n
Rm3 %41 %43 25k
Rp3 %43 %44 25k
Rom %43 %47 250
R2 %39 %41 110
Rm2 %37 %43 33
Rp2 %35 %44 33
Rp1 %33 %44 70
Rm1 %30 %43 70
R1 %32 %41 1.17k
Rtipm %vminus %41 50
Rtipp %vplus %44 50
Rrtn %15 %0 .0001
Rc %16 %15 .0001
```

.END

Measured and Modeled Data Matching

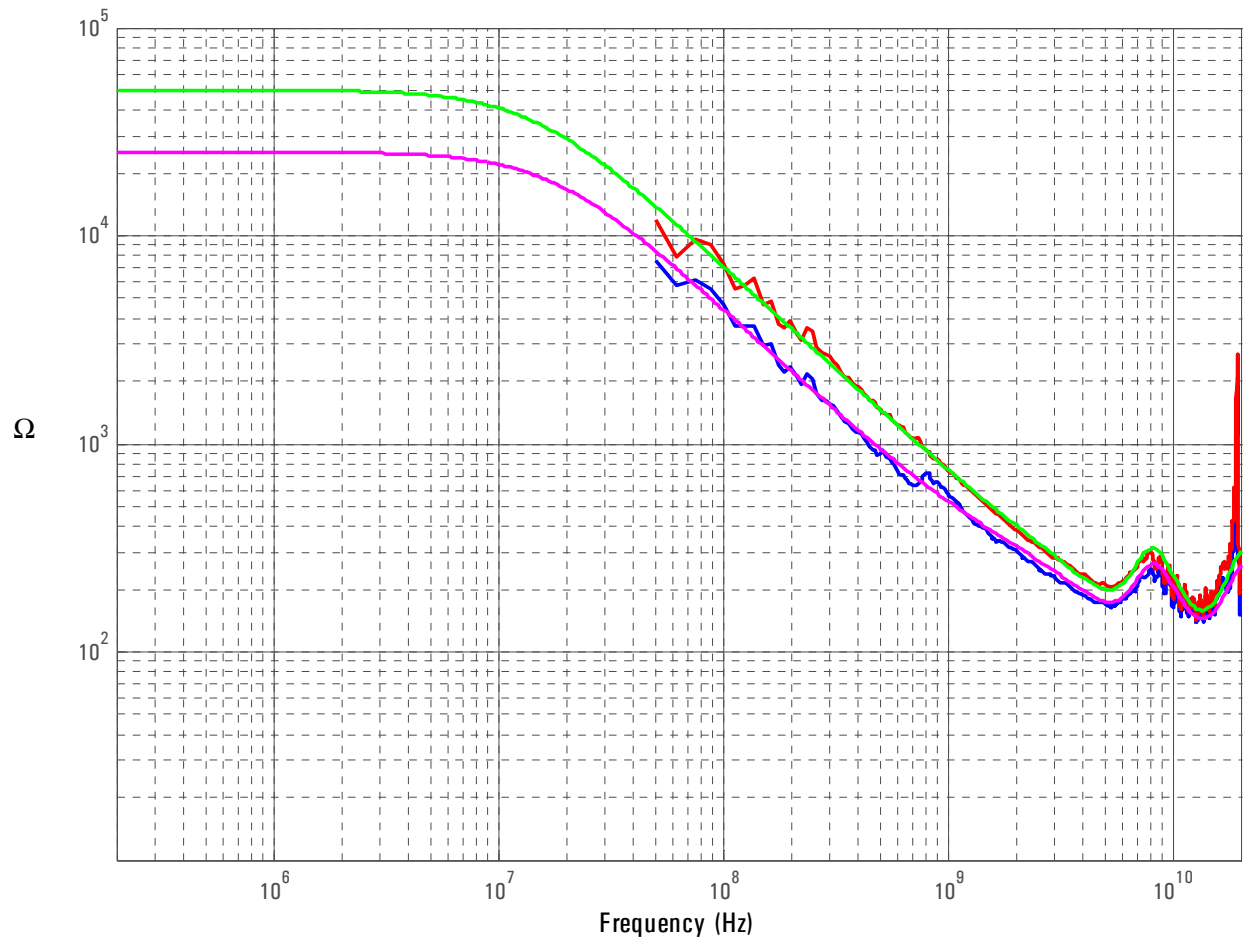

Input Impedance SPICE Model for N5425A ZIF Probe Head with N5426A ZIF Tip Attached

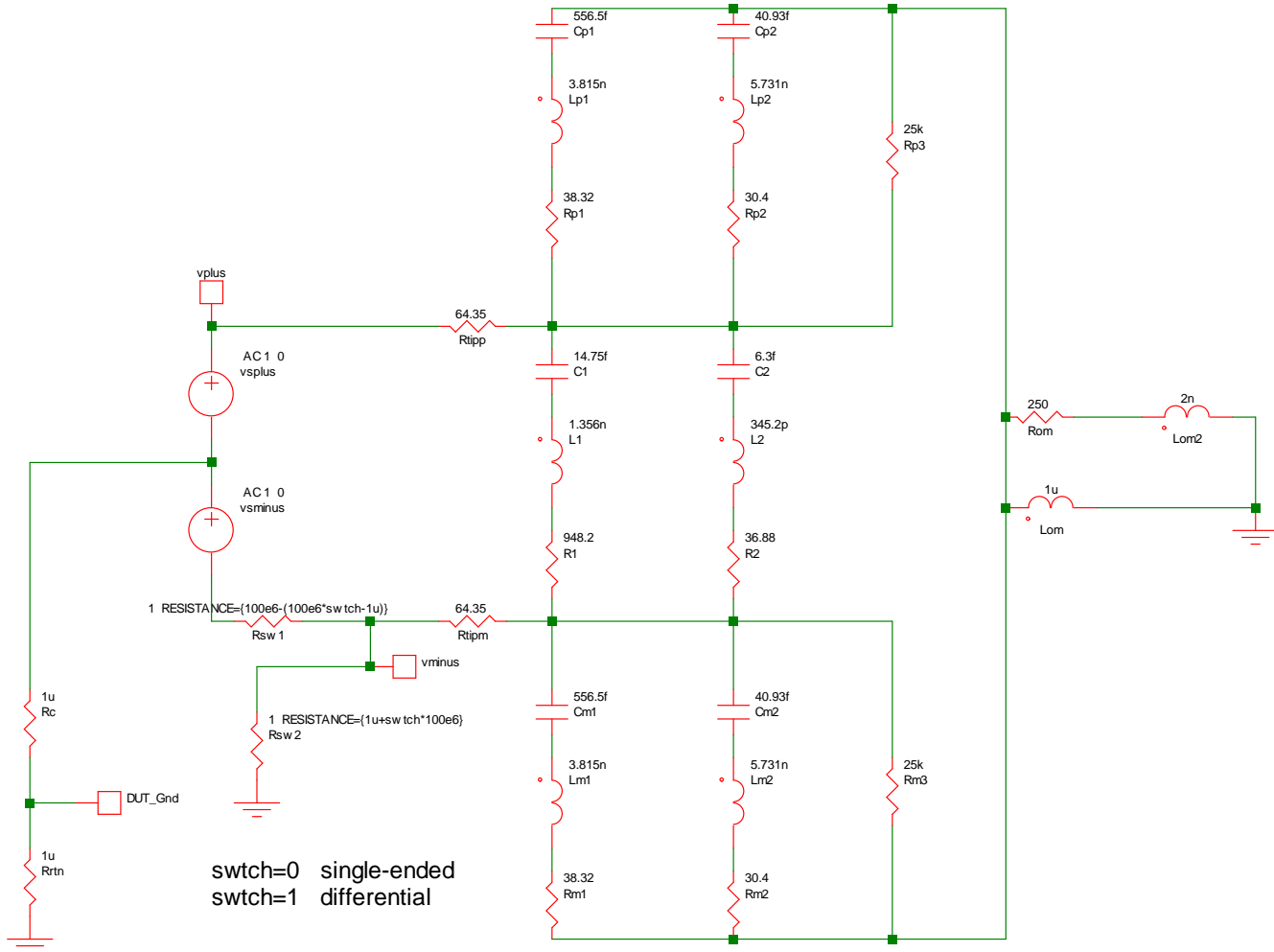

When using differential probe to probe single-ended signals:

- vplus connected to DUT signal
- vminus connected to DUT ground which means that $R_{sw1} = \infty$ and $R_{sw2} = 0$
- Input impedance is defined to be $v_{plus}/i(v_{plus})$

When using differential probe to probe differential signals:

- R_c (or Z_c) will depend on the DUT circuit.
- vplus connected to DUT plus signal
- vminus connected to DUT minus signal.
- Input impedance is defined to be $(v_{plus} - v_{minus})/i(v_{plus})$

Input Impedance SPICE Model for N5425A ZIF Probe Head with N5426A ZIF Tip Attached**SPICE Deck of N5425A with N5426A ZIF Tip Attached**

```

Lom2 Rom_P 0 2n
Lm2 Cm2_N Lm2_N 5.731n
Rtipp Rp3_N vplus 64.35
Lm1 Cm1_N Lm1_N 3.815n
Rom Rom_P Cp1_P 250
Cp1 Cp1_P Cp1_N 556.5f
Cp2 Cp1_P Cp2_N 40.93f
Lp1 Cp1_N Lp1_N 3.815n
Lp2 Cp2_N Lp2_N 5.731n
Cm2 R1_N Cm2_N 40.93f
vsminus vsplus_N vsminus_N AC 1 0
L1 C1_N L1_N 1.356n
L2 C2_N L2_N 345.2p
Rp1 Lp1_N Rp3_N 38.32
Cm1 R1_N Cm1_N 556.5f
Rp2 Lp2_N Rp3_N 30.4
Rp3 Cp1_P Rp3_N 25k
Rrtn DUT_Gnd 0 1u
Rsw2 vminus 0 1 1u+swtch*100e6
vsplus vplus vsplus_N AC 1 0
Rm2 Lm2_N Cp1_P 30.4
Rm3 R1_N Cp1_P 25k
Rsw1 vminus vsminus_N 100e6-(100e6*swtch-1u)
Lom Cp1_P 0 1u
C2 Rp3_N C2_N 6.3f
Rm1 Lm1_N Cp1_P 38.32
Rc vsplus_N DUT_Gnd 1u
C1 Rp3_N C1_N 14.75f
Rtipm R1_N vminus 64.35
R1 L1_N R1_N 948.2
R2 L2_N R1_N 36.88

.AC DEC 200 200k 20G SWEEP PARAM=swtch LIN 2 0 1

.PARAM swtch=1

```

Spice Models
Input Impedance SPICE Model for N5425A ZIF Probe Head with N5426A ZIF Tip Attached

Measured and Modeled Data Matching

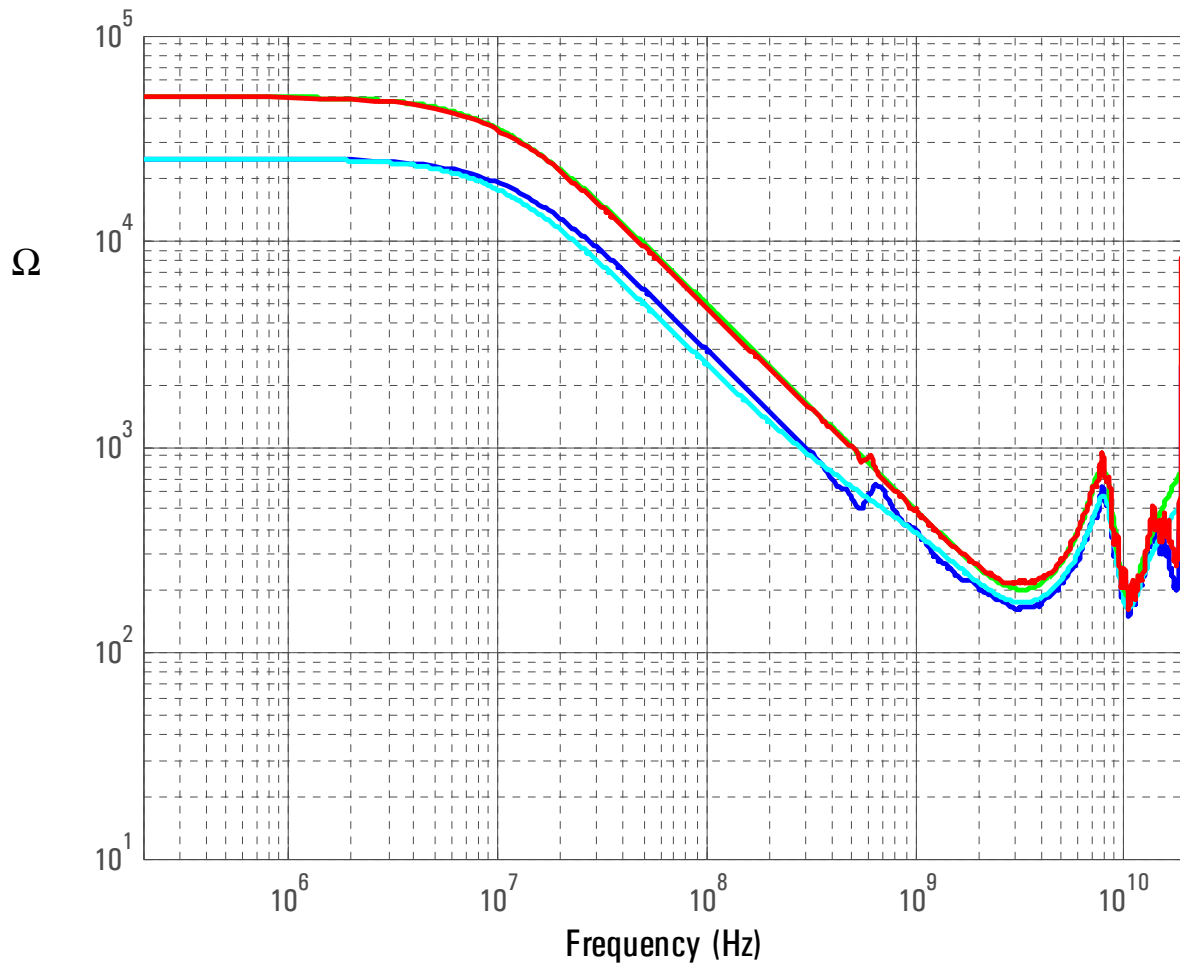

Input Impedance SPICE Model for N5426A ZIF Tip

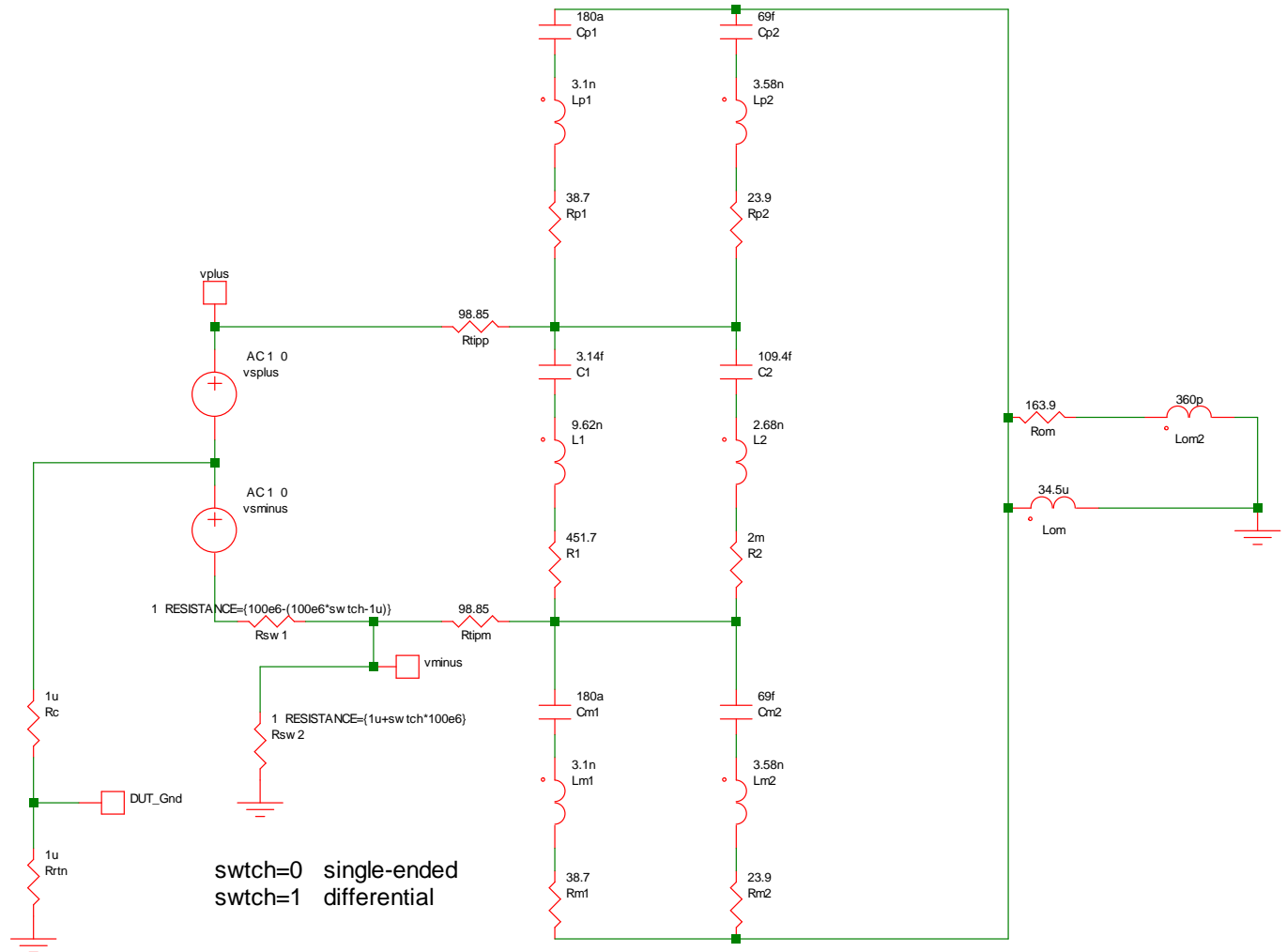

Spice Models
Input Impedance SPICE Model for N5426A ZIF Tip

SPICE Deck of N5426A

```
Lom2 Rom_P 0 360p
Lm2 Cm2_N Lm2_N 3.58n
Rtipp Rp3_N vplus 98.85
Lm1 Cm1_N Lm1_N 3.1n
Rom Rom_P Cp1_P 163.9
Cp1 Cp1_P Cp1_N 180a
Cp2 Cp1_P Cp2_N 69f
Lp1 Cp1_N Lp1_N 3.1n
Lp2 Cp2_N Lp2_N 3.58n
Cm2 R1_N Cm2_N 69f
vsminus vsplus_N vsminus_N AC 1 0
L1 C1_N L1_N 9.62n
L2 C2_N L2_N 2.68n
Rp1 Lp1_N Rp3_N 38.7
Cm1 R1_N Cm1_N 180a
Rp2 Lp2_N Rp3_N 23.9
Rrtn DUT_Gnd 0 1u
Rsw2 vminus 0 1 RESISTANCE={1u+swtch*100e6}
vsplus vplus vsplus_N AC 1 0
Rm2 Lm2_N Cp1_P 23.9
Rsw1 vminus vsminus_N 1 RESISTANCE={100e6-(100e6*swtch-1u)}
Lom Cp1_P 0 34.5u
C2 Rp3_N C2_N 109.4f
Rm1 Lm1_N Cp1_P 38.7
Rc vsplus_N DUT_Gnd 1u
C1 Rp3_N C1_N 3.14f
Rtipm R1_N vminus 98.85
R1 L1_N R1_N 451.7
R2 L2_N R1_N 2m

.AC DEC 200 200k 20G SWEEP PARAM=swtch LIN 2 0 1

.PARAM swtch 1
```

Measured and Modeled Data Matching

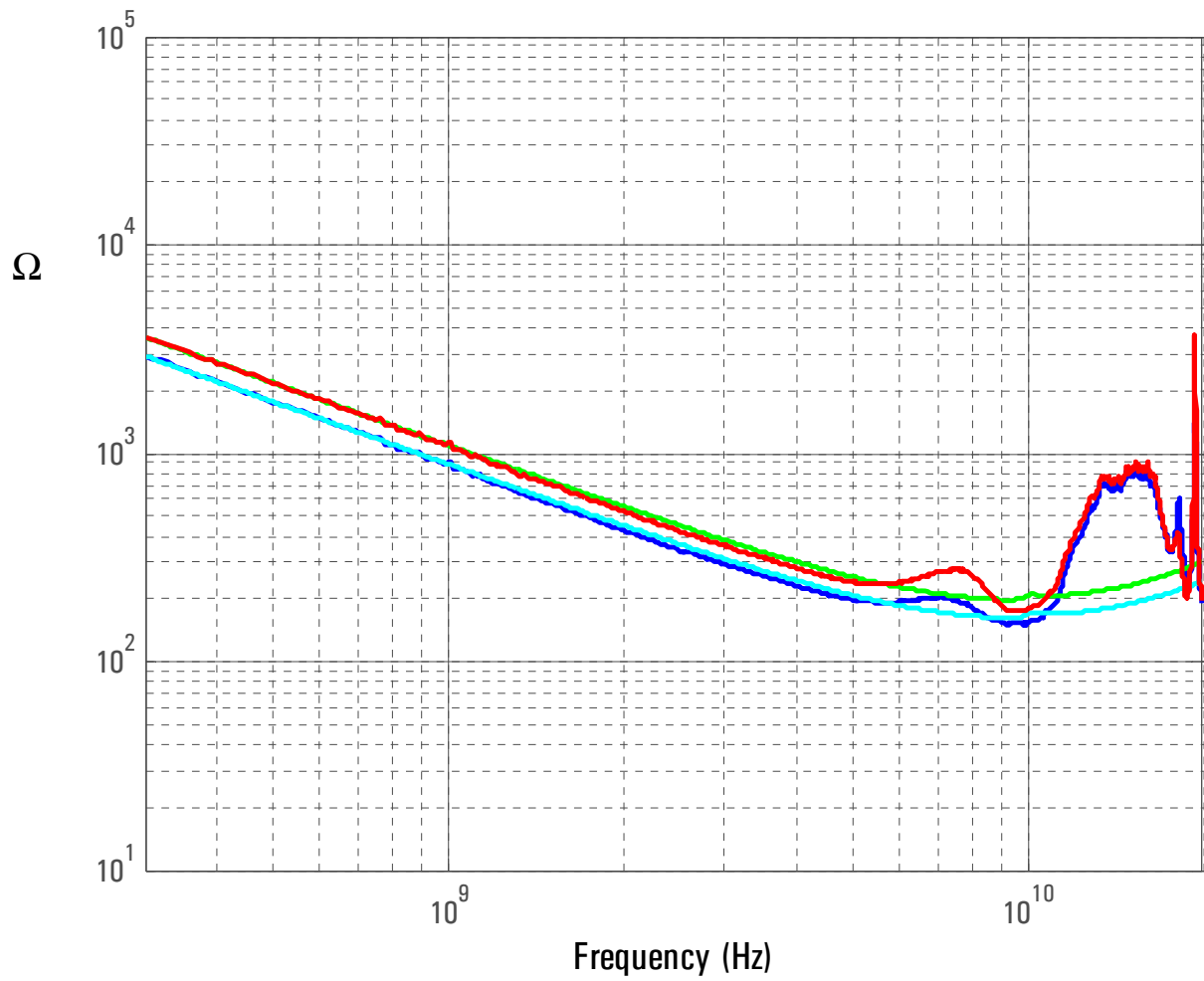

Input Impedance SPICE Model for N2887A/N2888A Probe Heads

Differential SPICE Input Impedance Model

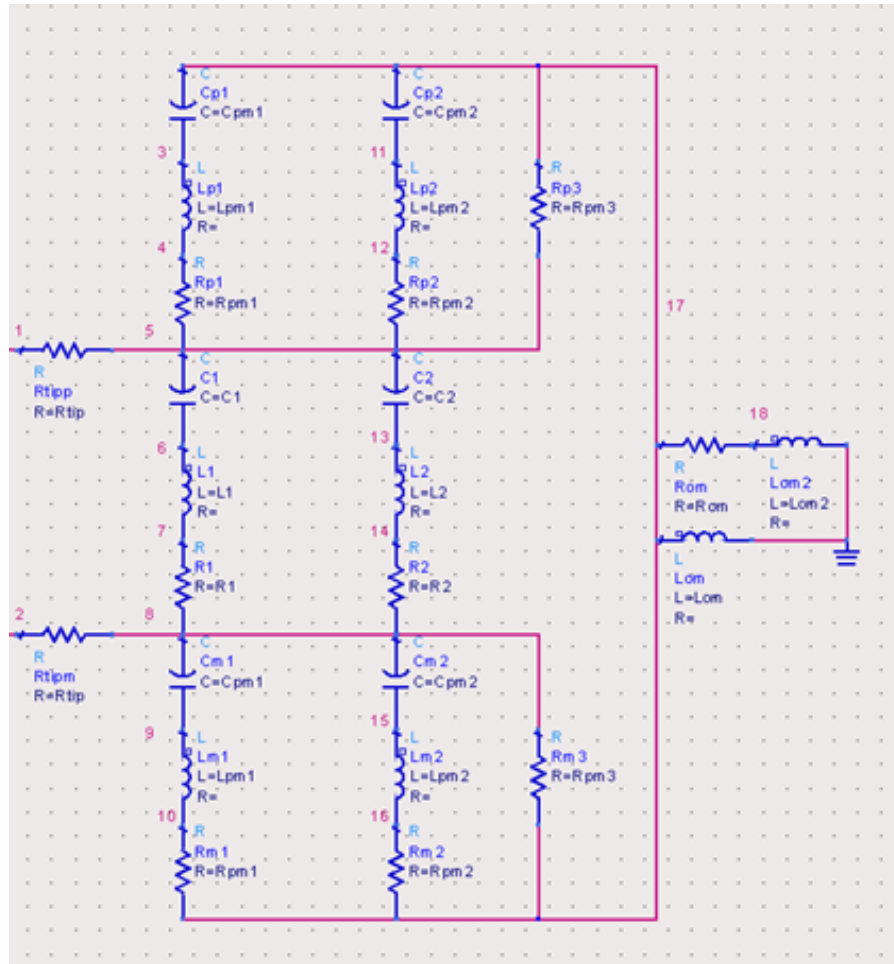

```
.subckt N2887A_Differential 1 2
```

```
rtipp 1 5 1e-12
rtipm 2 8 1e-12
cp1 3 17 .174p
lp1 3 4 1.843n
rp1 4 5 9.309
cm1 8 9 .174p
lm1 9 10 1.843n
rm1 10 17 9.309
c1 5 6 .101p
l1 6 7 2.844n
r1 7 8 14.645
cp2 17 11 .329p
lp2 11 12 .335n
rp2 12 5 18.747
cm2 8 15 .329p
lm2 15 16 .335n
rm2 16 17 18.747
c2 5 13 .00001p
l2 13 14 .505n
```

```

r2 14 8 45.82
rp3 17 5 25k
rm3 8 17 25k
rom 17 18 3.82e-8
lom2 18 0 .501n
lom 17 0 20.5u
.ends

```

Single-ended SPICE Input Impedance Model

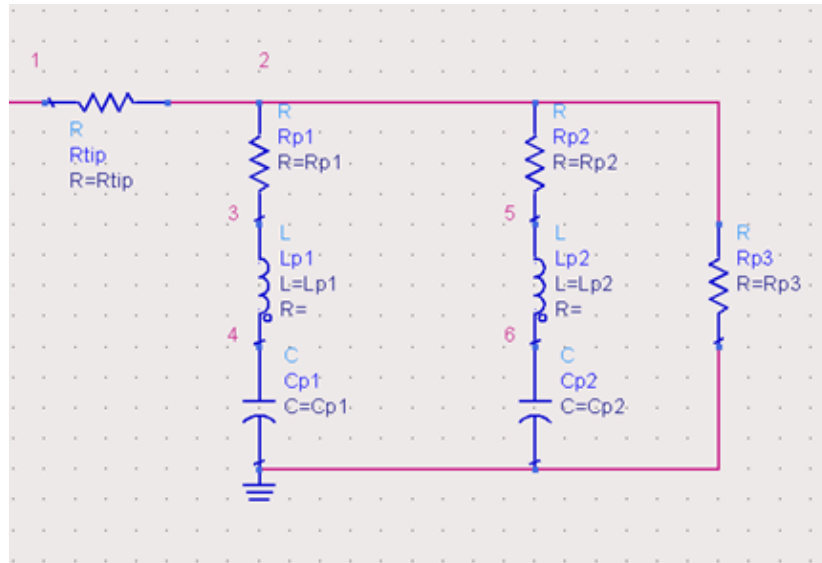

```

.subckt N2887A_SingleEnded 1
rtip 1 2 1e-12
rp1 2 3 12.480
lp1 3 4 1.525n
cp1 4 0 .407p
rp2 2 5 24.445
lp2 5 6 2.285n
cp2 6 0 .140p
rp3 2 0 25k
.ends

```

Spice Models
Input Impedance SPICE Model for N2887A/N2888A Probe Heads

Service

Service

The service section of this manual contains the following information:

- Service Strategy for the probe
- Cleaning the probe
- Returning the probe to Agilent Technologies for service
- Recommended tools and test equipment
- Calibration Testing Procedures
 - To Test Bandwidth
 - To Test Input Resistance
- Performance test record
- Replaceable parts and accessories

Service Strategy for the Probe

This chapter provides service information for the InfiniiMax Probe. The following sections are included in this chapter.

- Service strategy
- Returning to Agilent Technologies for service
- Troubleshooting
- Failure symptoms

The InfiniiMax Probe is a high frequency device with many critical relationships between parts. For example, the frequency response of the amplifier on the hybrid is trimmed to match the output coaxial cable. As a result, to return the probe to optimum performance requires factory repair. If the probe is under warranty, normal warranty services apply.

Warranted specifications are listed below.

Table 4-1

Description	Specification	Further Information
Bandwidth	12 GHz (1169A) 10 GHz (1168A)	
Input Resistance	50 k Ω \pm 2% 25 k Ω \pm 2%	Differential mode resistance Single-ended mode resistance each side to ground

You may perform the tests in the "Calibration and Operational Verification Tests" later in this chapter to ensure these specifications are met.

If the probe is found to be defective we recommend sending it to an authorized service center for all repair and calibration needs. Please see the "To return the probe to Agilent Technologies for service" on page 4-4.

Service
To return the probe to Agilent Technologies for service

To return the probe to Agilent Technologies for service

Follow the following steps before shipping the InfiniiMax Probe back to Agilent Technologies for service.

- 1** Contact your nearest Agilent sales office for information on obtaining an RMA number and return address.
- 2** Write the following information on a tag and attach it to the malfunctioning equipment.

Name and address of owner

Product model number Example 1169A

Product Serial Number Example MYXXXXXXXX

Description of failure or service required

Include probing and browsing tips if you feel the probe is not meeting performance specifications or a yearly calibration is requested.

- 3** Protect the Probe by wrapping in plastic or heavy paper.
- 4** Pack the Probe in the original carrying case or if not available use bubble wrap or packing peanuts.
- 5** Place securely in sealed shipping container and mark container as "FRAGILE".

If any correspondence is required, refer to the product by serial number and model number.

Troubleshooting

- If your probe is under warranty and requires repair, return it to Agilent Technologies. Contact your nearest Agilent Technologies Service Center.
- If the failed probe is not under warranty, you may exchange it for a reconditioned probe. See "To Prepare the Probe for Exchange" in this chapter.

Failure Symptoms

The following symptoms may indicate a problem with the probe or the way it is used. Possible remedies and repair strategies are included.

The most important troubleshooting technique is to try different combinations of equipment so you can isolate the problem to a specific probe.

Probe Calibration Fails

Probe calibration failure with an oscilloscope is usually caused by improper setup. If the calibration will not pass, check the following:

- Check that the probe passes a waveform with the correct amplitude.
- If the probe is powered by the oscilloscope, check that the offset is approximately correct. The probe calibration cannot correct major failures.
- Be sure the oscilloscope passes calibration without the probe.
- Be sure that the probe head that you are using has been in the oscilloscope's Probe Setup dialog box.

Incorrect Pulse Response (flatness)

If the probe's pulse response shows a top that is not flat, check for the following:

- Output of probe must be terminated into a proper 50 Ω termination. If you are using the probe with an Infiniium oscilloscope, this should not be a problem. If you are using the probe with other test gear, insure the probe is terminated into a low reflectivity 50 Ω load ($\sim \pm 2\%$).
- If the coax or coaxes of the probe head in use has excessive damage, then reflections may be seen within ~ 1 ns of the input edge. If you suspect a probe head, swap it with another probe head and see if the non-flatness problem is fixed.
- If one of the components in the tip has been damaged, there may be a frequency gain non-flatness at around 40 MHz. If you suspect a probe head, swap it with another probe head and see if the non-flatness problem is fixed.

Incorrect Input Resistance

The input resistance is determined by the probe head in use. If the probe head is defective, damaged, or has been exposed to excessive voltage, the input resistor may be damaged. If this is the case, the probe head is no longer useful. A new probe head will need to be obtained either through purchase or warranty return.

Incorrect Offset

Assuming the probe head in use is properly functioning, incorrect offset may be caused by defect or damage to the probe amplifier or by lack of probe calibration with the oscilloscope.

Calibration Testing Procedures

These tests can be performed to ensure the Probe meets specifications.

**Service
To Test Bandwidth**

To Test Bandwidth

This test ensures that the Probe meets its specified bandwidth.

1169A >12 GHz
1168A > 10 GHz

Table 4-2

Equipment/Tool	Critical Specification	Model Number
Vector Network Analyzer (VNA)	13 GHz sweep range full 2 port cal Option 1D5	Agilent 8720ES
Calibration Standards	No Substitute	Agilent 85052D
External Power Supply	No Substitute	Agilent 1143A
AutoProbe Interface Adapter	No Substitute	Agilent N1022A
Outside thread 3.5 mm (male) to 3.5 mm (female) adapter	No Substitute	Agilent 5062-1247
Cable (2)	3.5 mil; SMA; High Quality	Agilent 8120-4948
Cable	1.5 mil Probe Power Extension No Substitute	Agilent 01143-61602
PV/DS Test Board	No Substitute (In E2655B Kit)	Agilent E2655-66503

Using the 8720ES VNA successfully

Remember these simple guidelines when working with the 8720ES VNA to get accurate stable measurements.

- 1 Sometimes it may take a few seconds for the waveforms to settle completely. Please allow time for waveforms to settle before continuing.
- 2 Make sure all connections are tight and secure. If needed, use a vise to hold the cables and test board stable while making measurements.
- 3 Be careful not to cross thread or force any connectors. This could be a very costly error to correct.

Initial Setup

- 1 Turn on the 8720ES VNA and let warm up for 20 minutes.
- 2 Press the green "Preset" key on the 8720ES VNA.
- 3 Use the 8720ES VNA's default power setting of 0 dBm. You can locate this feature by pressing the "Power" key on the front panel.
- 4 Set the 8720ES VNA's averaging to 4. You can find this selection menu by pressing the "AVG" key. Then select the "Averaging Factor" screen key to adjust the averaging.
- 5 Press the "Sweep Setup" key on the 8720ES VNA. Then press the "sweep type menu" screen key. Select the "log freq" screen key.
- 6 Connect the probe under test to the Auto Probe Adapter and power the probe using the 1143A power supply. Install the outside thread adapter to the Auto Probe Adapter.

Figure 4-1

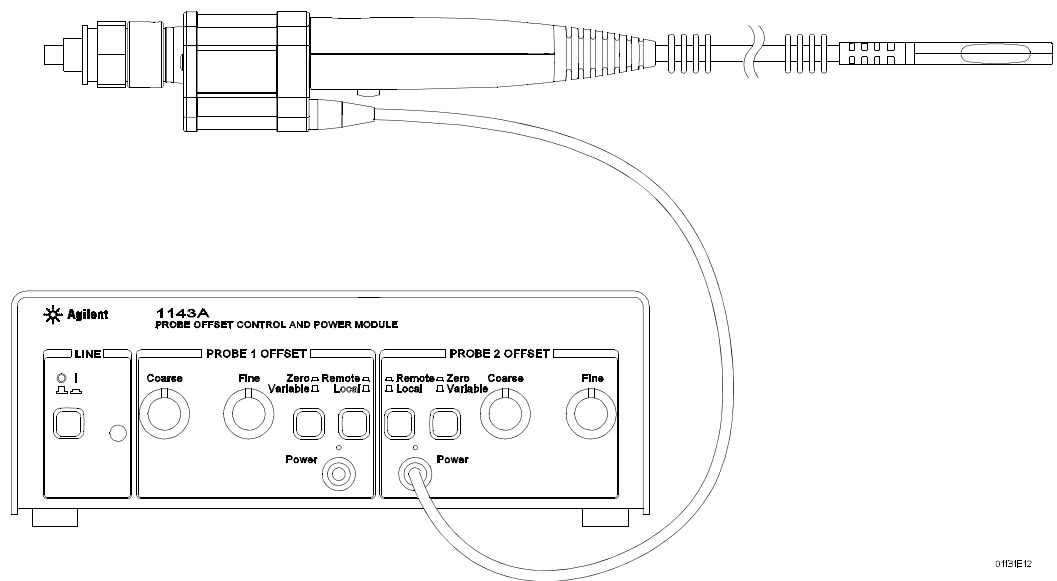

01B/E12

Calibrating a Reference Plane

To get a reliable measurement from the 8720ES VNA we must calibrate a reference plane so that the 8720ES VNA knows where the probe under test is located along the transmission line.

Service To Test Bandwidth

- 1 Press the "Cal" key on the 8720ES VNA.

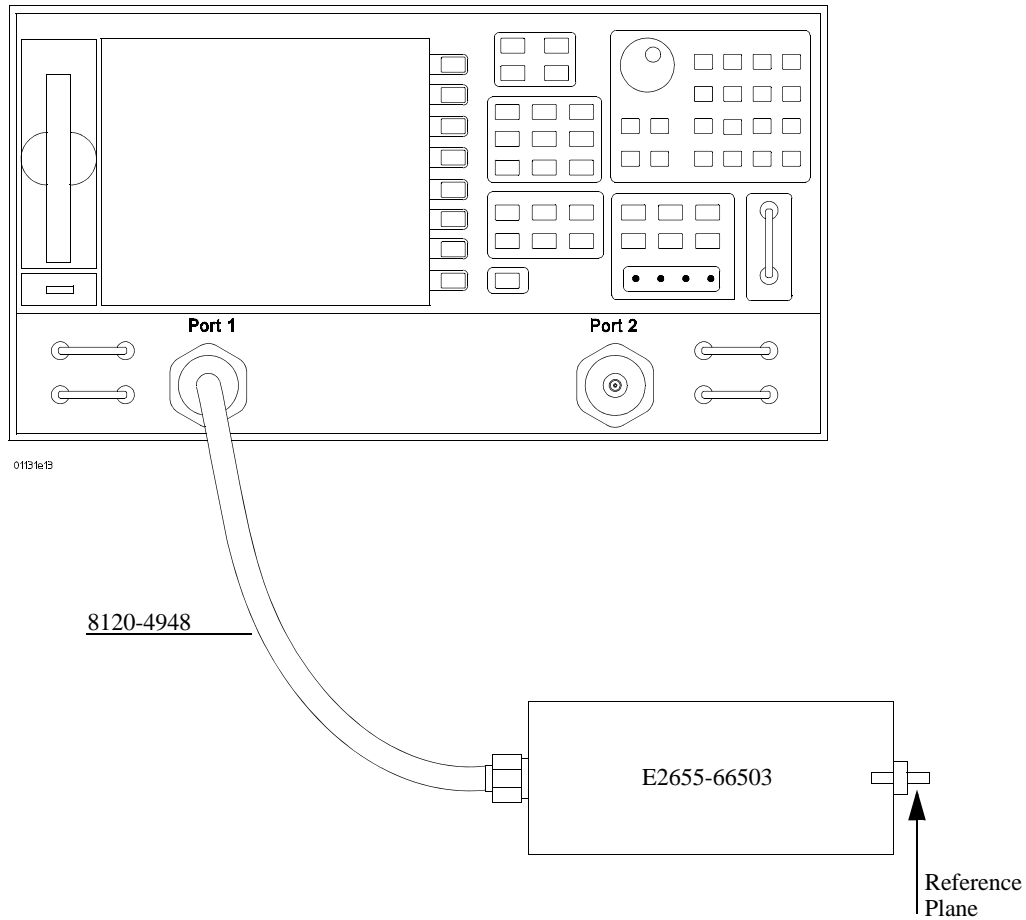

- 2 Then Press the "cal menu" screen key.
- 3 Finally, press the "full 2 port" screen key.
- 4 Connect one of the high quality SMA cables to port one and to the pincher side of PV/DS test board.
- 5 The calibration reference plane is at the other end of PV/DS test board.

Figure 4-2

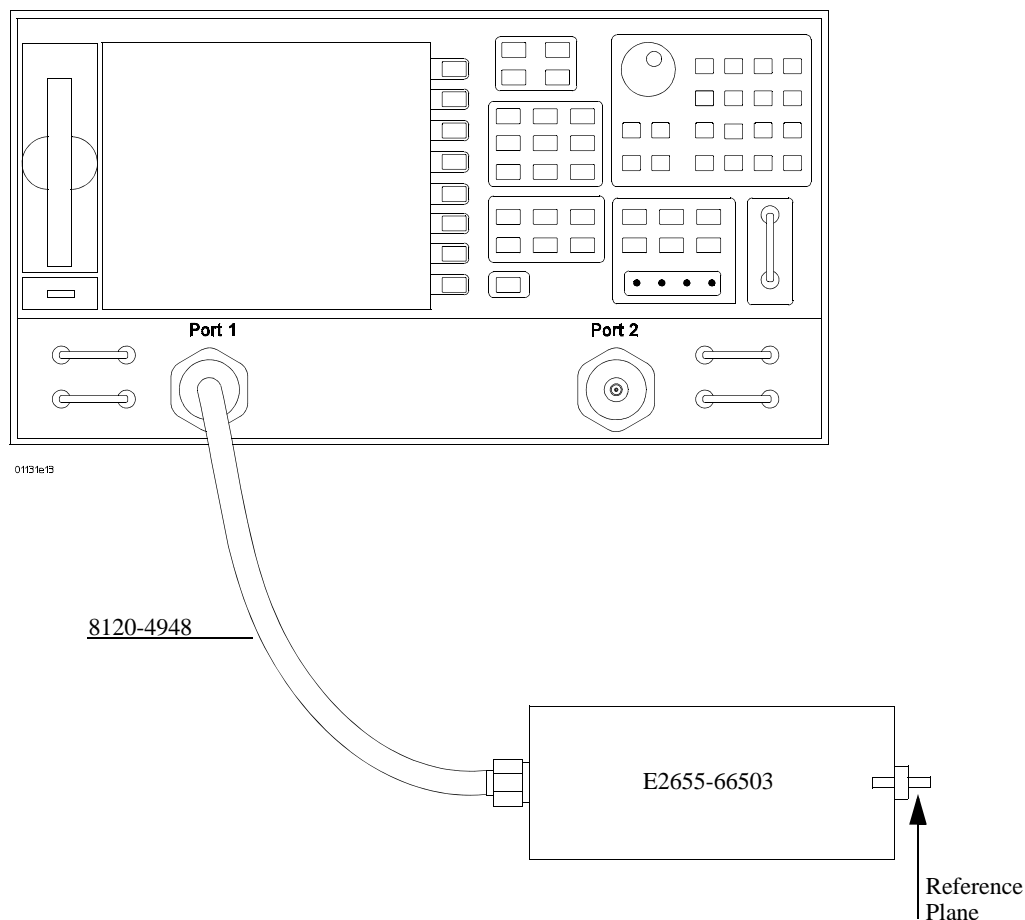

- 6 Perform Calibration for the port one side of the Reference plane.
 - Press the "reflection" screen key
 - Connect open end of 85052D to the non-pincher side of the PV/DS test board.
 - Select the "open" screen key under the "Forward" group.
 - The 8720ES VAN will beep when done.
 - Connect short end of 85052D to the non-pincher side of the PV/DS test board.
 - Select "short" screen key under the "Forward" group.
 - The 8720ES VAN will beep when done.
 - Connect load end of 85052D to the non-pincher side of the PV/DS test board.
 - Select the "loads" screen key under the "Forward" group.
 - Press "broadband" screen key selection.
 - The 8720ES VAN will beep when done.
 - Press the "done loads" screen key.
 - You have just calibrated one side of the reference plane.
- 7 Connect the other high quality SMA cable to port two of the 8720ES VNA.

**Service
To Test Bandwidth**

Figure 4-3

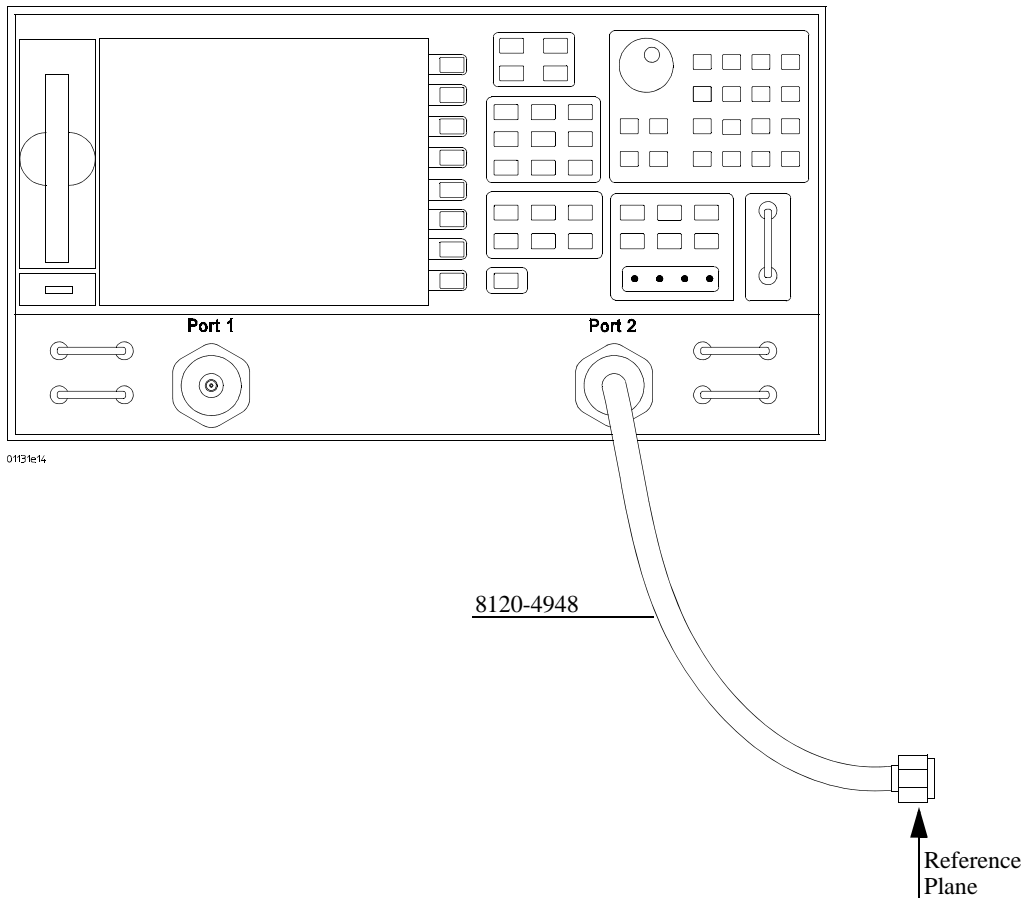

- 8** Get the opposite sex of the 85052D calibration standards for the next step.
- 9** Perform Calibration for the port two side of the Reference plane.
 - Press the "reflection" screen key.
 - Connect open end of 85052D to the available end of the port two SMA cable.
 - Select "open" screen key under the "Reverse" group.
 - The 8720ES VNA will beep when done.
 - Connect short end of 85052D to the available end of the port two SMA cable.
 - Select "short" screen key the "Reverse" group.
 - The 8720ES VNA will beep when done.
 - Connect load end of 85052D to the available end of the port two SMA cable.
 - Select the "loads" screen key the "Reverse" group.
 - Press "broadband" screen key selection.
 - The 8720ES VNA will beep when done.
 - Press the "done loads" screen key.
 - You have just calibrated the other side of the reference plane.
- 10** Press "standards done" key.
- 11** Connect port two SMA cable to the non-pincher side of PV/DS test board.

Figure 4-4

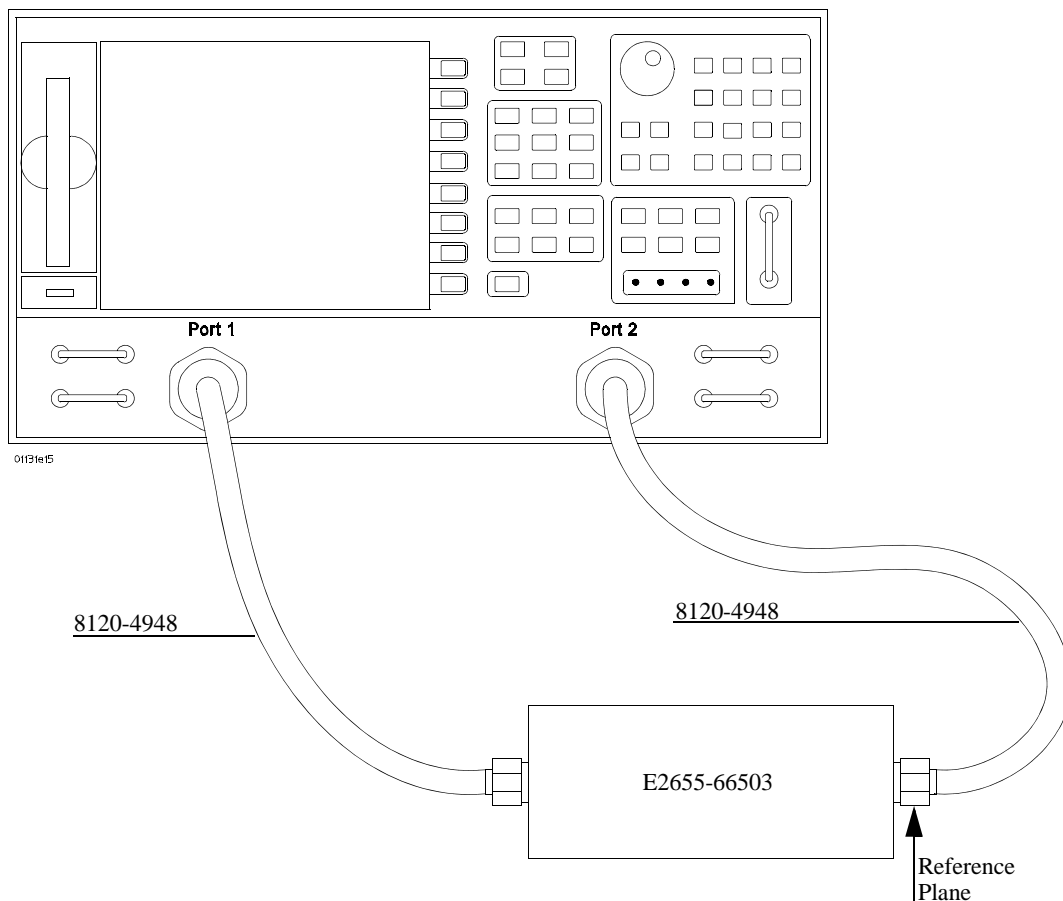

- 12 Press the "transmission" screen key.
- 13 Press the "do both fwd and reverse" screen key.
- 14 The 8720ES VNA will beep **four** times when done.
- 15 Press the "isolation" screen key.
- 16 Press the "omit isolation" screen key.
- 17 Press "done 2 port cal" screen key.
- 18 Set the 8720ES VNA's averaging to off.
- 19 Save the reference plane cal by pressing the "save recall" key then the "save state" key.
- 20 You may change name if you wish.
- 21 Press the "scale reference" key. Then
 - Set for 1 dB per division.
 - Set reference position for 7 divisions.
 - Set reference value for 0 dB
- 22 Press the "measure" key.
- 23 Press the "s21" screen key.
- 24 Ensure s21 response on screen is flat (about ± 0.1 dB) out to 13 GHz.

Service To Test Bandwidth

Measuring Vin Response

- 1 Position the probe conveniently to allow the probe tip to be normal to the PV/DS board. See Figure 4-5.
- 2 Spread the probe tip wires slightly so that the tips are a little bit wider than the gap between the signal trace and the ground on PV/DS board
- 3 To best simulate the conditions that are present when the probe is in actual use, inset only the tips of the wires under the pincher. Do not inset the wires completely under the pincher such that the contact points are right next to the tip of the PC board. The best way to accomplish this is to insert the wires under the pincher with the probe head at a 45 degree angle with respect to the PV/DS board, then apply upward pressure to the clip to hold the tip wires firmly. Gently pull the probe head up to the 90 degree position. This will actually form the wires into an "L" shape.

Place the "+" side on center conductor and "-" side to ground.

Press the "Sweep Setup" key on the 8720ES VNA. Then press the "trigger menu" screen key.

Select the "continuous" screen key.

Figure 4-5

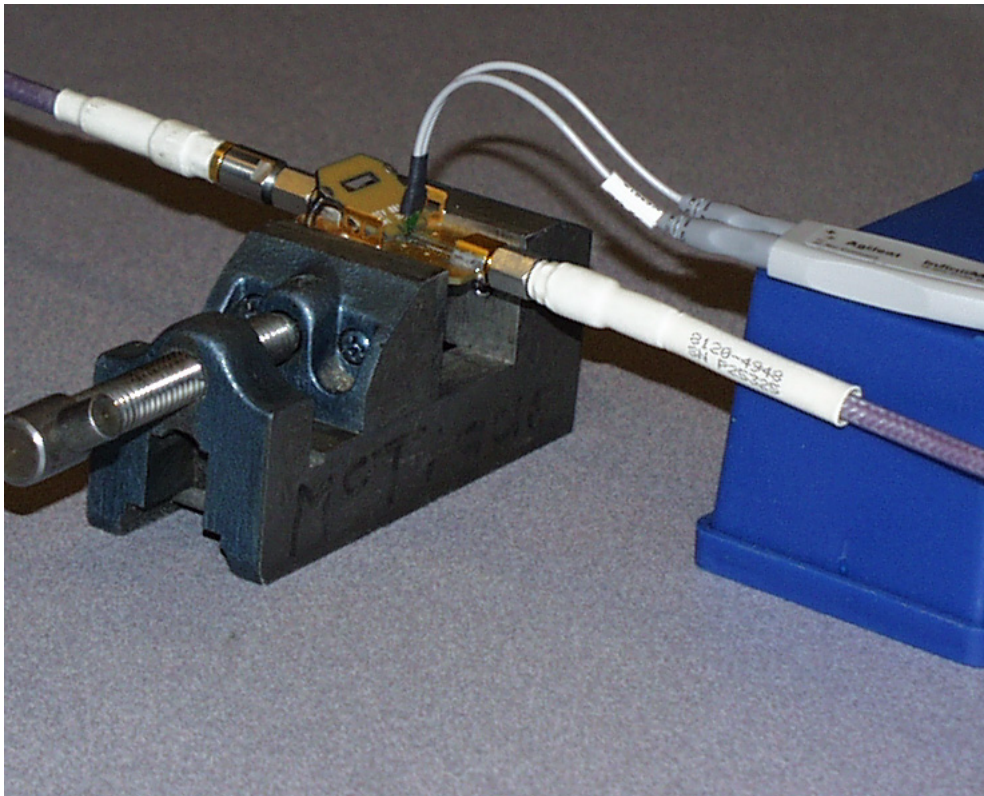

- 4 You should now have the Vin waveform on screen. It should look similar to Figure 4-6.

Figure 4-6

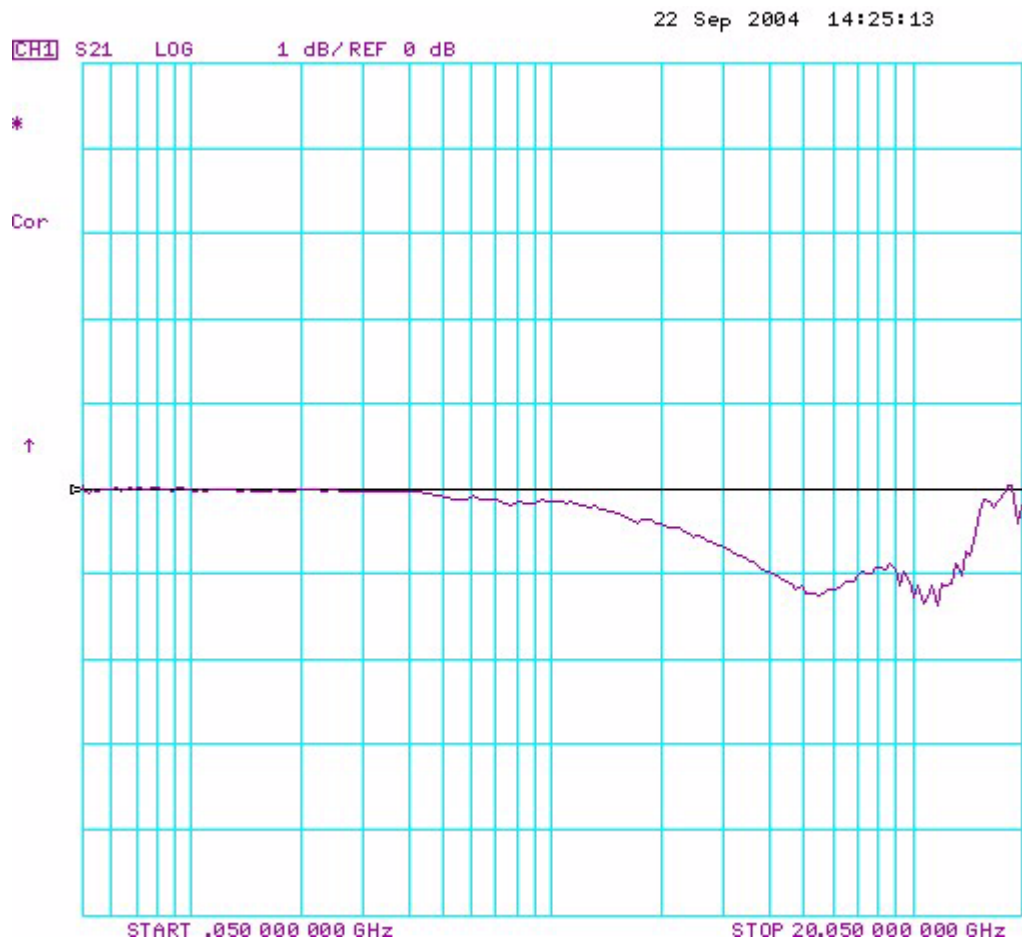

- 5 Select "display key" then "data->memory" screen key.
- 6 You have now saved Vin waveform into the 8720ES VNA's memory for future use.

**Service
To Test Bandwidth**

Measuring Vout Response

- 1 Disconnect the port 2 cable from PV/DS test board and attach to probe output on the AutoProbe Adapter.
- 2 Connect the 85052D cal standard load to PV/DS test board (non-pincher side). See Figure 4-7.
- 3 Check that the tip connection is still proper. See "Measuring Vin Response" on page 4-14

Figure 4-7

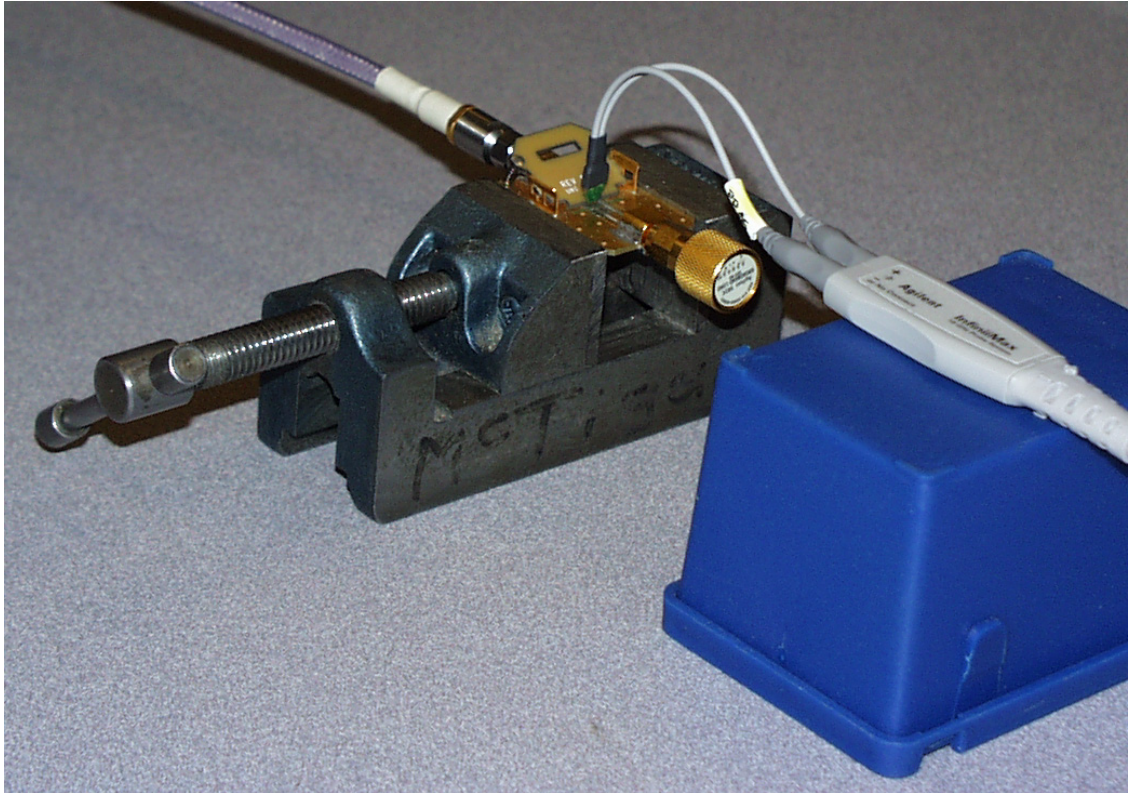

- 4 Press "scale reference" key on the 8720ES VNA.
- 5 Set reference value to -10.8 dB.
- 6 The display on screen is Vout. It should look similar to Figure 4-8.

Figure 4-8

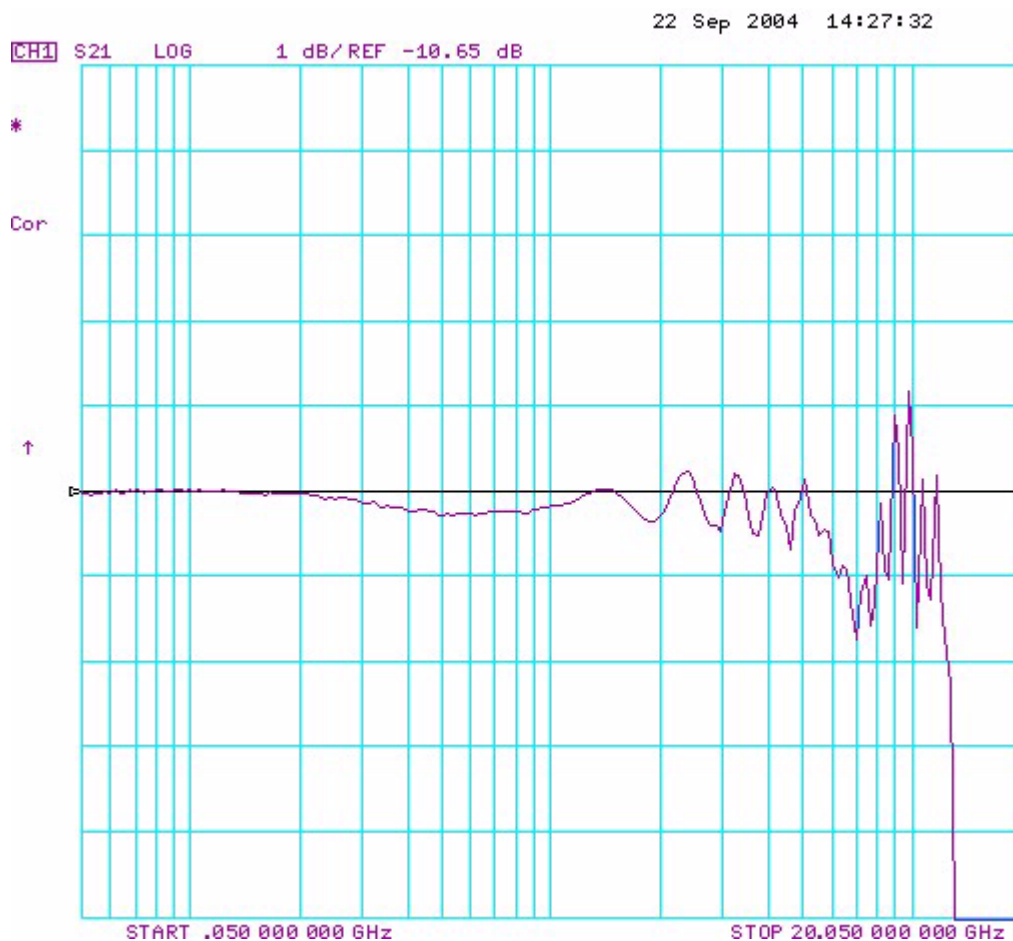

Displaying Vout/Vin Response on 8720ES VNA Screen

- 1 Press the "Display" Key.
- 2 Then select the "Data/Memory" Screen Key. The display should look similar to Figure 4-9. You may need to adjust the "Reference Value", located under the "Scale Ref" key, slightly to position the waveform at center screen at 100 MHz.
- 3 Press marker key and position the marker to the first point that the signal is -2.6 dB below center screen. Minus 2.6 dB is used rather than -3 dB because the loss caused by the PV/DS board makes a slightly optimistic measurement.
- 4 Read marker frequency measurement and record it in the test record located later in this chapter.
- 5 The bandwidth test passes if the frequency measurement is greater than the probe's bandwidth limit. Example: > 12 GHz (1169A) or 10 GHz (1168A).

Service
To Test Bandwidth

Figure 4-9

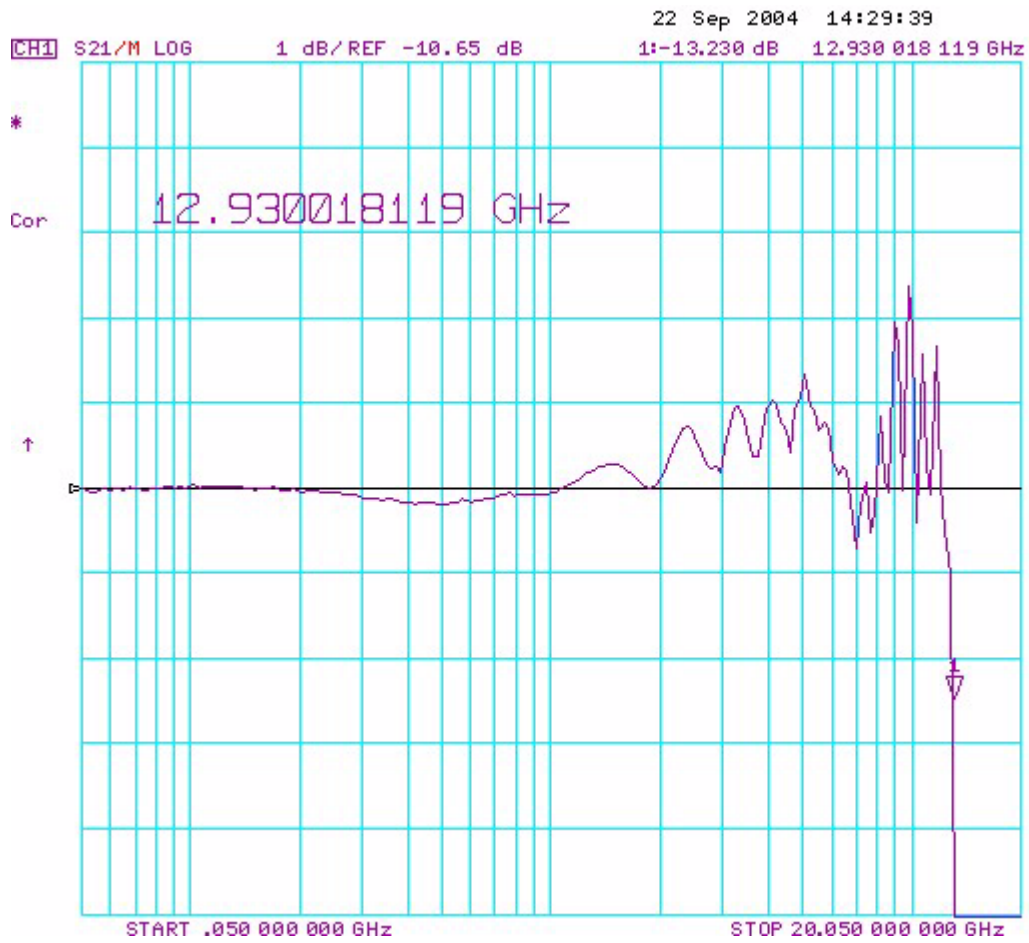

To Test Input Resistance

This test ensures that the Probe meets its specified input resistance.

Differential Mode	50 k Ω \pm 2%
Single-ended Mode	25 k Ω \pm 2%

Table 4-10

Equipment/Tool	Critical Specification	Model Number
Oscilloscope	No substitute. Requires precision BNC connectors	DSO80000 Series Infiniium Oscilloscope
Digital Multimeter	2 wire resistance accuracy better than \pm 0.01%	34401A
Adapter	BNC (f) to SMA(m) (In E2655B Kit)	E2655-83201
PV/DS Test Board	No Substitute (In E2655B Kit)	E2655-66503

Initial Setup

- 1** Power on the Infiniium oscilloscope and 34401A DMM.
- 2** Connect the probe under test to Channel 1 of the Infiniium oscilloscope.
- 3** Select the 2-wire Ohm display on the 34401A DMM.

Service
To Test Input Resistance

Differential Test

- 1 Using the PV/DS test board, connect the "+" and "-" probe tips to the 34401A DMM.

Apply upward pressure to the clip to insure proper electrical connection.

Figure 4-11

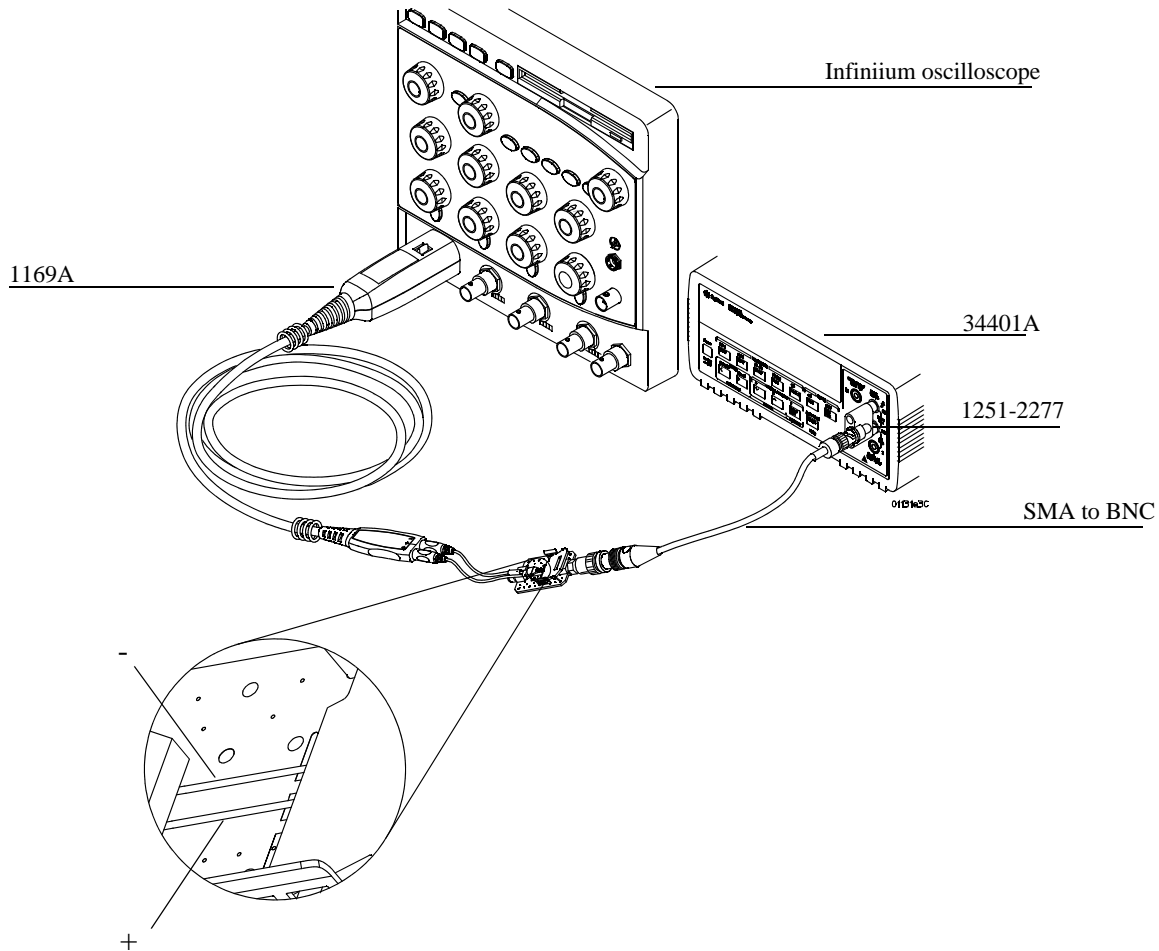

- 2 Read the 34401A display for the Input Resistance.
- 3 Record the result in the performance test record later in this chapter. To pass this test the result should be between 49,000 Ω and 51,000 Ω .

Single-ended Test

- 1 Using the PV/DS test board, connect the "+" probe trip to the 34401A DMM.

Apply upward pressure to the clip to insure proper electrical connection.

- 2 Connect the amp body ground to the PV/DS test board ground.

Figure 4-12

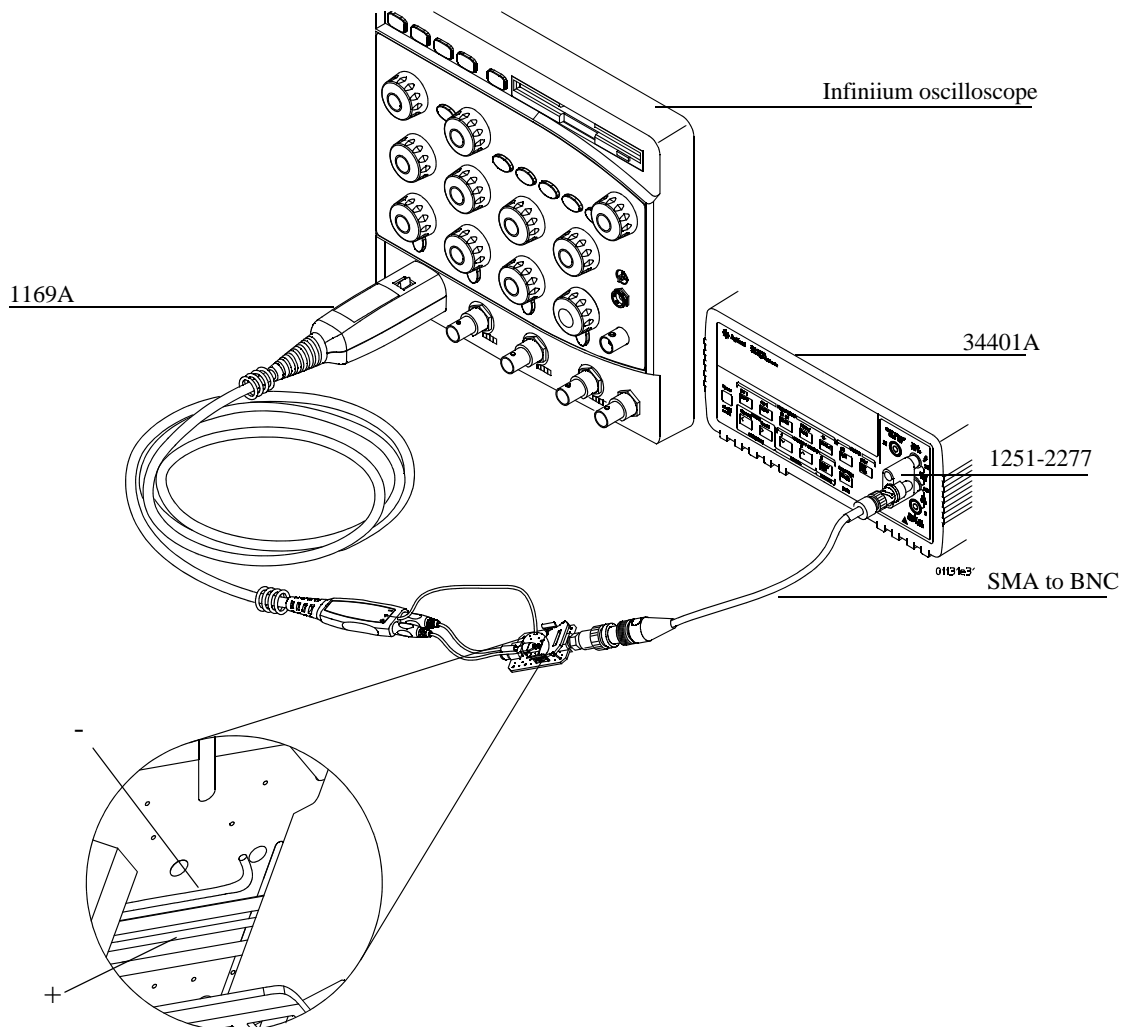

- 3 Read the 34401A display for the Input Resistance.
- 4 Record the result in the performance test record later in this chapter. To pass this test the result should be between 24,500 Ω and 25,500 Ω .

Service
To Test Input Resistance

- 5 Using the PV/DS test board, connect the "-" probe trip to the 34401A DMM.

Apply upward pressure to the clip to insure proper electrical connection.

- 6 Connect the amp body to ground on the PV/DS test board.

Figure 4-13

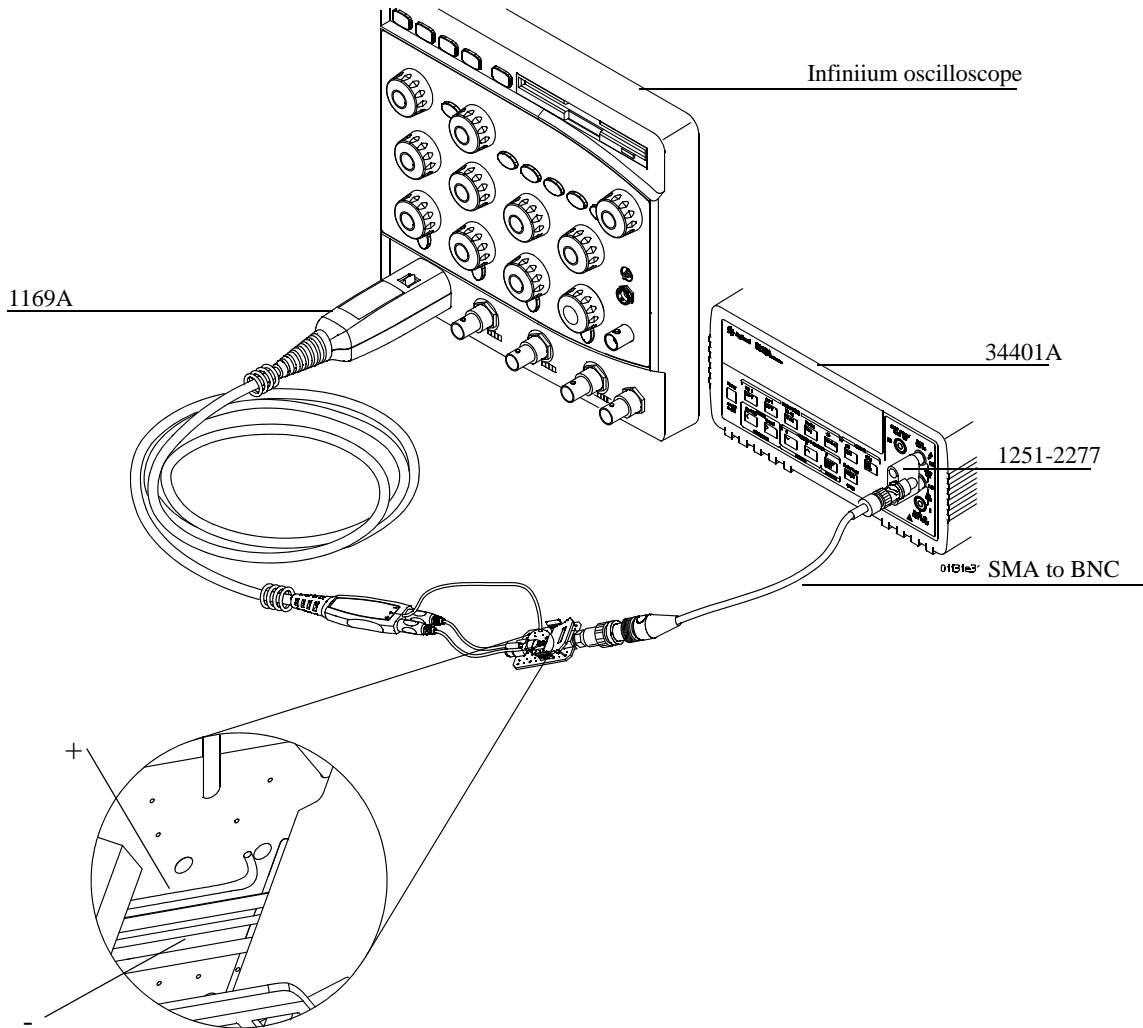

- 7 Read the 34401A display for the Input Resistance.
- 8 Record the result in the performance test record later in this chapter. To pass this test the result should be between 24,500 Ω and 25,500 Ω .

A recommended grounding solution is to use the probe body ground.

Performance Test Record

Test Name	Results	
Bandwidth	> 12 GHz (1169A) > 10 GHz (1168A) Result _____ GHz	Pass/Fail
Input Resistance	Differential Mode Limits: 49,000 Ω to 51,000 Ω ± _____ kΩ	Pass/Fail
	Single-ended Mode Limits: 24,500 Ω to 25,500 Ω + _____ kΩ - _____ kΩ	Pass/Fail

Index

A

accessories
 additional 1-16
 using 1-78

B

bandwidth
 specification 1-19
bandwidth test 4-8

C

calibration
 failure 4-6
 probe with oscilloscope 1-35
calibration procedure 4-7
cleaning the probe 1-35

D

differential connectivity kit 1-11
dimensions 1-24
 probe amp 1-31
 resistor 1-27

E

E2669A differential connectivity kit 1-11

F

failure symptoms 4-6

G

general characteristics 1-24

O

operating environment 1-24

P

packing for return 4-4
power requirements 1-24
probe
 cleaning 1-35
 dimensions 1-31
 handling 1-35
 using 1-35
 using accessories 1-78

R

repair 4-4
replaceable parts 1-16
resistance testing 4-19
resistor
 dimensions 1-27, 1-36
resistors
 replacing 1-40
returning probe to Agilent Technologies 4-4

S

service
 strategy 4-3
solder-in tips
 procedure 1-40
specifications 1-19
 warranted 4-3

T

test
 bandwidth 4-8
testing
 input resistance 4-19
 trimming the resistors 1-27
troubleshooting 4-5

W

weight 1-24

